

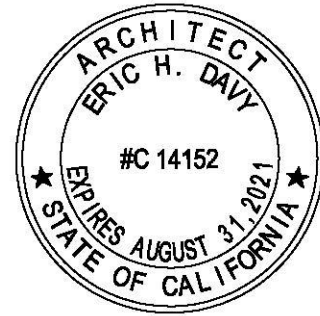

Addendum 02 | AX1

District: San Bernardino City Unified School District
Project: San Bernardino High School – Bldg. M “Maker Space”
DSA A#: 04-118980
Bid #: F21-04

July 16, 2021



Davy Architecture
1053 10th Ave.,
San Diego, CA 92101

PART 1 - General

- 1.1 This Addendum is generally separated into sections for convenience; however, all contractors, subcontractors, material suppliers and other involved parties shall be responsible for reading the entire Addendum.
- 1.2 The following revisions and/or clarifications shall be made to the Bidding Requirements and Contract Documents. Revise and amend the Documents for the above-named project in accordance with this Addendum. The bid shall reflect these addendum changes.
- 1.3 Contractor’s Prequalification List as of 07/15/21, is available for bidder reference at District’s website: <https://sbcusdfacilities.com/transforming-schools/bid-opportunities/>
- 1.3.1 Bid Cover Sheet
- 1.4 Additions and clarifications:
 - A. The following additions and clarifications are issued to all bidders as information for use in preparing bids:
 1. Response to Southern Counties Quality Masonry RFI 1. – Appendix D is not used.
 2. Response to Southern Counties Quality Masonry RFI 2. – Substitutions may be proposed via a substitution request form for the substitution of Orco Block or Angelus Block. Contractor to demonstrate specification requirements are equal in the substitution request form.
 3. Response to Southern Counties Quality Masonry RFI 3. – Per Exterior Elevation 3/A-502, CMU below and above display case are Style Regalstone / Color Ruby.
 4. Response to Inland Building Construction Companies, Inc. RFI 1. – Appendix D is not used. For Colors, Textures, and Patterns Refer to sheets A-501, A-502, & A-503 for exterior exposed masonry units and refer to sheet A-701, A-701.1, A-702, A-703 & A-703.1 for interior face exposed masonry unit walls.
 5. Response to Inland Building Construction Companies, Inc. RFI 2. – Per E-101 Keynote 9, the (3) 3” conduits are also new.

6. Response to Oakview Constructors, Inc. RFI 1. – Refer to added spec section 12 24 13 for Roller Shades.
7. Response to Oakview Constructors, Inc. RFI 2. –
 - A. See attached product spec sheet #Procolor 652U and #Chief FCA V1U for wall hung Display and support bracket.
 - B. See attached product spec sheet Diamond Lifegear #HPBPX for Pegboard w/ Multi-pronged tool holder and accessories kit.
 - C. See attached product spec sheet Virco #TE30608DADJ for 34" high ADA accessible adjustable height table.
8. Response to Oakview Constructors, Inc. RFI 3. – See attached product spec sheet School Outfitters #GHE-A2M48 for marker boards and product spec sheet School Outfitters #GHE-12UV48-W and #GHE-12UV46-W for Tack boards.
9. Response to Fortran Electric. – Refer to Addendum #1 for estimated project budget.
10. Response to Avidex Industries, LLC. RFI 1. –
 - A. Refer to the Assistive Listening Devices Quantities tables on sheet G-005 for the maximum occupant load and number of devices required at each building.
 - B. Per G-005 Assistive Listening Devices are required at M1-4 and M3-1 Flex Space.
 - C. Spec section 274116 does not apply to M3-1. District to confirm no projector or Display Panel will be required at this space.
11. Response to Avidex Industries, LLC. RFI 2-
 - A. No separate spec section to be provided. Spec section 274116 is provided for common work as required for the installation of audio systems. Make and model of systems to be provided as called out in the plans.
 - B. The GC is responsible for providing and the installation of a complete operational AV system as intended in the drawings.
 - C. The GC is responsible for providing and installing the AV Box Model Number: PWB-FR-450 see attached product spec sheet.
 - D. Refer to sheet A-702 for the location of the Flat Display Panel Model number: Procolor 652U and support bracket model #Chief FCA V1U.
12. Response to Cal-City Construction Inc. –
 - A. The District would like all Converse's recommendations to be included in the bidder's price and scope of work.
 - B. See section 5.5 Table 1 and Figure 2 of report for the area and depth of the lead impacted soil in the vicinity of boring B5.
 - C. Active sub-slab ventilation, passive sub-slab ventilation, geomembranes and / or sealants are examples of mitigation measures to limit vapor intrusion of PCE.
13. Response to Golden State Roofing – No exception taken to Substitution request.
14. See attached exhibit for additional marker boards and tack boards to be added to building M3.



PART 2 - Project Manual

No Revisions to Project Manual

PART 3 - Drawings:

No Revisions to Drawings.

PART 4 - Enclosures:

- 4.1 Specification section 12 24 13 Roller Shades
- 4.2 Product spec sheet Procolor 652U and Chief FCA V1U for wall hung Display and support bracket.
- 4.3 Product spec sheet Diamond Lifegear #HPBPX for Pegboard w/ Multi-pronged tool holder and accessories kit.
- 4.4 Product spec sheet Virco #TE30608DADJ for 34" high ADA accessible adjustable height table
- 4.5 Product spec sheet School Outfitters #GHE-A2M48 for marker boards and product spec sheet School Outfitters #GHE-12UV48-W and #GHE-12UV46-W for Tack boards.
- 4.6 Product spec sheet #PWB-FR-450 for AV Box
- 4.7 Supplemental Asbestos Survey & Summary of Survey Results Letter
- 4.8 Summary of Ceramics Tile Grout Sampling
- 4.9 Abatement Specifications – PCBs, Fluorescent Light Tubes, Smoke Detectors and Aerosols
- 4.10 Abatement Specifications – Asbestos
- 4.11 Abatement Specifications – Lead
- 4.12 Golden State Roofing – Substitution Request
- 4.13 Building M3 Assembly Hall Exhibit for the additional marker boards and tack boards to be included.

End of Document

Bid Cover Sheet

BID NO.: F21-04 **DSA APP #:** 04-118980 **BID DUE:** THURSDAY, JULY 22, 2021 @ 2:00PM

PROJECT NAME: Bid No. F21-04 SBHS – BLDG M “MAKER SPACE”

PROJECT LOCATION: 1850 N. E St., San Bernardino, CA 92405

THE WORK UNDER THIS BID IS A PROJECT OF:
FACILITIES PLANNING AND DEVELOPMENT DEPARTMENT

BID PACKAGE SUBMITTAL FROM:

BIDDER/CONTRACTOR: _____

BIDDER CONTACT: _____

BIDDER ADDRESS: _____

BIDDER TELEPHONE: _____

BIDDER EMAIL: _____

CONTENTS MUST INCLUDE: (Please Check Each Box)

Attachments:

- | | |
|--|--|
| <input type="checkbox"/> #1 - Bid Form | <input type="checkbox"/> #10 - Contractor’s Certificate Regarding Workers’ Compensation Form |
| <input type="checkbox"/> #2 - Request for Substitution | <input type="checkbox"/> #11 - Acknowledgement of Bidding Practices Regarding Indemnity Form |
| <input type="checkbox"/> #3 - Non-Collusion Declaration | <input type="checkbox"/> #12 - Local Business Outreach Program (LBOP) Form |
| <input type="checkbox"/> #4 - Site Visit Certification | <input type="checkbox"/> #13 - COVID-19 Safety Plan |
| <input type="checkbox"/> #5 - Certification of Compliance with DVBE Policy | |
| <input type="checkbox"/> #6 - Designation of Subcontractors | |
| <input type="checkbox"/> #7 - Bid Bond Form | |
| <input type="checkbox"/> #8 –Bid Guarantee Form* | |
| <input type="checkbox"/> #9 - Bidder References & Responsibility Information | |

SUBMIT BID TO: **BID BOX in the Lobby of the**
SAN BERNARDINO CITY UNIFIED SCHOOL DISTRICT
Board of Education Building
777 NORTH “F” STREET
SAN BERNARDINO, CA 92410

NOTE: This sheet must be completed and affixed to the outside of the bid envelope.

SECTION 12 24 13
ROLLER WINDOW SHADES

PART 1 - GENERAL

1.1 SUMMARY

- A. Section Includes:
 - 1. Motor-operated roller shades with single rollers.

1.2 ACTION SUBMITTALS

- A. Product Data: For each type of product.
- B. Shop Drawings: Show fabrication and installation details for roller shades, including shadeband materials, their orientation to rollers, and their seam and batten locations.
 - 1. Motor-Operated Shades: Include details of installation and diagrams for power, signal, and control wiring.
- C. Samples: For each exposed product and for each color and texture specified.

1.3 INFORMATIONAL SUBMITTALS

- A. Product certificates.
- B. Product test reports.

1.4 CLOSEOUT SUBMITTALS

- A. Operation and maintenance data.

1.5 QUALITY ASSURANCE

- A. Installer Qualifications: Fabricator of products.

PART 2 - PRODUCTS

2.1 MANUFACTURERS

- A. Source Limitations: Obtain roller shades from single source from single manufacturer.

2.2 MOTOR-OPERATED, SINGLE-ROLLER SHADES

- A. Motorized Operating System: Provide factory-assembled, shade-operator system of size and capacity and with features, characteristics, and accessories suitable for conditions indicated. Coordinate operator wiring requirements and electrical characteristics with building electrical system.
 - 1. Electrical Components: Listed and labeled as defined in NFPA 70, by a qualified testing agency, and marked for intended location and application.
 - 2. Electric Motor: Manufacturer's standard tubular, enclosed in roller.
 - a. Electrical Characteristics: as indicated in drawings.
 - b. Maximum Total Shade Width: As indicated in drawings, for full length of window.
 - c. Maximum Shade Drop: As indicated in drawings, drop 2” below sill, unless noted otherwise.
 - d. Maximum Weight Capacity: As required to operate roller shades indicated, General Contractor to coordinate with Vendor prior to installation of work..
 - 3. Remote Control: Individual wall-switch control station where indicated in the drawings.
 - 4. Crank-Operator Override: Crank and gearbox operate shades in event of power outage or motor failure.
 - 5. Limit Switches: Adjustable switches interlocked with motor controls and set to stop shades automatically at fully raised and fully lowered positions.
- B. Rollers: Corrosion-resistant steel or extruded-aluminum tubes of diameters and wall thicknesses required to accommodate operating mechanisms and weights and widths of shadebands indicated without deflection. Provide with permanently lubricated drive-end assemblies and idle-end assemblies designed to facilitate removal of shadebands for service.
 - 1. Roller Drive-End Location: Right side of interior face of shade.
 - 2. Direction of Shadeband Roll: Regular, from back (exterior face) of roller.
- C. Mounting Hardware: Brackets or endcaps, corrosion resistant and compatible with roller assembly, operating mechanism, installation accessories, and mounting location and conditions indicated.
- D. Roller-Coupling Assemblies: Coordinated with operating mechanism and designed to join up to three inline rollers that are operated by one roller drive-end assembly.
- E. Shadebands:
 - 1. Shadeband Material: Light-filtering fabric
 - 2. Shadeband Bottom (Hem) Bar: Steel or extruded aluminum.

- a. Type: Exposed with endcaps and integral light seal at bottom where it meets the sill
- b. Color and Finish: As selected by Architect from manufacturer's full range.

F. Installation Accessories:

- 1. Front Fascia: Aluminum extrusion that conceals front and underside of roller and operating mechanism and attaches to roller endcaps without exposed fasteners.
- 2. Exposed Headbox: Rectangular, extruded-aluminum enclosure including front fascia, top and back covers, endcaps, and removable bottom closure.
- 3. Endcap Covers: To cover exposed endcaps.
- 4. Recessed Shade Pocket: Rectangular, extruded-aluminum enclosure designed for recessed ceiling installation; with front, top, and back formed as one piece, end plates, and removable bottom closure panel.
- 5. Closure Panel and Wall Clip: Removable aluminum panel designed for installation at bottom of site-constructed ceiling recess or pocket and for snap-in attachment to wall clip without fasteners.
- 6. Side Channels: With light seals and designed to eliminate light gaps at sides of shades as shades are drawn down. Provide side channels with shadeband guides or other means of aligning shadebands with channels at tops.
- 7. Bottom (Sill) Channel or Angle: With light seals and designed to eliminate light gaps at bottoms of shades when shades are closed.
- 8. Installation Accessories Color and Finish: As selected from manufacturer's full range.

2.3 SHADEBAND MATERIALS

- A. Shadeband Material Flame-Resistance Rating: Comply with NFPA 701. by a qualified testing agency. Identify products with appropriate markings of applicable testing agency.
- B. Light-Filtering Fabric: Woven fabric, stain and fade resistant.
 - 1. Source: Roller shade manufacturer.
 - 2. Type: Woven polyester and PVC-coated polyester
 - 3. Weave: Mesh
 - 4. Roll Width: 48 inches (1229 mm)
 - 5. Orientation on Shadeband: Up the bolt
 - 6. Openness Factor: 5percent.
 - 7. Color: selected by Architect from manufacturer's full range.
- C. Light-Blocking Fabric: Opaque fabric, stain and fade resistant.
 - 1. Source: Roller shade manufacturer
 - 2. Type: Fiberglass textile with PVC film bonded to both sides
 - 3. Roll Width: 48 inches (1229 mm)
 - 4. Orientation on Shadeband: Up the bolt
 - 5. Color: As selected by Architect from manufacturer's full range

2.4 ROLLER SHADE FABRICATION

- A. Product Safety Standard: Fabricate roller shades to comply with WCMA A 100.1
- B. Unit Sizes: Fabricate units in sizes to fill window and other openings as follows, measured at 74 deg F (23 deg C):
 - 1. Between (Inside) Jamb Installation: Width equal to jamb-to-jamb dimension of opening in which shade is installed less 1/4 inch (6 mm) per side or 1/2-inch (13-mm) total, plus or minus 1/8 inch (3.1 mm). Length equal to head-to-sill or -floor dimension of opening in which shade is installed less 1/4 inch (6 mm), plus or minus 1/8 inch (3.1 mm).
 - 2. Outside of Jamb Installation: Width and length as indicated, with terminations between shades of end-to-end installations at centerlines of mullion or other defined vertical separations between openings.
- C. Shadeband Fabrication: Fabricate shadebands without battens or seams to extent possible, except as follows:
 - 1. Vertical Shades: Where width-to-length ratio of shadeband is equal to or greater than 1:4 provide battens and seams at uniform spacings along shadeband length to ensure shadeband tracking and alignment through its full range of movement without distortion of the material.
 - 2. Railroaded Materials: Railroad material where material roll width is less than the required width of shadeband and where indicated. Provide battens and seams as required by railroaded material to produce shadebands with full roll-width panel(s) plus, if required, one partial roll-width panel located at top of shadeband.

PART 3 - EXECUTION

3.1 ROLLER SHADE INSTALLATION

- A. Install roller shades level, plumb, and aligned with adjacent units according to manufacturer's written instructions.
 - 1. Opaque Shadebands: Located so shadeband is not closer than 2 inches (51 mm) to interior face of glass. Allow clearances for window operation hardware.
- B. Electrical Connections: Connect motor-operated roller shades to building electrical system.
- C. Adjust and balance roller shades to operate smoothly, easily, safely, and free from binding or malfunction throughout entire operational range.
- D. Clean roller shade surfaces, after installation, according to manufacturer's written instructions.
- E. Replace damaged roller shades that cannot be repaired, in a manner approved by Architect, before time of Substantial Completion.

END OF SECTION 122413

ProColor 652

Touch technology and collaboration are brought to life with the brilliance of our 4K ultra high-definition LCD flat panel Android display.



Features

- Up to 20 single-point users or 10 dual-touch and gestures users with Touch 360° interactivity, driving collaborative learning to a new level.*
- Built-in Android OS for touch control plus Whiteboard app.
- 4K video resolution (3,840 x 2,160).
- LED backlighting for energy efficiency.
- Includes MimioStudio™ classroom software with 3-device MimioMobile™ license.

* Multi-touch available on Windows systems. Mac and Linux are single touch.

Options

- Internal Windows 10 PC (available with Intel i5 or i7)
- Wall mount
- Wi-Fi module

Specifications

Dimensions and Weight	
Overall Dimensions (W x H x D)	1,522 mm x 944 mm x 98 mm (61.1 in. x 37.2 in. x 3.9 in.)
Net Weight	46kg (101.4 lb.)
Packaged Dimensions (W x H x D)	1,697 mm x 1,071 mm x 220 mm (66.8 in. x 42.2 in. x 8.7 in.)
Gross Weight	57 kg (126 lb.)
Effective Screen Size (W x H)	1,428 mm x 803 mm (56.24 in. x 31.63 in.)
Active Screen Size (Diagonal)	65 in.
Image	
Display Format Native Resolution	3,840 x 2,160
Aspect Ratio	16:9
Picture Response Time (Gray to Gray)	8 ms
Refresh Frequency	60 Hz
Pixel Pitch	0.496 mm x 0.372 mm
Pixel Density	68.3 DPI (dots per inch)
Panel Resolution	3,840 x 2,160
Display Colors	1.07 B (10-bit)
Brightness (typical)	350 nits
Contrast Ratio	1,200:1

Viewing Angle	Hor. 178°, Ver. 178°
Backlight Life (estimated)	50,000 hours
Touch Tracking	
Tracking Technology	Touch 360° Infrared
Touch Points Operating Systems	20-touch: Windows 7+ Single touch: Mac OS 10.8+, Linux, Chrome
Touch Tool	Stylus, finger (even if gloved), or solid object
Tracking Accuracy	+/-2mm (0 in.)
Tracking Read Speed	>125 frames/s
Tracking Response Time	12 ms
Tracking Points	32,767 x 32,767
Safety	
Anti-Glare Glass	Yes
Protective Glass	4 mm tempered glass Level 7 Mohs
Connections	
Input/Output	Input: - VGA x 1 - HDMI-4K V1.4 x 2 - HDMI-4K V2.0 x 1 - PC audio x 1 - DisplayPort x 1 Output: - HDMI x 1 - Earphone out x 1 - Digital audio output coax x 1 USB: - USB 2.0 x 4 (2 in front, 1 on side, 1 on the bottom) - USB 3.0 x 2 (1 in front, 1 on side) - USB 2.0 Type-B for touch control (on side) - RS-232 x 1 - LAN RJ-45 x 1

Audio	
Output	12 W x 2
Sound System	Stereo
Equalizer	Yes
Sound Status Memory	Yes
Balance	Yes
Environmental	
Storage Temperature	-20° to 60° C (-4° to 140° F)
Storage Humidity	10% to 90%
Operating Temperature	0° to 40° C (32° to 104° F)
Operating Humidity	10% to 90%
Power Requirement	100–240 VAC 60/50 Hz
Power Consumption (Operating)	265 W
Power Consumption (Sleep Mode)	<0.5 W
Mount	
Mounting Screw Size	M8 x 25 mm
VESA Form Factor	600 x 400 mm
Accessories	
HDMI Cable	1 x 3 m
AC Power Cable	1 x 3 m
USB Cable	1 x 5 m

Passive Stylus	3 x magnetic
Remote Control	1 (with batteries)
Wall Mount	Optional
Internal PC Module	Optional
Android	
Version	Android 5.1 "Jelly Bean"
CPU	ARM Cortex A53 Dual Core
GPU	Quad Core
RAM	2 GB
ROM	16 GB

What's in the box:

Hardware

- Magnetic stylus x 3
- Remote control with batteries

Documentation

- MimioStudio license
- Warranty card
- QuickStart Guide

Cables

- HDMI cable (3 m)
- USB A-to-B for touch (5 m)
- US power cord (3 m)

Drawings

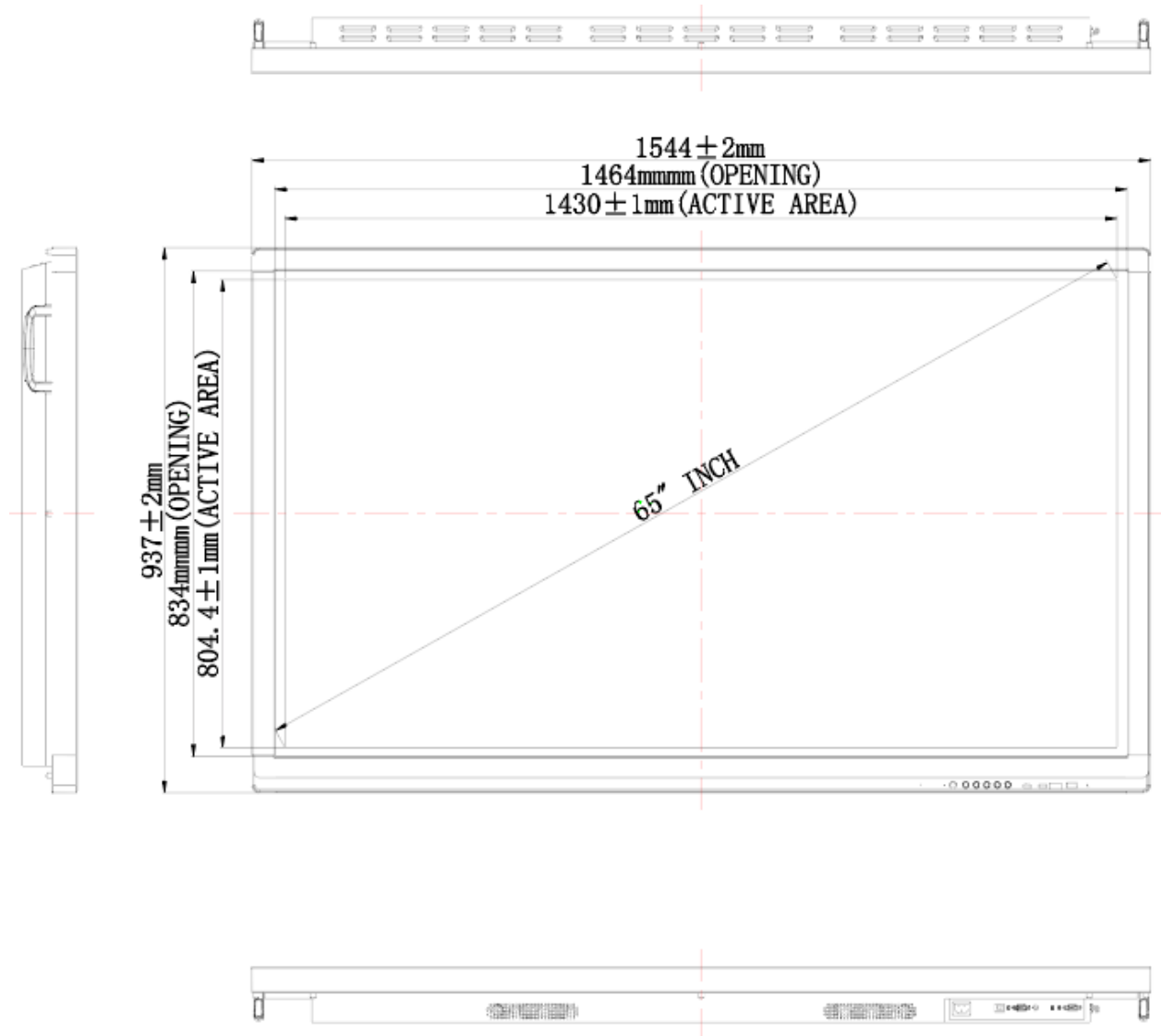

Connections

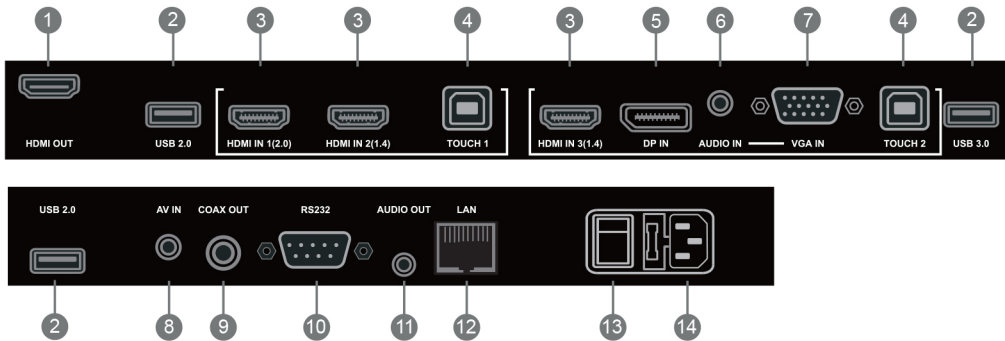

Items	Function description
① HDMI OUT	Displays whatever is on the screen, including Android annotation.
② USB	Connect USB devices such as mobile hard disk, U disk, USB keyboard and mouse, USB drives, etc.
③ HDMI IN	HDMI input
④ TOUCH	Touch signal output for connection to external computer
⑤ DP	DisplayPort input
⑥ AUDIO IN	Line level audio input
⑦ VGA IN	VGA input
⑧ AV IN	Composite video + audio input - 3.5mm 4-conductor
⑨ COAX OUT	Digital audio output - "RCA" connector
⑩ RS-232	Control interface
⑪ AUDIO OUT	Output to an external amplifier and speaker
⑫ LAN	RJ-45 connector
⑬ AC SWITCH	Master power switch
⑭ AC IN	AC power input

HDMI = High-definition multimedia interface

Specifications are subject to change without notice.

DNA structure



P12 LTU ultra-wide laser projector

Lessons come to life in an interactive area as large as 140 inches wide. The ultra-wide, touch-enabled area allows up to 10 students to simultaneously collaborate in beautiful, engaging clarity.

Imagine being able to create an interactive area as wide as 140 inches diagonal! Our ultra-wide projector does just that, bringing large-scale collaboration to the classroom.

The P12 LU ultra-wide projector makes stunning collaborative, 10-touch* interactivity** possible!

Its laser illumination saves you time and resources. There's no lamp to fail or change, and a 20-year laser lifespan.***

- Complete education solution—comes with easy-to-learn and easy-to-use MimioStudio™ classroom software.
- Software and MimioMobile™ app enable collaboration and assessment either at the front of the room or on almost any student device.
- A solution that makes it easy to gauge and personalize student learning.
- Use the entire 140-inch space as an interactive collaborative space, maximizing the ability to work with individual students or in small groups.
- Laser projection means no bulbs to change—ever.
- Analog and digital audio/video connections ensure compatibility with virtually any PC.
- Ethernet LAN connectivity for central management and control.



“The P12 LU allows me to have a huge interactive collaborative space for my students—and I still have my whiteboard.”

Travis Rink, Science Teacher

To learn more, visit mimio.boxlight.com/laserprojector or call 866.972.1549.

* Multi-touch works on Windows only.

** Also available in pen-only and non-interactive models.

*** Defined as a typical school year of 200 days with 5 hours of use per day.



MimioStudio software—so easy to use and engaging, your teachers will use it every day.

The MimioTeach™ interactive whiteboard includes the dynamic MimioStudio classroom software. It connects the Boxlight products, so using other tools—from the document camera to the pen tablet—is quick and easy. MimioStudio software allows educators to create interactive lessons and collaborative activities, and perform real-time formative assessment.

Take learning even further with our MimioMobile app, which brings group learning and collaboration to almost any device.



Specifications

OS	Software Requirements	MimioStudio 11.6 or higher on a Windows, Mac, or Linux OS
	Brightness	3,100 lumens
Display	Light Source	Laser Diode x 23
	Laser Life (typical)	20,000 hours
	Native Aspect Ratio	16:6
	Native Resolution	1920 x 720 (16:6)
	Image Size (diagonal)	120 in. - 140 in. / 305 cm - 356 cm
	Keystone Correction	Vertical: ±5°
	Contrast Ratio (typical)	1,800:1 (10,000:1 high contrast)
	Color Reproduction	16.7 million colors (R/G/B 10-bit)
	Projection Lens	f/2.4
	Throw Ratio	Ultra-short throw of 0.25
	Focus Type	Manual
	Projection Technology	Digital Light Processing (DLP), utilizing a 6-segment color wheel.
	Closed Captioning	Based on TI DDP4421 spec, CC1/CC2/CC3/CC4 supported
	Audio/Video Connections	Digital A/V Inputs
Video Analog Inputs		VGA x 1 VGA in/out switched* x 1 Composite x 1
Video Analog Outputs		VGA in/out switched x 1
Audio Analog Inputs		Stereo line 3.5 mm x 1 Stereo line RCA jacks x 1 Mic level 3.5 mm x 1
Audio Analog Outputs		Line out 3.5 mm x 1
Speaker		1 speaker 10 W
Control	LAN	Standard using RJ-45 connector
	LAN Control Protocols	Crestron
	Laser Curtain DC Power	3.5 mm

Mech	Mounting	Front or rear projection, wall, or ceiling mount**
	Security	Kensington Lock >20 kg
General	Power Supply	AC 100–240 V 50-60 Hz
	Power Consumption (typical)	Full : 335 W±15% ECO : 225 W±15% Standby: < 0.5 W Touch Mode***
	Operating Temperature	5-40° C (41-104° F) non-condensing
	Fan Noise	Full mode : 36dBA (typical) / 38dBA (maximum) ECO mode : 32dBA (typical) / 35dBA (maximum)
Interactivity****	Touch Points****	10
	Calibration	Auto/Manual
	Laser Curtain Module	IR Laser 825 nm
	Laser Curtain Power	12V/0.3A from projector
	Visible Laser Curtain Alignment	- Visible light 650 nm - Optical power < 0.39 mW - Dot size at focus point 10 mm
	Whiteboard Non-planarity	<3 mm
	Laser Safety	IEC 60825-1 Class-1
	Interactivity	USB Mini

* One connector switchable between VGA in or out.
 ** Ceiling and table mount require third-party bracket.
 *** LAN/RS-232/VGA out are off.
 **** Multi-touch works on Windows only.
 ***** Laser Curtain specifications only apply to touch model.

What's in the Box

P12 LTU laser touch-interactive projector Projector, AC power cord (4m), HDMI cable (5m), remote control with battery, mini-USB cable (5m), 2 magnetic static pens, laser curtain module, DC power cable for laser curtain, and MimioStudio software license.

P12 LIU laser pen-interactive projector Projector, AC power cord (4m), HDMI cable (5m), remote control with battery, mini-USB cable (5m), 2 IR pens, and MimioStudio software license.

N12 LNU laser non-interactive projector Projector, AC power cord (4m), HDMI cable (5m), remote control with battery, and mini-USB cable (5m).



We know how important it is to feel confident in the tools you use every day, so we make sure you can count on our products and service. We offer flexible training resources, our MimioConnect™ online educator community, and US-based in-house, dedicated product specialists. Email, chat, or call us 24/7/365 and we will be there to support you.

To learn more, visit mimio.boxlight.com/laserprojector or call 866.972.1549.

Specifications subject to change without notice.



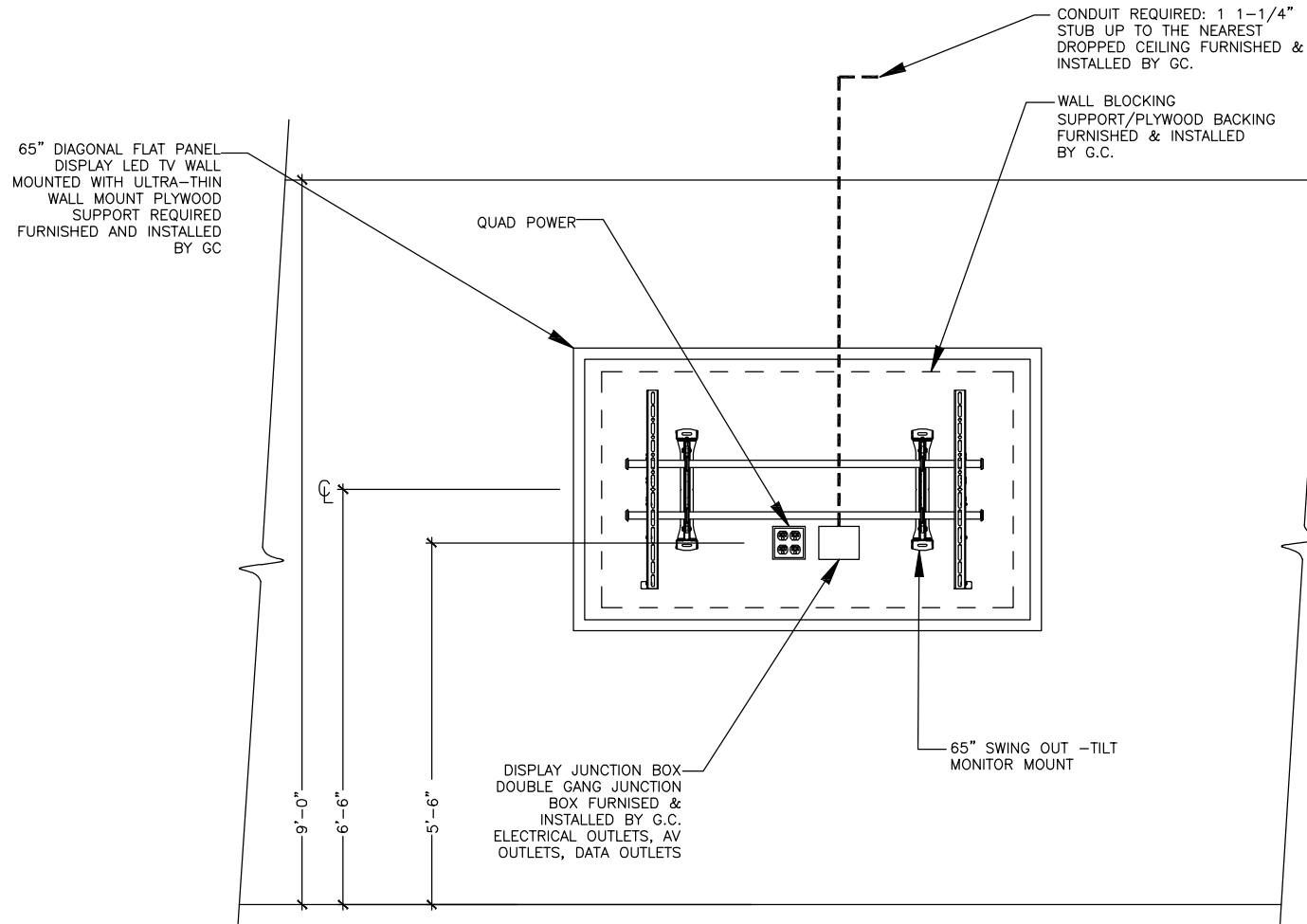

FRONT ELEVATION

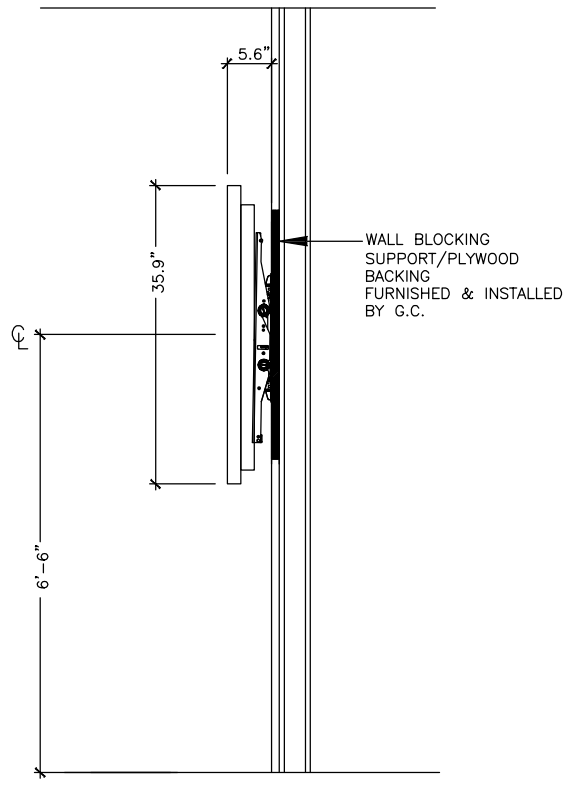

SECTION

TYPICAL TV DISPLAY ELEVATION & SECTION



fits standard peg hooks

heavy duty 1/4"



1 2 3 4 5 6 7 8 9 10 11 12 13 14 15 16 17

[View Pricing](#)

Plastic PegBoard

PegBoard PX™ is a great organizational tool. Crafted from the highest industrial grade of polypropylene plastic, it will never fade, dry out, crack or peel over time and is completely impervious to water and moisture. Our included Self-Stick Spacers™ make installation easy - just screw into the wall and it is ready to go.

Available in an assortment of standard sizes as well as any custom size up to 48"x96"- the PegBoard PX™ is great for hospitals, food preparation areas, kids rooms, laundry, bedroom, bathroom, play room and more. It's easy to clean, UVA safe, stain proof, unaffected by chemicals and oils and great for interior and exterior use. Our 1/4" thick plastic has standard 9/32" diameter peg hook holes spaced on 1" centers allowing any standard hook or accessory to fit. A workspace could not be complete without plenty of pegboard. This versatile tool offers plenty of space for storing frequently used tools within plain view and easy reach. Moreover, it is adaptable – peg hooks and accessories can be custom arranged and continually rearranged to meet your specific needs.

For industry, factory, office, hospitals, restaurants, kitchens, playrooms, and more. Looks great, works even better™.

Our team loves our new PegBoard PX™ units. We searched all over for a durable, high quality plastic pegboard and settled on diamondLife. Boy are we glad we did. Last year we had purchased something else from a different company and the units were flimsy and cheap. You get what you pay for. Thank you for your gracious customer service, quick turn around, and super nice product. We will definitely be ordering more!

- Sarah G. (New York, NY)

Cleaning	Features
Customer Reviews	Downloads
	52 Photos



142 Customer Reviews | ★★★★★ 4.8 out of 5 stars



"The plastic peg board worked great. I had built some down draft tables for a restoration company and they would get the regular peg board damp and it would warp. The plastic board seems to be working very well no warping."

Shawn M. (Laurel, MT)
- purchased [PegBoard PX™](#)

1 Select Color 2 Order



Shopping Cart

Free Tote Bag
with \$500 purchase



Free Diamond Plate Cap
with \$1000 purchase



- 1** Review Shopping Cart
- 2** Enter Payment Information
- 3** Order Complete

UPDATE TOTALS

Product#	Description	Price	Qty	Amount
HPBPX	PegBoard PX™ • Material: Plastic • Color: Black • Size: 4' x 6' • Includes (40) Self-Stick Spacers™, 0.625"L	\$156.00	<input type="text" value="1"/>	\$312.00 <input type="checkbox"/>
HWA	Expanding Hollow Wall Anchor • Fits 1/8" to 1/2" thick wall • Qty: 6 Pack	\$4.99	<input type="text" value="1"/>	\$4.99 <input type="checkbox"/>
SCR	Screw • #14 x 2-1/2" Phillips Pan Head • Qty: 6 pack	\$1.99	<input type="text" value="1"/>	\$1.99 <input type="checkbox"/>
HPBSSS.SM	Self-Stick Spacers™ • Qty: 6 Pack • Length: 5/8" • Fits: PegBoard PX, PegBoard HB, and PegBoard MX with BackingBoard	\$1.99	<input type="text" value="1"/>	\$1.99 <input type="checkbox"/>
HPBHOK.60	PegBoard Hooks 60pc Bundle • 16pc 5/8" Curvd Hk • 16pc 1-1/2" Angl Hk • 10pc 4" Sngl Hk • 6pc 3/4" Plier Hldr • 3pc 3/4" Loop TI Hldr • 3pc 6" Dble Hk • 2pc 8" Shlf Brkt • 2pc 4" Loop Hook • 1pc 1-1/2" Angl Mltpl TI Hldr • 1pc 3/4" Loop Mltpl Tool Hldr	\$59.00	<input type="text" value="1"/>	\$59.00 <input type="checkbox"/>
HSAFETIP	Safety Tips • Qty: 25 pk	\$5.00	<input type="text" value="1"/>	\$5.00 <input type="checkbox"/>
HLSHDH	Super Hook Power Drill Holder • Size: 5" wide x 4" deep x 3-1/2" high	\$6.00	<input type="text" value="1"/>	\$6.00 <input type="checkbox"/>
		Sub-Total:		\$390.97
		Shipping:	Get Shipping Cost	
		Total:		\$390.97

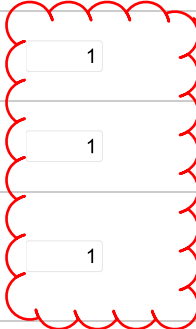

contractor to provide and confirm quantities required to support and install ea pegboard

CHECKOUT

• SAVE CART

CONTINUE SHOPPING

PegBoard | SlatWall | Grid | Shelving | Moldings | Wainscoting | Metal by the Piece | Trailer Stone Guard | Wall Plate Covers Flooring | Parking Aids | Impact Protection | Door Hardware Systems | Magnetic Board | FreeStanding Displays | Custom Signage | Fasteners | Wall Organizers | Wine Rack

home | about us | products | gallery | testimonials | in-the-news | faq | contact | help

Copyright © 2021 diamondLife. All rights reserved. | [Terms of Use](#)

[LEGAL NOTICE TO PICSCOUT, GETTY IMAGES, PICSCOUT CLIENTS, and CYVEILLANCE INTELLIGENCE CENTER their subsidiaries, agents, and assigns:](#)

You are prohibited from accessing this site

Home > School Furniture Brands > Virco > Virco Activity Tables > Virco Library Tables > **Virco Text Series Tables**

Virco Text Series Table, 30" x 60" x 1-1/8" Adjustable-Height Top (Virco TE30608DADJ)



Virco TE30608DADJ

 [VIEW LARGER PHOTO](#)

[EMAIL A FRIEND](#)



Alternative Views:



Seen a lower price? or have a large order? Call us toll-free for a special quote at (877) 398-6449.

SchoolOutlet Price: \$397.85

Product Code: TE30608DADJ



6 - 12 Weeks



① TABLE LAMINATE TOP

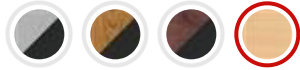

Fusion Maple Top / Fusion Maple Edge

1



ADD TO CART

Over \$1000

Description

Designed by Peter Glass and Bob Mills, TEXT™ tables for classroom, lecture and seminar settings combine proven Virco construction with double-post elliptical legs, swooping yokes, and arched feet for exceptional elegance. This adjustable TEXT model with a top height range of 26" to 34" has a 30" x 60" high-pressure laminate work surface that's 1-1/8" thick.

PRODUCT FEATURES

- ✓ **10 year limited warranty**
- ✓ Double-Upright
- ✓ Designed by Peter Glass and Bob Mills
- ✓ high-pressure laminate work surface

Specifications:

- ✓ 30" x 60" x 1-1/8"
- ✓ Top Width: 60"
- ✓ Top Depth: 30"
- ✓ Weight: 106
- ✓ Adjustable Table Height: 26" - 34"



100% SATISFACTION GUARANTEE!

NEED HELP?

8am to 8pm EST *HELP & SUPPORT*

Phone

1-877-398-6449

Fax

1-877-225-2797

297 Kingsbury Grade Suite 133
Mailing: PO Box 4470
Lake Tahoe, NV 89449-4470



Company Info

[About Us](#)

[Become an Affiliate](#)

[Privacy Policy](#)

[Shipping & Returns](#)

[Bookmark Us](#)

[Coupons](#)

Top Categories

[Desks](#)

[Air Purifier](#)

[Chairs & Seating](#)

[Hygiene Equipment](#)

[Early Childhood](#)

[Home School](#)

AV Equipment & Lecterns

[Tables](#)

Customer Links



Contact Us



© 2004 - 2021 SchoolOutlet.com. All Rights Reserved.

Ghent

Centurion Magnetic Markerboard w/ SmartPak Accessory Tray (8' W x 4' H)

★★★★★ 5.0 (1) [Write a review](#) [Post a question](#)

[Start a Live Chat](#)



\$438.99

MSRP: ~~\$804.00~~

You Save: \$362.01 (45%)

SKU: GHE-A2M48

[Calculate Shipping](#)

Share:

Select Options:

Style:

Dimensions:

Quantity:

Add to Cart

Specifications	Description
Writing Surface:	Porcelain-on-steel
Magnetic:	Yes
Backing Material:	5/8" fiberboard w/ mylar foil backing
Frame Material:	Aluminum
Tray Material:	Aluminum
Warranty:	50 years
Other Info:	Includes a marker tray, felt eraser, 4 markers (black, blue, green & red) & some mounting hardware
Overall Width:	8'
Overall Height:	4'
Assembly:	Assembled
Product Weight (Lbs):	73
Shipping Method:	Freight

Similar Items	You May Also Like	Recently Viewed
	<p>Best-Rite Manufacturing Whiteboard Track System w/ Sliding & Base Panels \$594.99 - \$698.99</p>	
	<p>Marsh Industries 5' High Pro-Lite Magnetic Markerboard \$435.99 - \$1,239.99</p>	
	<p>Ghent Reversible Magnetic Hygienic Porcelain Whiteboard w/ Aluminum Frame \$614.99 - \$1,329.99</p>	
	<p>Ghent Double-Sided Markerboard \$323.99 - \$523.99</p>	

★★★★★ 5.0 | [1 Review](#)

<input type="text" value="Search topics and reviews"/>		1 Review	1 Question	1 Answer
--	--	--------------------------	----------------------------	--------------------------

Questions

[Post a question](#)

Sister Mary Lou · 3 years ago

What does it mean when it says in the description comes with "some" mounting material? Doesn't this board come with all mounting material needed?

1
answer

Originally posted on [Centurion Magnetic Markerboard w/ SmartPak Accessory Tray & Maprail \(12' W x 4' H\)](#)

School Outfitters · 3 years ago

The mounting material included are the L-brackets and screws to attach the board to the brackets but not the hardware to attach the brackets to the wall. The hardware used depends on the wall type. If you have any other questions, please contact our Sales team at 1-800-260-2776.

Helpful? **Yes** · 0 **No** · 0 [Report](#)

Rating Snapshot

Select a row below to filter reviews.



Average Customer Ratings

Overall  5.0

1 Ratings-Only Review

[Back to top](#)

<p>Sales</p> <p>1-800-260-2776 M-F: 8-7 Eastern</p> <p>Fax: 1-800-494-1036 Email Sales Live Chat Search My Quotes</p>	<p>Customer Care</p> <p>1-866-619-1776 M-F: 8-7 Eastern</p> <p>Contact Customer Service My Account Order History Track Order Report a Problem Returns Policy</p>	<p>Resources</p> <p>Brochures & Catalogs Buying Guides Co-ops & Contracts Email this Page Frequently Asked Questions Site Map Blog</p>	<p>Company Info</p> <p>School Outfitters 3736 Regent Ave. Cincinnati, OH. 45212-3724</p> <p>About Us Careers Privacy Policy</p>
---	--	---	--

Sign up to receive offers & updates:

Accepted Payment Types:



Join the Conversation:



Shop with Confidence:



Ghent

Vinyl Tackboard w/ Wrapped Edges (6' W x 4' H)

★★★★★ 5.0 (1) [Write a review](#) [Post a question](#)

[Start a Live Chat](#)



\$147.99

MSRP: ~~\$209.00~~

You Save: \$141.01 (49%)

SKU: GHE-12UV46-W

[Calculate Shipping](#)

On Sale

Share: [Email](#) [Pinterest](#)

Select Options:

Frame Style: **Wrapped Edges**

Dimensions: **6' W x 4' H**

Choose a tackboard color:



Quantity:

Add to Cart

Specifications	Description
Board Material:	Washable, burlap-textured vinyl
Frame Style:	Unframed
Warranty:	10-year limited
Overall Width:	6'
Overall Height:	4'
Assembly:	Assembled
Returnable:	No
Product Weight (Lbs):	29
Shipping Method:	Freight

Similar Items	You May Also Like	Recently Viewed
	Screenflex Acoustical Wall Panel \$136.99 - \$280.99	
	Marsh Industries Natural Cork Board w/ Wood Frame \$41.99 - \$663.99	
	Ghent Outdoor/Indoor Enclosed Vinyl Tackboard w/ One Door \$184.99 - \$270.99	
	Ghent Enclosed Rubber Tackboard w/ One Door \$167.99 - \$278.99	

★★★★★ 5.0 | [1 Review](#)

<input type="text" value="Search topics and reviews"/>	1 Review	8 Questions	8 Answers
--	--------------------------	-----------------------------	---------------------------

Questions

[Post a question](#)

1-8 of 8 Questions

Sort by: Most helpful answers ▾

Anonymous · a month ago
can these with stand lots of push pins without ugly holes?

1
answer

Originally posted on [Vinyl Tackboard w/ Wrapped Edges \(12' W x 4' H\)](#)

School Outfitters · a month ago

Yes, the washable, burlap texture surface hides holes caused by pins and tacks.

Helpful? **Yes · 0** **No · 0** **Report**

Denise · 5 months ago

What is the thickness of the cork board

1
answer

Originally posted on [Vinyl Tackboard w/ Wrapped Edge \(5' W x 4' H\)](#).

School Outfitters · 5 months ago

This vinyl tackboard is 3/8-inches thick.

Helpful? **Yes · 1** **No · 0** **Report**

Abby · a year ago

We cannot use staples or tacks or pushpins at our school. Would painter's tape work with this surface to hang students' artwork and such?

1
answer

Originally posted on [Vinyl Tackboard w/ Aluminum Frame \(24" W x 18" H\)](#)

School Outfitters · a year ago

The surface has a texture to it. You could use tape but it may not hold well. Have you considered either display rails with clear clips to hold artwork or a magnetic board? See below for two options:

https://www.schooloutfitters.com/catalog/product_family_info/pfam_id/PFAM76

https://www.schooloutfitters.com/catalog/product_info/pfam_id/PFAM22285/products_id/PRO40511

Helpful? **Yes · 0** **No · 0** **Report**

maureen · a year ago

Do you do custom sized wrapped edge boards? 25x51"?

1
answer

Originally posted on [Vinyl Tackboard w/ Wrapped Edge \(5' W x 4' H\)](#).

School Outfitters · a year ago

No, we do not offer custom sized boards.

Helpful? **Yes · 0** **No · 0** **Report**

deb2019 · 2 years ago

Can papers be stapled to this product or would i need to use push pins?

1
answer

Originally posted on [Vinyl Tackboard w/ Aluminum Frame \(8' W x 4' H\)](#).

School Outfitters · 2 years ago

For minimal damage and easy removal we recommend using push pins and tacks only.

Helpful? **Yes · 0** **No · 0** **Report**

Kristopher Kaufman · 3 years ago

Do you offer custom sizes?

1
answer

Originally posted on [Vinyl Tackboard w/ Aluminum Frame \(24" W x 18" H\)](#)

School Outfitters · 3 years ago

No, we are not able to offer custom boards.

Helpful? **Yes · 0** **No · 0** **Report**

BarbH · 3 years ago

Can this board be hung vertically?

1
answer

Originally posted on [Vinyl Tackboard w/ Aluminum Frame \(24" W x 18" H\)](#)

School Outfitters · 3 years ago

We do not recommend hanging boards vertically.

Helpful? **Yes · 0** **No · 0** **Report**

M Ayres · 3 years ago

Is this product flame retardant?

1
answer

Originally posted on [Vinyl Tackboard w/ Wrapped Edges \(12' W x 4' H\)](#)

School Outfitters · 3 years ago

This product has a Class A fire rating, which means that it will reduce the speed at which flame spreads, however, it is not flame retardant. If you have any other questions, please contact our Sales team at 1-800-260-2776.

Helpful? **Yes · 0** **No · 0** **Report**

Reviews

[Write a review](#)

Rating Snapshot

Select a row below to filter reviews.

5 ★	<input type="text"/>	1
4 ★	<input type="text"/>	0
3 ★	<input type="text"/>	0
2 ★	<input type="text"/>	0
1 ★	<input type="text"/>	0

Average Customer Ratings

Overall  5.0

1 Ratings-Only Review

[Back to top](#)

Sales

1-800-260-2776
M-F: 8-7 Eastern

Customer Care

1-866-619-1776
M-F: 8-7 Eastern

Resources

[Brochures & Catalogs](#)
[Buying Guides](#)
[Co-ops & Contracts](#)

Company Info

School Outfitters
3736 Regent Ave.
Cincinnati, OH.

Fax: 1-800-494-1036
Email Sales
Live Chat
Search My Quotes

Contact Customer Service
My Account
Order History
Track Order
Report a Problem
Returns Policy

Email this Page
Frequently Asked Questions
Site Map
Blog

45212-3724
About Us
Careers
Privacy Policy

Sign up to receive offers & updates:

Accepted Payment Types:



Join the Conversation:



Shop with Confidence:



Ghent

Vinyl Tackboard w/ Wrapped Edges (8' W x 4' H)

★★★★★ 5.0 (1) [Write a review](#) [Post a question](#)

[Start a Live Chat](#)



\$194.99

MSRP: ~~\$365.00~~

You Save: \$170.01 (47%)

SKU: GHE-12UV48-W

[Calculate Shipping](#)

On Sale

Share:

Select Options:

Frame Style: **Wrapped Edges**

Dimensions: **8' W x 4' H**

Choose a tackboard color: **Stone**



Quantity:

Add to Cart

Specifications	Description
Board Material:	Washable, burlap-textured vinyl
Frame Style:	Unframed
Warranty:	10-year limited
Overall Width:	8'
Overall Height:	4'
Assembly:	Assembled
Returnable:	No
Product Weight (Lbs):	39
Shipping Method:	Freight

Similar Items
You May Also Like
Recently Viewed

Ghent
[Outdoor/Indoor Enclosed Vinyl Tackboard w/ One Door](#)
\$184.99 - \$270.99

Ghent
[Enclosed Rubber Tackboard w/ One Door](#)
\$167.99 - \$278.99

Ghent
[Enclosed Fabric Tackboard w/ One Door](#)
\$188.99 - \$341.99

Best-Rite Manufacturing
[Single Panel Vinyl Mobile Floor Display](#)
\$253.99

★★★★★ 5.0 | [1 Review](#)

1 [Review](#)

8 [Questions](#)

8 [Answers](#)

Questions

[Post a question](#)

1-8 of 8 Questions

Sort by: Most helpful answers ▾

Anonymous · a month ago
can these with stand lots of push pins without ugly holes?

1 answer

Originally posted on [Vinyl Tackboard w/ Wrapped Edges \(12' W x 4' H\)](#)

School Outfitters · a month ago

Yes, the washable, burlap texture surface hides holes caused by pins and tacks.

Helpful? **Yes · 0** **No · 0** **Report**

Denise · 5 months ago

What is the thickness of the cork board

1
answer

Originally posted on [Vinyl Tackboard w/ Wrapped Edge \(5' W x 4' H\)](#).

School Outfitters · 5 months ago

This vinyl tackboard is 3/8-inches thick.

Helpful? **Yes · 1** **No · 0** **Report**

Abby · a year ago

We cannot use staples or tacks or pushpins at our school. Would painter's tape work with this surface to hang students' artwork and such?

1
answer

Originally posted on [Vinyl Tackboard w/ Aluminum Frame \(24" W x 18" H\)](#)

School Outfitters · a year ago

The surface has a texture to it. You could use tape but it may not hold well. Have you considered either display rails with clear clips to hold artwork or a magnetic board? See below for two options:

https://www.schooloutfitters.com/catalog/product_family_info/pfam_id/PFAM76

https://www.schooloutfitters.com/catalog/product_info/pfam_id/PFAM22285/products_id/PRO40511

Helpful? **Yes · 0** **No · 0** **Report**

maureen · a year ago

Do you do custom sized wrapped edge boards? 25x51"?

1
answer

Originally posted on [Vinyl Tackboard w/ Wrapped Edge \(5' W x 4' H\)](#).

School Outfitters · a year ago

No, we do not offer custom sized boards.

Helpful? **Yes · 0** **No · 0** **Report**

deb2019 · 2 years ago

Can papers be stapled to this product or would i need to use push pins?

1
answer

Originally posted on [Vinyl Tackboard w/ Aluminum Frame \(8' W x 4' H\)](#).

School Outfitters · 2 years ago

For minimal damage and easy removal we recommend using push pins and tacks only.

Helpful? **Yes · 0** **No · 0** **Report**

Kristopher Kaufman · 3 years ago

Do you offer custom sizes?

1
answer

Originally posted on [Vinyl Tackboard w/ Aluminum Frame \(24" W x 18" H\)](#)

School Outfitters · 3 years ago

No, we are not able to offer custom boards.

Helpful? **Yes · 0** **No · 0** **Report**

BarbH · 3 years ago

Can this board be hung vertically?

1
answer

Originally posted on [Vinyl Tackboard w/ Aluminum Frame \(24" W x 18" H\)](#)

School Outfitters · 3 years ago

We do not recommend hanging boards vertically.

Helpful? **Yes · 0** **No · 0** **Report**

M Ayres · 3 years ago

Is this product flame retardant?

1
answer

Originally posted on [Vinyl Tackboard w/ Wrapped Edges \(12' W x 4' H\)](#)

School Outfitters · 3 years ago

This product has a Class A fire rating, which means that it will reduce the speed at which flame spreads, however, it is not flame retardant. If you have any other questions, please contact our Sales team at 1-800-260-2776.

Helpful? **Yes · 0** **No · 0** **Report**

Reviews

[Write a review](#)

Rating Snapshot

Select a row below to filter reviews.

5 ★	<input type="text"/>	1
4 ★	<input type="text"/>	0
3 ★	<input type="text"/>	0
2 ★	<input type="text"/>	0
1 ★	<input type="text"/>	0

Average Customer Ratings

Overall  5.0

1 Ratings-Only Review

[Back to top](#)

Sales

1-800-260-2776
M-F: 8-7 Eastern

Customer Care

1-866-619-1776
M-F: 8-7 Eastern

Resources

[Brochures & Catalogs](#)
[Buying Guides](#)
[Co-ops & Contracts](#)

Company Info

School Outfitters
3736 Regent Ave.
Cincinnati, OH.

Fax: 1-800-494-1036
Email Sales
Live Chat
Search My Quotes

Contact Customer Service
My Account
Order History
Track Order
Report a Problem
Returns Policy

Email this Page
Frequently Asked Questions
Site Map
Blog

45212-3724
About Us
Careers
Privacy Policy

Sign up to receive offers & updates:

Email Address

Accepted Payment Types:



Join the Conversation:



Shop with Confidence:



PWB-FR-450

Wall Box Family

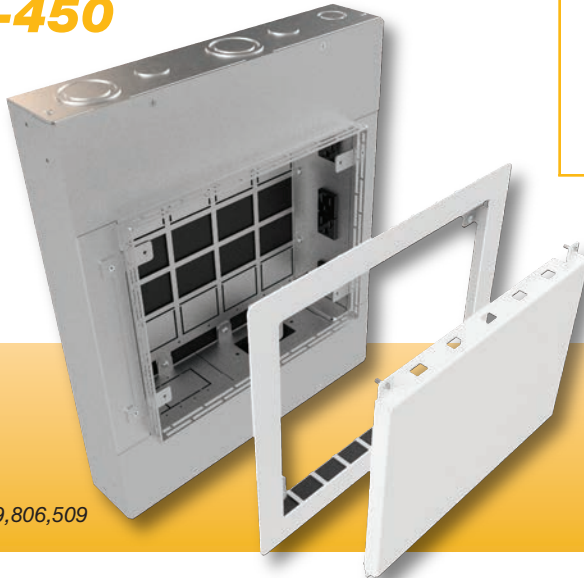

Patent 9,806,509

FSR

Metal Products Group

PWB-FR-450



FIRE RATED

DESCRIPTION

FSR is expanding its PWB series wall boxes with the PWB-FR-450. The PWB-FR-450 is a larger capacity box designed to accommodate Digital Devices with outlets and four single gang compartments and is a fire-resistant box.

The PWB-FR-450 is the only fire rated wall box in the infrastructure industry. It is designed for walls that require more opening than is allowed by code and this unique wall box eliminates the need for constructing double walls. The PWB-FR-450 complies with code and lets you hang flat screens with plenty of room for all your in-wall connections.

The PWB-FR-450 is designed for applications where you need to mount larger interfaces or equipment behind a display or in any other custom application. Integrated within the cover and its mounting frame is the proper Fire Resistive Intumescent Material, providing up to 60 minutes of protection. When closed, the PWB's cover is flush to the wall allowing a display to be mounted as close as the mounting surface will allow. The cover is ventilated top and bottom to provide convection cooling and there is a cable exit slot to pass cables from the interior of the box to a display. The covers are available in white and black.

Inside the PWB-FR-450 are four pre-wired AC outlets and four single gang mounting brackets. These brackets can be removed to provide space to mount larger devices. Behind each bracket is a 3/4" and a 1" - 1 1/2" concentric knockout which provides ample wiring flexibility and easy installation.

LITE IT

THE LITE WITH A BRAIN



LITE-it easily provides lighting in floor, wall and ceiling boxes, or anywhere a work light is needed. LITE-it can be used with all our Core Solutions. Add LITE-it to every box!

FEATURES

- Fire Rated UL Listed 1479
- Rugged 14 Gauge Steel
- Black or white cover
- Simple installation
- Four pre-wired AC outlets
- Removable Internal Brackets to accommodate larger devices
- Can accommodate Crestron DM-RMC-4K-SCALER-C
- Mounting hardware included

APPLICATIONS

- Hospitals
- Airports
- Hotels
- Conference Halls
- Shopping Malls
- Concert Halls
- Gathering Centers

ORDERING INFORMATION

PWB-FR-450-WHT	Large Format Wall box with (4) AC and (3) 1-Gang plates & (1) IPS- (Door Finish-White) FRA version
PWB-FR-450-BLK	Large Format Wall box with (4) AC and (3) 1-Gang plates & (1) IPS- (Door Finish-Black) FR version
PWB-450-MMS (Bracket only)	Optional PWB-450-MMS Bracket accommodates Digital interfaces & devices
PWB-450-DM4K (Bracket only)	Optional PWB-450-DM4SK Bracket accommodates Crestron DM-RMC-4K SCALER-C

FSR Inc.

244 Bergen Boulevard, Woodland Park, NJ 07424
Phone: 973.785.4347 · Fax: 973.785.4207
Web: www.fsrinc.com · E-mail: sales@fsrinc.com
Order Desk: 1-800-332-FSR1 LIT1611D

PWB-FR-450 DIMENSIONS

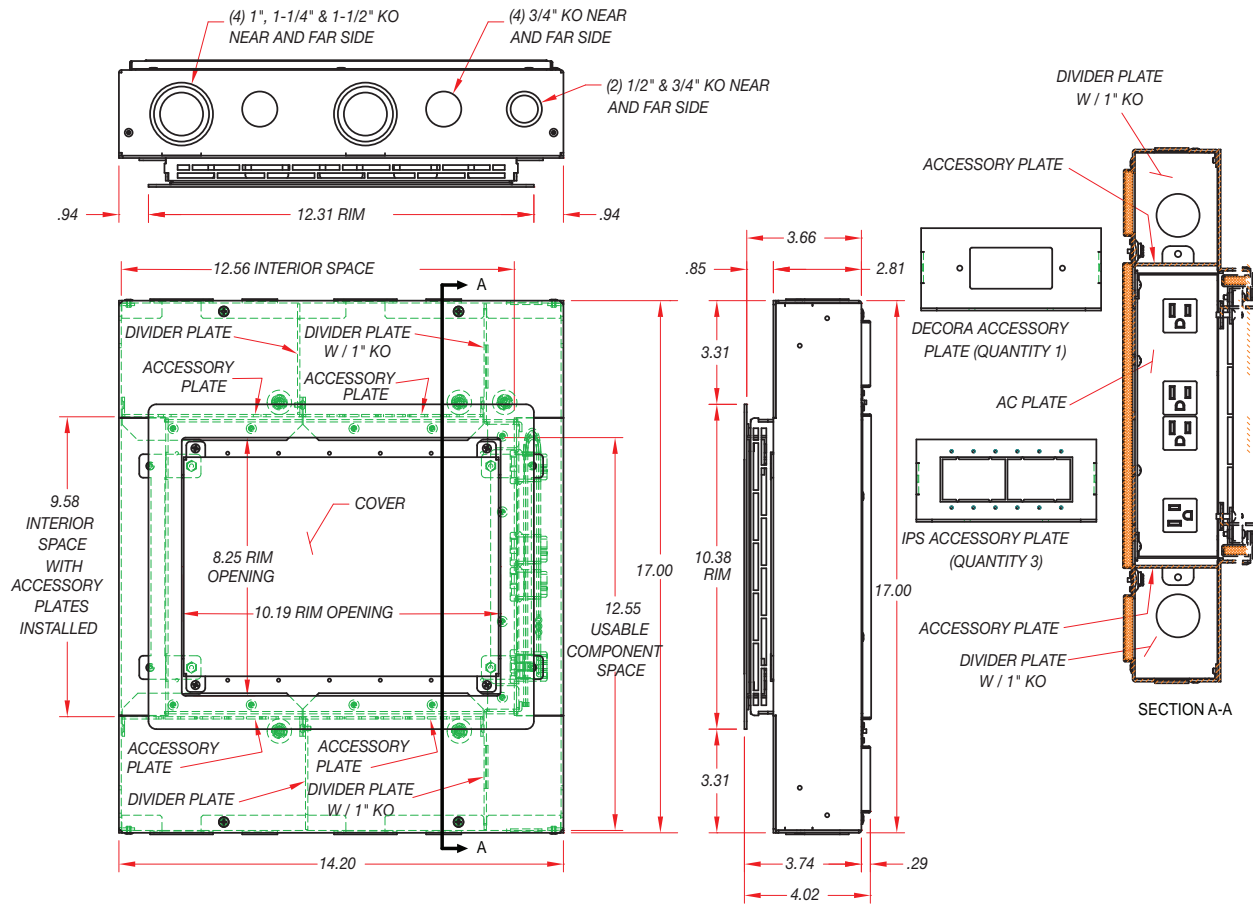

PWB-FR-450 BRACKETS

Optional PWB-450-DM4k Bracket for Crestron DM-RMC-4K-SCALER-C

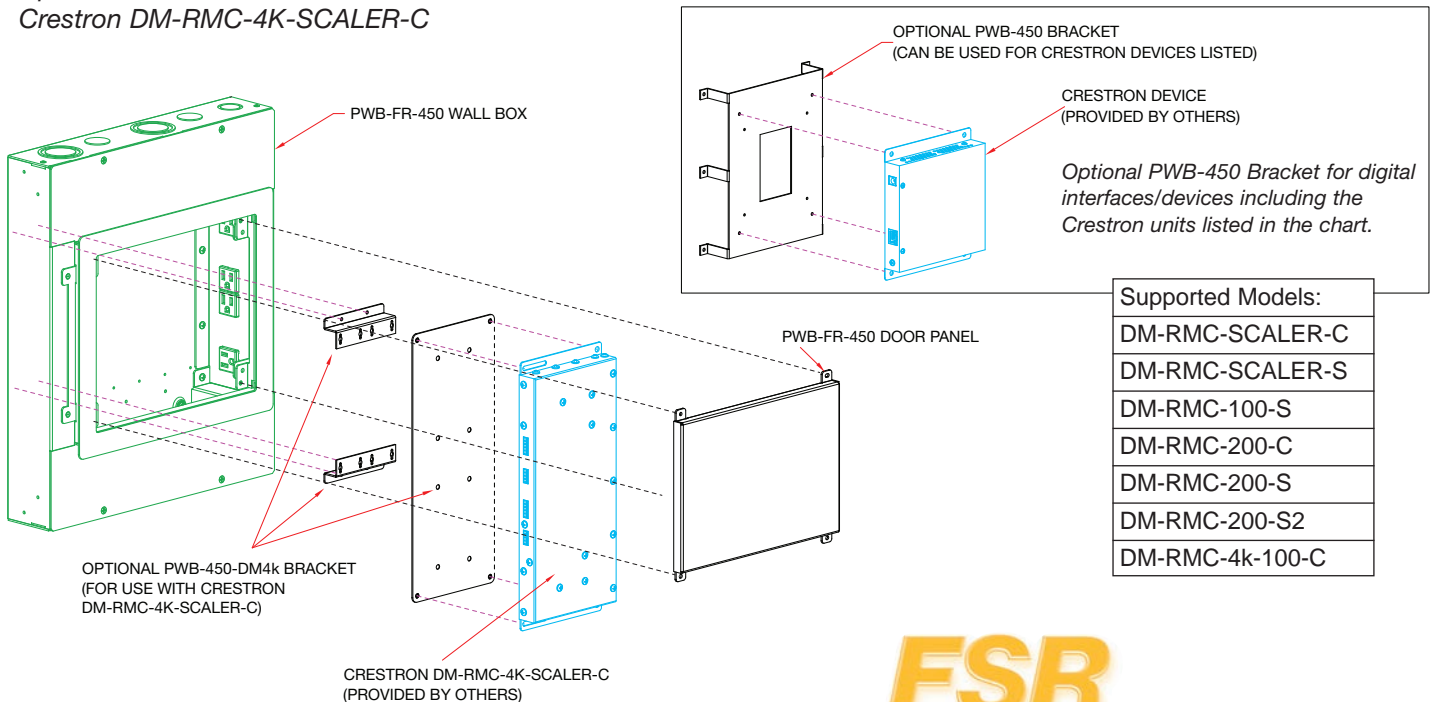

Specifications are subject to change without notice.



244 Bergen Boulevard, Woodland Park, NJ 07424
 Phone: 973.785.4347 · Fax: 973.785.4207
 Web: www.fsrinc.com · E-mail: sales@fsrinc.com



Converse Consultants

Geotechnical Engineering, Environmental & Groundwater Science, Inspection & Testing Services

June 29, 2021

Ms. Nellie J. Karbum
Facilities Planning & Development Department
San Bernardino City Unified School District
956 West 9th Street
San Bernardino, California 92411

Subject: **SUPPLEMENTAL ASBESTOS SURVEY & SUMMARY OF SURVEY RESULTS**
San Bernardino High School
Classroom Buildings M1/M2, M3, and M4
1850 North E Street
San Bernardino, California
Converse Project No. 18-16-106-04

Ms. Karbum:

Attached is a summary of the *Supplemental Asbestos Survey* completed on June 18, 2021 for the referenced property. Our work was completed in general accordance with our May 7, 2021 proposal. The survey was completed by Rodney Stansfield, a Certified Asbestos Consultant.

On Friday, June 18, 2021, bulk samples were collected of the following suspect asbestos-containing materials (ACMs) from the referenced buildings. A summary of the types of suspect materials sampled along with the analytical results is presented in the following table.

Table 1 – Suspect Materials Sampled & Analytical Results

Sample No.	Suspect Material	% Asbestos Detected	Comments
Building M1/M2 – Approximately 3,564 square feet			
SB-01 – SB-03	Roof Core (under gravel)	None Detected	Five (5) layers. All layers non detect for asbestos. Substrate is wood. Located on upper roof and lower arcade roofs.
SB-04 – SB-06	Rolled Roofing Felt	None Detected	Five to six layers. All layers non detect for asbestos. On parapets and beneath HVAC equipment. Also on east edge of arcade roof. Substrate is wood.
Additional Comments: Whiteboards and tack-boards in Building M1/M2 are attached to the walls with screws. No suspect ACM mastic was observed.			

Table 1 – Suspect Materials Sampled & Analytical Results

Sample No.	Suspect Material	% Asbestos Detected	Comments
<p>12x12 white ceiling tiles (observed above the 2x4' suspended ceiling panels) in Building M1/M2 are nailed to the wooden ceiling joists; no mastic observed. The 12x12" white ceiling tiles were previously sampled and analyzed by Pacific Environmental Company (PEC) and found to be negative for asbestos.</p> <p>No mastic was observed behind the wall-mounted mirror in the Building M1/M2 restroom.</p> <p>Converse observed suspect wall tile grout and suspect floor tile grout in the Building M1/M2 restroom. However, as the survey in that building was non-destructive in nature, those suspect ACM materials were not sampled.</p>			
Building M3 – Approximately 3,080 square feet			
SB-07 – SB-09	Roof Core (under gravel)	None Detected	Five layers. All layers non detect for asbestos. Wood substrate.
SB-10 – SB-12	Rolled Roofing Felt	None Detected	Three layers. All layers non detect for asbestos. Located on parapet walls. Wood substrate.
<p>Additional Comments: Wood wall paneling in Building M3 was attached to wooden substrate with non-suspect adhesive. No suspect mastic was observed.</p> <p>Insulated pipes along the wooden ceiling of Building M3 were observed to be wrapped in fiberglass along the pipe runs and at the elbows. No suspect materials were observed.</p>			
Building M1/M2 – Approximately 3,040 square feet			
SB-13 – SB-15	Roof Core (under gravel)	None Detected	Four layers. All layers non detect for asbestos. Substrate is wood.
SB-16 – SB-18	Rolled Roofing Felt	None Detected	Four layers. All layers non detect for asbestos. Located on parapets and under HVAC equipment. Substrate is wood.
SB-19 – SB-21	Exterior Stucco	<0.1%	A trace amount of asbestos was detected in one (1) sample of exterior stucco by PLM. The sample was further analyzed by 1,000 point count. Material is non asbestos containing as determined by 1,000 point count.
SB-22 – SB-24	Mastic to fiber wallboard Mastic	None Detected	Substrate is drywall (previously sampled and analyzed).
<p>Additional Comments: No suspect materials, which were not previously sampled, were observed in the Electrical Room in Building M4.</p>			

The bulk samples were analyzed by L.A. Testing Laboratories, Inc. located in Ontario, California. The analytical report and chain of custody documentation are attached to this letter report. A field generated sample location map is also attached to this letter report.



Summary of Survey Results

Prior surveys at the site have included the following:

- San Bernardino High School Roof, Room 3; February 5, 1999; Prepared by The Reynold Group
- Limited Asbestos and Lead Survey Report, San Bernardino High School Modernization Project, 1850 N. East Street, San Bernardino, California; August 20, 2008; Prepared by Pacific Environmental Company (PEC).
- Supplemental Asbestos Sampling Results, San Bernardino High School M1 and M2, March 23, 2011; Prepared by PEC.
- Asbestos, Lead-Based Paint & Hazardous Materials Survey Report, San Bernardino High School, Classrooms M1, M2, M3 and M4, 1850 North E Street, San Bernardino, California; June 4, 2018; Prepared by Converse.

Based on this survey and the various prior surveys noted above, a summary of the ACMs, lead-base paints (LBPs), and universal wastes is as follows:

- **ACMs**
 Roof penetration mastic on all three building roofs contains asbestos (4% to 5% chrysotile asbestos).
- **LBPs**
 The following are considered LBPs:

Building	Interior LBP Color	Exterior LBP Color
M1 and M2	Cream wall support frames and beams	Cream walls and arcade
	Grey ceramic tile	Black support poles
M3	Cream ceiling beams, door and door frame, window frame and window hatch	Grey parapet cap
	Grey doors and door frames, wall, electrical conduits, and support columns	Black, cream and red fascia
		Black door frame
M4	Cream door frames and roof support beam	Red fascia
	Grey walls	Brown door frame

- **Other Hazardous Materials**
 During the prior surveys, the following were observed:
 - A total of 98 fluorescent light fixtures were observed in the buildings. Converse assumes one ballast per fixture.

- A total of 25 smoke detectors were observed in the buildings.
- Eight (8) aerosol cans of paint were observed in Room M3.

Recommendations

The asbestos roof penetration mastics will need to be abated prior to the demolition of the buildings. The abatement will need to be completed by a licensed asbestos abatement contractor using appropriately trained and certified workers.

During the June 2021 survey, Converse observed suspect wall tile grout and suspect floor tile grout in the Building M1/M2 restroom. These materials were not sampled due to the non-destructive nature of the survey. The tile grouts will need to be samples prior to demolition and analyzed for asbestos-content or assumed to be positive and abated as ACMs.

The paint conditions varied from intact (good) to damaged. At the time of the planned renovation activities, LBPs found to be in damaged conditions (peeling, flaking, delaminating) will need to be stabilized by a licensed lead abatement contractor. All paint stabilization must be performed by a CDPH licensed lead abatement contractor using workers that have undergone the necessary lead training and are CDPH certified workers.

All fluorescent light fixture ballasts which are not clearly marked “No PCBs” or “PCB Free” shall be assumed to contain PCBs, and shall be removed intact, packaged, and disposed of appropriately. All other ballasts may be incinerated or recycled at an appropriate disposal site.

Smoke detectors that are to be demolished need to be disassembled and categorized as either ionization detector (radioactive) or photoelectric detectors, which can be completed by checking for the required radioactive sticker on the baseplate. Photoelectric detectors may be discarded as construction debris. Ionization detectors will require appropriate off-site disposal per appropriate regulations.

Aerosol cans of paint should be disposed of properly.

Closure

This report is for the sole benefit and exclusive use of San Bernardino City Unified School District (herein referred to as Client) in accordance with the terms and conditions attached to our proposal under which these services have been provided. Its preparation has been in accordance with generally accepted environmental practices. No other warranty, either express or implied, is made. The Scope of Services associated with the report was designed solely in accordance with the objectives, schedule, budget, and risk-management preferences of Client.



This letter report should not be regarded as a guarantee that no further asbestos-containing materials, beyond that which could be detected within the scope of this survey, is present at the Property. Converse makes no warranties or guarantees as to the accuracy or completeness of information provided or compiled by others. It is not possible to absolutely confirm that no asbestos-containing materials and/or hazardous substances exist at the Property. If none are identified as part of a limited scope of work, such a conclusion should not be construed as a guaranteed absence of such materials, but merely the results of the evaluation of the property at the time of the survey. Also, events may occur after the Property visit, which may result in contamination of the Property. Additional information, which was not found or available to Converse at the time of report preparation, may result in a modification of the conclusions and recommendations presented.

Any previously unsampled suspect materials should be considered positive for asbestos and/or lead until sampling occurs.

Any reliance on this report by Third Parties shall be at the Third Party's sole risk. Should San Bernardino City Unified School District wish to identify any additional relying parties not previously identified, a completed *Application of Authorization to Use* (see attachment) must be submitted to Converse Consultants.

We appreciate the opportunity to be of service to you. If you should have any questions or comments regarding these results, please contact either Laura Tanaka at 626-930-1261 or Norman Eke at (626) 930-1260.

Sincerely,

CONVERSE CONSULTANTS

Laura Tanaka, CAC
Principal Environmental Scientist

Norman S. Eke, CAC
Senior Vice President

Atch: Asbestos Analytical Report, Chain of Custody Documentation & Sample Location Map
Application for Authorization to Use



**Asbestos
Analytical Report,
Chain of Custody Documentation
& Sample Location Map**





LA Testing

4335 E. Airport Dr. Unit 110 Ontario, CA 91761

Tel/Fax: (909) 295-6825 / (909) 295-6826

<http://www.LATesting.com> / InlandEmpireLab@latesting.com

LA Testing Order: 712101107

Customer ID: 32CONV56

Customer PO: 181610604

Project ID:

Attention: George Paler
Converse Consultants
717 S Myrtle Avenue
Monrovia, CA 91016

Phone: (626) 930-1258

Fax: (626) 930-1212

Received Date: 06/21/2021 8:30 AM

Analysis Date: 06/21/2021

Collected Date: 06/18/2021

Project: 18-16-106-04

Test Report: Asbestos Analysis of Bulk Materials via EPA 600/R-93/116 Method using Polarized Light Microscopy

Sample	Description	Appearance	Non-Asbestos		Asbestos % Type
			% Fibrous	% Non-Fibrous	
SB-01-Roofing 1 <i>712101107-0001</i>	Bldg M1/M2, upper roof, SW - Roof core w/ gravel	Black Fibrous Homogeneous	15% Glass	85% Non-fibrous (Other)	None Detected
SB-01-Roofing 2 <i>712101107-0001A</i>	Bldg M1/M2, upper roof, SW - Roof core w/ gravel	Black Fibrous Homogeneous	15% Glass	85% Non-fibrous (Other)	None Detected
SB-01-Roofing 3 <i>712101107-0001B</i>	Bldg M1/M2, upper roof, SW - Roof core w/ gravel	Black Fibrous Homogeneous	15% Glass	85% Non-fibrous (Other)	None Detected
SB-01-Roofing 4 <i>712101107-0001C</i>	Bldg M1/M2, upper roof, SW - Roof core w/ gravel	Black Fibrous Homogeneous	3% Cellulose 10% Glass	87% Non-fibrous (Other)	None Detected
SB-01-Roofing 5 <i>712101107-0001D</i>	Bldg M1/M2, upper roof, SW - Roof core w/ gravel	Black Fibrous Homogeneous	15% Cellulose	85% Non-fibrous (Other)	None Detected
SB-01-Tar <i>712101107-0001E</i>	Bldg M1/M2, upper roof, SW - Roof core w/ gravel	Black Non-Fibrous Homogeneous		100% Non-fibrous (Other)	None Detected
SB-02-Roofing 1 <i>712101107-0002</i>	Bldg M1/M2, upper roof, center - Roof core w/ gravel	Black Fibrous Homogeneous	15% Glass	85% Non-fibrous (Other)	None Detected
SB-02-Roofing 2 <i>712101107-0002A</i>	Bldg M1/M2, upper roof, center - Roof core w/ gravel	Black Fibrous Homogeneous	15% Glass	85% Non-fibrous (Other)	None Detected
SB-02-Roofing 3 <i>712101107-0002B</i>	Bldg M1/M2, upper roof, center - Roof core w/ gravel	Black Fibrous Homogeneous	15% Glass	85% Non-fibrous (Other)	None Detected
SB-02-Roofing 4 <i>712101107-0002C</i>	Bldg M1/M2, upper roof, center - Roof core w/ gravel	Black Fibrous Homogeneous	3% Cellulose 10% Glass	87% Non-fibrous (Other)	None Detected
SB-02-Roofing 5 <i>712101107-0002D</i>	Bldg M1/M2, upper roof, center - Roof core w/ gravel	Black Fibrous Homogeneous	15% Cellulose	85% Non-fibrous (Other)	None Detected
SB-02-Tar <i>712101107-0002E</i>	Bldg M1/M2, upper roof, center - Roof core w/ gravel	Black Non-Fibrous Homogeneous		100% Non-fibrous (Other)	None Detected
SB-03-Roofing 1 <i>712101107-0003</i>	Bldg M1/M2, lower arcade, center - Roof core w/ gravel	Black Non-Fibrous Homogeneous	15% Glass	85% Non-fibrous (Other)	None Detected
SB-03-Roofing 2 <i>712101107-0003A</i>	Bldg M1/M2, lower arcade, center - Roof core w/ gravel	Black Non-Fibrous Homogeneous	15% Glass	85% Non-fibrous (Other)	None Detected
SB-03-Roofing 3 <i>712101107-0003B</i>	Bldg M1/M2, lower arcade, center - Roof core w/ gravel	Black Non-Fibrous Homogeneous	15% Glass	85% Non-fibrous (Other)	None Detected
SB-03-Roofing 4 <i>712101107-0003C</i>	Bldg M1/M2, lower arcade, center - Roof core w/ gravel	Black Non-Fibrous Homogeneous	15% Glass	85% Non-fibrous (Other)	None Detected

Initial report from: 06/21/2021 21:26:18



LA Testing

4335 E. Airport Dr. Unit 110 Ontario, CA 91761

Tel/Fax: (909) 295-6825 / (909) 295-6826

<http://www.LATesting.com> / InlandEmpireLab@latesting.com

LA Testing Order: 712101107

Customer ID: 32CONV56

Customer PO: 181610604

Project ID:

Test Report: Asbestos Analysis of Bulk Materials via EPA 600/R-93/116 Method using Polarized Light Microscopy

Sample	Description	Appearance	Non-Asbestos		Asbestos
			% Fibrous	% Non-Fibrous	% Type
SB-03-Tar <i>712101107-0003D</i>	Bldg M1/M2, lower arcade, center - Roof core w/ gravel	Black Non-Fibrous Homogeneous		100% Non-fibrous (Other)	None Detected
SB-04-Roofing 1 <i>712101107-0004</i>	Bldg M1/M2, upper roof, SW - Rolled roofing felt	Gray/Black Fibrous Heterogeneous	15% Glass	85% Non-fibrous (Other)	None Detected
SB-04-Roofing 2 <i>712101107-0004A</i>	Bldg M1/M2, upper roof, SW - Rolled roofing felt	Gray/Black Fibrous Heterogeneous	15% Glass	85% Non-fibrous (Other)	None Detected
SB-04-Roofing 3 <i>712101107-0004B</i>	Bldg M1/M2, upper roof, SW - Rolled roofing felt	Black Fibrous Homogeneous	15% Glass	85% Non-fibrous (Other)	None Detected
SB-04-Tar <i>712101107-0004C</i>	Bldg M1/M2, upper roof, SW - Rolled roofing felt	Black Non-Fibrous Homogeneous		100% Non-fibrous (Other)	None Detected
SB-05-Roofing 1 <i>712101107-0005</i>	Bldg M1/M2, upper roof, SE - Rolled roofing felt	Gray/Black Fibrous Heterogeneous	15% Glass	85% Non-fibrous (Other)	None Detected
SB-05-Roofing 2 <i>712101107-0005A</i>	Bldg M1/M2, upper roof, SE - Rolled roofing felt	Black Fibrous Homogeneous	15% Glass	85% Non-fibrous (Other)	None Detected
SB-05-Roofing 3 <i>712101107-0005B</i>	Bldg M1/M2, upper roof, SE - Rolled roofing felt	Black Fibrous Homogeneous	15% Glass	85% Non-fibrous (Other)	None Detected
SB-05-Roofing 4 <i>712101107-0005C</i>	Bldg M1/M2, upper roof, SE - Rolled roofing felt	Black Fibrous Homogeneous	10% Glass	90% Non-fibrous (Other)	None Detected
SB-05-Roofing 5 <i>712101107-0005D</i>	Bldg M1/M2, upper roof, SE - Rolled roofing felt	Black Fibrous Homogeneous	3% Cellulose 10% Glass	87% Non-fibrous (Other)	None Detected
SB-05-Tar <i>712101107-0005E</i>	Bldg M1/M2, upper roof, SE - Rolled roofing felt	Black Non-Fibrous Homogeneous		100% Non-fibrous (Other)	None Detected
SB-06-Roofing 1 <i>712101107-0006</i>	Bldg M1/M2, upper roof, N - Rolled roofing felt	Gray/Black Non-Fibrous Heterogeneous	15% Glass	85% Non-fibrous (Other)	None Detected
SB-06-Roofing 2 <i>712101107-0006A</i>	Bldg M1/M2, upper roof, N - Rolled roofing felt	Black Non-Fibrous Homogeneous	15% Glass	85% Non-fibrous (Other)	None Detected
SB-06-Roofing 3 <i>712101107-0006B</i>	Bldg M1/M2, upper roof, N - Rolled roofing felt	Black Non-Fibrous Homogeneous	15% Glass	85% Non-fibrous (Other)	None Detected
SB-06-Roofing 4 <i>712101107-0006C</i>	Bldg M1/M2, upper roof, N - Rolled roofing felt	Black Non-Fibrous Homogeneous	15% Glass	85% Non-fibrous (Other)	None Detected
SB-06-Roofing 5 <i>712101107-0006D</i>	Bldg M1/M2, upper roof, N - Rolled roofing felt	Black Non-Fibrous Homogeneous	20% Cellulose	80% Non-fibrous (Other)	None Detected
SB-06-Tar <i>712101107-0006E</i>	Bldg M1/M2, upper roof, N - Rolled roofing felt	Black Non-Fibrous Homogeneous		100% Non-fibrous (Other)	None Detected
SB-07-Roofing 1 <i>712101107-0007</i>	Bldg M3, roof, North - Roof core w/ gravel	Black Fibrous Homogeneous	15% Glass	85% Non-fibrous (Other)	None Detected
SB-07-Roofing 2 <i>712101107-0007A</i>	Bldg M3, roof, North - Roof core w/ gravel	Black Fibrous Homogeneous	15% Glass	85% Non-fibrous (Other)	None Detected

Initial report from: 06/21/2021 21:26:18



LA Testing

4335 E. Airport Dr. Unit 110 Ontario, CA 91761

Tel/Fax: (909) 295-6825 / (909) 295-6826

<http://www.LATesting.com> / InlandEmpireLab@latesting.com

LA Testing Order: 712101107

Customer ID: 32CONV56

Customer PO: 181610604

Project ID:

Test Report: Asbestos Analysis of Bulk Materials via EPA 600/R-93/116 Method using Polarized Light Microscopy

Sample	Description	Appearance	Non-Asbestos		Asbestos
			% Fibrous	% Non-Fibrous	% Type
SB-07-Roofing 3 <i>712101107-0007B</i>	Bldg M3, roof, North - Roof core w/ gravel	Black Fibrous Homogeneous	15% Glass	85% Non-fibrous (Other)	None Detected
SB-07-Tar <i>712101107-0007C</i>	Bldg M3, roof, North - Roof core w/ gravel	Black Non-Fibrous Homogeneous		100% Non-fibrous (Other)	None Detected
SB-08-Roofing 1 <i>712101107-0008</i>	Bldg M3, roof, center - Roof core w/ gravel	Black Fibrous Homogeneous	15% Glass	85% Non-fibrous (Other)	None Detected
SB-08-Roofing 2 <i>712101107-0008A</i>	Bldg M3, roof, center - Roof core w/ gravel	Black Fibrous Homogeneous	15% Glass	85% Non-fibrous (Other)	None Detected
SB-08-Roofing 3 <i>712101107-0008B</i>	Bldg M3, roof, center - Roof core w/ gravel	Black Fibrous Homogeneous	15% Glass	85% Non-fibrous (Other)	None Detected
SB-08-Roofing 4 <i>712101107-0008C</i>	Bldg M3, roof, center - Roof core w/ gravel	Black Fibrous Homogeneous	15% Glass	85% Non-fibrous (Other)	None Detected
SB-08-Tar <i>712101107-0008D</i>	Bldg M3, roof, center - Roof core w/ gravel	Black Non-Fibrous Homogeneous		100% Non-fibrous (Other)	None Detected
SB-09-Roofing 1 <i>712101107-0009</i>	Bldg M3, roof, South - Roof core w/ gravel	Black Fibrous Homogeneous	15% Glass	85% Non-fibrous (Other)	None Detected
SB-09-Roofing 2 <i>712101107-0009A</i>	Bldg M3, roof, South - Roof core w/ gravel	Black Fibrous Homogeneous	15% Glass	85% Non-fibrous (Other)	None Detected
SB-09-Roofing 3 <i>712101107-0009B</i>	Bldg M3, roof, South - Roof core w/ gravel	Black Fibrous Homogeneous	15% Glass	85% Non-fibrous (Other)	None Detected
SB-09-Roofing 4 <i>712101107-0009C</i>	Bldg M3, roof, South - Roof core w/ gravel	Black Fibrous Homogeneous	15% Glass	85% Non-fibrous (Other)	None Detected
SB-09-Roofing 5 <i>712101107-0009D</i>	Bldg M3, roof, South - Roof core w/ gravel	Black Fibrous Homogeneous	15% Glass	85% Non-fibrous (Other)	None Detected
SB-09-Tar <i>712101107-0009E</i>	Bldg M3, roof, South - Roof core w/ gravel	Black Non-Fibrous Homogeneous		100% Non-fibrous (Other)	None Detected
SB-10-Roofing 1 <i>712101107-0010</i>	Bldg M3, roof, SW - Rolled roof felt	Gray/Black Fibrous Heterogeneous	15% Synthetic	85% Non-fibrous (Other)	None Detected
SB-10-Roofing 2 <i>712101107-0010A</i>	Bldg M3, roof, SW - Rolled roof felt	Black Fibrous Homogeneous	15% Glass	85% Non-fibrous (Other)	None Detected
SB-10-Tar <i>712101107-0010B</i>	Bldg M3, roof, SW - Rolled roof felt	Black Non-Fibrous Homogeneous		100% Non-fibrous (Other)	None Detected
SB-11-Roofing 1 <i>712101107-0011</i>	Bldg M3, roof, East - Rolled roof felt	Gray/Black Fibrous Heterogeneous	15% Synthetic	85% Non-fibrous (Other)	None Detected
SB-11-Roofing 2 <i>712101107-0011A</i>	Bldg M3, roof, East - Rolled roof felt	Black Fibrous Homogeneous	15% Glass	85% Non-fibrous (Other)	None Detected
SB-11-Tar <i>712101107-0011B</i>	Bldg M3, roof, East - Rolled roof felt	Black Non-Fibrous Homogeneous		100% Non-fibrous (Other)	None Detected

Initial report from: 06/21/2021 21:26:18



LA Testing

4335 E. Airport Dr. Unit 110 Ontario, CA 91761

Tel/Fax: (909) 295-6825 / (909) 295-6826

<http://www.LATesting.com> / InlandEmpireLab@latesting.com

LA Testing Order: 712101107

Customer ID: 32CONV56

Customer PO: 181610604

Project ID:

Test Report: Asbestos Analysis of Bulk Materials via EPA 600/R-93/116 Method using Polarized Light Microscopy

Sample	Description	Appearance	Non-Asbestos		Asbestos
			% Fibrous	% Non-Fibrous	% Type
SB-12-Roofing 1 <i>712101107-0012</i>	Bldg M3, roof, NW - Rolled roof felt	Gray/Black Non-Fibrous Heterogeneous	15% Synthetic	85% Non-fibrous (Other)	None Detected
SB-12-Roofing 2 <i>712101107-0012A</i>	Bldg M3, roof, NW - Rolled roof felt	Black Non-Fibrous Homogeneous	15% Glass	85% Non-fibrous (Other)	None Detected
SB-12-Tar <i>712101107-0012B</i>	Bldg M3, roof, NW - Rolled roof felt	Black Non-Fibrous Homogeneous		100% Non-fibrous (Other)	None Detected
SB-13-Roofing 1 <i>712101107-0013</i>	Bldg M4, roof, SE - Roof core w/ gravel	Black Fibrous Homogeneous	15% Glass	85% Non-fibrous (Other)	None Detected
SB-13-Roofing 2 <i>712101107-0013A</i>	Bldg M4, roof, SE - Roof core w/ gravel	Black Fibrous Homogeneous	15% Glass	85% Non-fibrous (Other)	None Detected
SB-13-Roofing 3 <i>712101107-0013B</i>	Bldg M4, roof, SE - Roof core w/ gravel	Black Fibrous Homogeneous	15% Glass	85% Non-fibrous (Other)	None Detected
SB-13-Tar <i>712101107-0013C</i>	Bldg M4, roof, SE - Roof core w/ gravel	Black Non-Fibrous Homogeneous		100% Non-fibrous (Other)	None Detected
SB-14-Roofing 1 <i>712101107-0014</i>	Bldg M4, roof, center - Roof core w/ gravel	Black Fibrous Homogeneous	15% Glass	85% Non-fibrous (Other)	None Detected
SB-14-Roofing 2 <i>712101107-0014A</i>	Bldg M4, roof, center - Roof core w/ gravel	Black Fibrous Homogeneous	15% Glass	85% Non-fibrous (Other)	None Detected
SB-14-Roofing 3 <i>712101107-0014B</i>	Bldg M4, roof, center - Roof core w/ gravel	Black Fibrous Homogeneous	15% Glass	85% Non-fibrous (Other)	None Detected
SB-14-Tar <i>712101107-0014C</i>	Bldg M4, roof, center - Roof core w/ gravel	Black Non-Fibrous Homogeneous		100% Non-fibrous (Other)	None Detected
SB-15-Roofing 1 <i>712101107-0015</i>	Bldg M4, roof, SW - Roof core w/ gravel	Black Fibrous Homogeneous	15% Glass	85% Non-fibrous (Other)	None Detected
SB-15-Roofing 2 <i>712101107-0015A</i>	Bldg M4, roof, SW - Roof core w/ gravel	Black Fibrous Homogeneous	15% Glass	85% Non-fibrous (Other)	None Detected
SB-15-Roofing 3 <i>712101107-0015B</i>	Bldg M4, roof, SW - Roof core w/ gravel	Black Fibrous Homogeneous	15% Glass	85% Non-fibrous (Other)	None Detected
SB-15-Roofing 4 <i>712101107-0015C</i>	Bldg M4, roof, SW - Roof core w/ gravel	Black Fibrous Homogeneous	15% Glass	85% Non-fibrous (Other)	None Detected
SB-15-Tar <i>712101107-0015D</i>	Bldg M4, roof, SW - Roof core w/ gravel	Black Non-Fibrous Homogeneous		100% Non-fibrous (Other)	None Detected
SB-16-Roofing 1 <i>712101107-0016</i>	Bldg M4, roof, SE - Rolled roofing felt	Gray/Black Non-Fibrous Heterogeneous	10% Glass	90% Non-fibrous (Other)	None Detected
SB-16-Roofing 2 <i>712101107-0016A</i>	Bldg M4, roof, SE - Rolled roofing felt	Black Non-Fibrous Homogeneous	15% Glass	85% Non-fibrous (Other)	None Detected
SB-16-Roofing 3 <i>712101107-0016B</i>	Bldg M4, roof, SE - Rolled roofing felt	Black Non-Fibrous Homogeneous	15% Glass	85% Non-fibrous (Other)	None Detected

Initial report from: 06/21/2021 21:26:18



LA Testing

4335 E. Airport Dr. Unit 110 Ontario, CA 91761

Tel/Fax: (909) 295-6825 / (909) 295-6826

<http://www.LATesting.com> / InlandEmpireLab@latesting.com

LA Testing Order: 712101107

Customer ID: 32CONV56

Customer PO: 181610604

Project ID:

Test Report: Asbestos Analysis of Bulk Materials via EPA 600/R-93/116 Method using Polarized Light Microscopy

Sample	Description	Appearance	Non-Asbestos		Asbestos
			% Fibrous	% Non-Fibrous	% Type
SB-16-Tar <i>712101107-0016C</i>	Bldg M4, roof, SE - Rolled roofing felt	Black Non-Fibrous Homogeneous		100% Non-fibrous (Other)	None Detected
SB-17-Roofing 1 <i>712101107-0017</i>	Bldg M4, roof, center - Rolled roofing felt	Gray/Black Non-Fibrous Homogeneous	5% Synthetic 10% Glass	85% Non-fibrous (Other)	None Detected
SB-17-Roofing 2 <i>712101107-0017A</i>	Bldg M4, roof, center - Rolled roofing felt	Black Non-Fibrous Homogeneous	15% Glass	85% Non-fibrous (Other)	None Detected
SB-17-Roofing 3 <i>712101107-0017B</i>	Bldg M4, roof, center - Rolled roofing felt	Black Non-Fibrous Homogeneous	15% Glass	85% Non-fibrous (Other)	None Detected
SB-17-Roofing 4 <i>712101107-0017C</i>	Bldg M4, roof, center - Rolled roofing felt	Black Non-Fibrous Homogeneous	15% Glass	85% Non-fibrous (Other)	None Detected
SB-17-Roofing 5 <i>712101107-0017D</i>	Bldg M4, roof, center - Rolled roofing felt	Black Non-Fibrous Homogeneous	15% Glass	85% Non-fibrous (Other)	None Detected
SB-17-Tar <i>712101107-0017E</i>	Bldg M4, roof, center - Rolled roofing felt	Black Non-Fibrous Homogeneous		100% Non-fibrous (Other)	None Detected
SB-18-Roofing 1 <i>712101107-0018</i>	Bldg M4, roof, SW - Rolled roofing felt	Gray/Black Fibrous Heterogeneous	15% Glass	85% Non-fibrous (Other)	None Detected
SB-18-Roofing 2 <i>712101107-0018A</i>	Bldg M4, roof, SW - Rolled roofing felt	Black Fibrous Homogeneous	15% Glass	85% Non-fibrous (Other)	None Detected
SB-18-Roofing 3 <i>712101107-0018B</i>	Bldg M4, roof, SW - Rolled roofing felt	Black Fibrous Homogeneous	15% Glass	85% Non-fibrous (Other)	None Detected
SB-18-Tar <i>712101107-0018C</i>	Bldg M4, roof, SW - Rolled roofing felt	Black Non-Fibrous Homogeneous		100% Non-fibrous (Other)	None Detected
SB-19-Finish Coat <i>712101107-0019</i>	Bldg M4, exterior, West, center - Stucco	Tan Non-Fibrous Homogeneous		100% Non-fibrous (Other)	<1% Chrysotile
SB-19-Base Coat <i>712101107-0019A</i>	Bldg M4, exterior, West, center - Stucco	Gray Non-Fibrous Homogeneous		100% Non-fibrous (Other)	None Detected
SB-20 <i>712101107-0020</i>	Bldg M4, exterior, South, West - Stucco	Gray Non-Fibrous Homogeneous		100% Non-fibrous (Other)	None Detected
SB-21 <i>712101107-0021</i>	Bldg M4, exterior, North, West - Stucco	Gray Non-Fibrous Homogeneous		100% Non-fibrous (Other)	None Detected
SB-22 <i>712101107-0022</i>	Room M4A, North, West - Wall board mastic	White Non-Fibrous Homogeneous		100% Non-fibrous (Other)	None Detected
SB-23 <i>712101107-0023</i>	Room M4A, North, West - Wall board mastic	White Non-Fibrous Homogeneous		100% Non-fibrous (Other)	None Detected
SB-24 <i>712101107-0024</i>	Room M4A, North, West - Wall board mastic	White Non-Fibrous Homogeneous		100% Non-fibrous (Other)	None Detected

Initial report from: 06/21/2021 21:26:18



LA Testing

4335 E. Airport Dr. Unit 110 Ontario, CA 91761

Tel/Fax: (909) 295-6825 / (909) 295-6826

<http://www.LATesting.com> / InlandEmpireLab@lateesting.com

LA Testing Order: 712101107

Customer ID: 32CONV56

Customer PO: 181610604

Project ID:

Analyst(s)

Andrea Pedraza (45)

Humberto Espinoza (46)

Carolynn Tom, Laboratory Manager
or Other Approved Signatory

LA Testing maintains liability limited to cost of analysis. Interpretation and use of test results are the responsibility of the client. This report relates only to the samples reported above, and may not be reproduced, except in full, without written approval by LA Testing. LA Testing bears no responsibility for sample collection activities or analytical method limitations. The report reflects the samples as received. Results are generated from the field sampling data (sampling volumes and areas, locations, etc.) provided by the client on the Chain of Custody. Samples are within quality control criteria and met method specifications unless otherwise noted. The above analyses were performed in general compliance with Appendix E to Subpart E of 40 CFR (previously EPA 600/M4-82-020 "Interim Method") but augmented with procedures outlined in the 1993 ("final") version of the method. This report must not be used by the client to claim product certification, approval, or endorsement by NVLAP, NIST or any agency of the federal government. Non-friable organically bound materials present a problem matrix and therefore LA Testing recommends gravimetric reduction prior to analysis. Unless requested by the client, building materials manufactured with multiple layers (i.e. linoleum, wallboard, etc.) are reported as a single sample. Estimation of uncertainty is available on request.

Samples analyzed by LA Testing Ontario, CA NVLAP Lab Code 600239-0; CA ELAP 3053

Initial report from: 06/21/2021 21:26:18



Asbestos Chain of Custody

LA Testing Order Number (Lab Use Only):

#712101107

LA TESTING
520 MISSION STREET
S. PASADENA, CA 91030
PHONE: (323) 254-9960
FAX: (323) 254-9982

Company : Converse Consultants		LA Testing-Bill to: <input checked="" type="checkbox"/> Same <input type="checkbox"/> Different <small>If Bill to is Different note instructions in Comments**</small>	
Street: 717 S. Myrtle Avenue		<i>Third Party Billing requires written authorization from third party</i>	
City: Monrovia	State/Province: CA	Zip/Postal Code: 91016	Country: USA
Report To (Name): George Paler		Fax #:	
Telephone #: (626) 807-3416		Email Address: Itanaka@converseconsultants.com	
Project Name/Number: 18-16-106-04			
Please Provide Results: <input type="checkbox"/> Fax <input checked="" type="checkbox"/> Email		Purchase Order: 181610604	U.S. State Samples Taken: CA

Turnaround Time (TAT) Options* - Please Check

3 Hour
 6 Hour
 24 Hour
 48 Hour
 72 Hour
 96 Hour
 1 Week
 2 Week

*For TEM Air 3 hours through 6 hours, please call ahead to schedule. *There is a premium charge for 3 Hour TEM AHERA or EPA Level II TAT. You will be asked to sign an authorization form for this service. Analysis completed in accordance with LA Testing's Terms and Conditions located in the Analytical Price Guide.

PCM - Air <input type="checkbox"/> NIOSH 7400 <input type="checkbox"/> w/ OSHA 8hr. TWA PLM - Bulk (reporting limit) <input checked="" type="checkbox"/> PLM EPA 600/R-93/116 (<1%) <input type="checkbox"/> PLM EPA NOB (<1%) Point Count <input type="checkbox"/> 400 (<0.25%) <input type="checkbox"/> 1000 (<0.1%) Point Count w/Gravimetric <input type="checkbox"/> 400 (<0.25%) <input type="checkbox"/> 1000 (<0.1%) <input type="checkbox"/> NYS 198.1 (friable in NY) <input type="checkbox"/> NYS 198.6 NOB (non-friable-NY) <input type="checkbox"/> NIOSH 9002 (<1%)	TEM - Air <input type="checkbox"/> 4-4.5hr TAT (AHERA only) <input type="checkbox"/> AHERA 40 CFR, Part 763 <input type="checkbox"/> NIOSH 7402 <input type="checkbox"/> EPA Level II <input type="checkbox"/> ISO 10312 TEM - Bulk <input type="checkbox"/> TEM EPA NOB <input type="checkbox"/> NYS NOB 198.4 (non-friable-NY) <input type="checkbox"/> Chatfield SOP <input type="checkbox"/> TEM Mass Analysis-EPA 600 sec. 2.5 TEM - Water: EPA 100.2 Fibers >10µm <input type="checkbox"/> Waste <input type="checkbox"/> Drinking All Fiber Sizes <input type="checkbox"/> Waste <input type="checkbox"/> Drinking	TEM- Dust <input type="checkbox"/> Microvac - ASTM D 5755 <input type="checkbox"/> Wipe - ASTM D6480 <input type="checkbox"/> Carpet Sonication (EPA 600/J-93/167) Soil/Rock/Vermiculite <input type="checkbox"/> PLM CARB 435 - A (0.25% sensitivity) <input type="checkbox"/> PLM CARB 435 - B (0.1% sensitivity) <input type="checkbox"/> TEM CARB 435 - B (0.1% sensitivity) <input type="checkbox"/> TEM CARB 435 - C (0.01% sensitivity) <input type="checkbox"/> EPA Protocol (Semi-Quantitative) <input type="checkbox"/> EPA Protocol (Quantitative) Other: <input type="checkbox"/>
---	--	--

Check For Positive Stop - Clearly Identify Homogenous Group

Samplers Name: Rodney Stansfield **Samplers Signature:** Rodney Stansfield

Sample #	Sample Description	Volume/Area (Air) HA # (Bulk)	Date/Time Sampled
	<u>see Attached</u>	<u>See Attached</u>	<u>06/18/21</u>

Client Sample # (s): _____ **Total # of Samples:** _____

Relinquished (Client): ASCPB **Date:** 06/18/21 **Time:** 1655

Received (Lab): ASCPB **Date:** 6/21/2021 **Time:** 8:30AM

Comments/Special Instructions: Stuzco-1000-PT Count if result is ACCM.



Converse Consultants

#712101107

717 S. Myrtle Avenue
 Monrovia, CA 91016-3422
 Tel.: (626) 930-1200
 Fax: (626) 930-1212

BULK SAMPLE LOG

Project Name: SBHS M1-M4 Supplemental

Collected By: RDS

Project No.: 18-16-106-04

Date: 06/18/21

HOMOGENEOUS MATERIAL: Roof core w/Gravel

Sample Number	Location	Area Sq. Ft.	Condition
SB-01	Bldg M1/M2, upper Roof, SW	4,500	Good
SB-02	↓ , ↓ , Center	↓	↓
SB-03	↓ , Lower Arcade, center	↓	↓

Friability:
Potential for Contact with Material:
Influence of Vibration:
Potential for Air Erosion:
Damage Assessment:

Friable
 High
 High
 High
 Good

~~Non-Friable~~
 Moderate
 Moderate
 Moderate
 Damaged

Low
 Low
 Low
 Significantly Damaged

COMMENTS: Substrate is wood

CHAIN OF CUSTODY

Relinquished By: Paul Stanfield
 Received By: _____
 Relinquished By: _____
 Received By: _____

Time: 1655 Date: 06/18/21
 Time: _____ Date: _____
 Time: _____ Date: _____
 Time: _____ Date: _____



Converse Consultants

#712101107

717 S. Myrtle Avenue
 Monrovia, CA 91016-3422
 Tel.: (626) 930-1200
 Fax: (626) 930-1212

BULK SAMPLE LOG

Project Name: SBHS M1-M4 Supplemental

Collected By: RDS

Project No.: 18-16-106-04

Date: 06/18/21

HOMOGENEOUS MATERIAL: Rolled Roofing Felt

Sample Number	Location	Area Sq. Ft.	Condition
SB-04	Bldg M1/M2, Upper Roof, SW	540	Good
SB-05	↓ , ↓ , SE	↓	↓
SB-06	↓ , ↓ , N	↓	↓

Friability:
Potential for Contact with Material:
Influence of Vibration:
Potential for Air Erosion:
Damage Assessment:

Friable
 High
 High
 High
 Good

~~Non-Friable~~
~~Moderate~~
 Moderate
 Moderate
 Damaged

Low
 Low
 Low
 Significantly Damaged

COMMENTS: Parapets, and beneath HVAC equipment
Also east edge of arcade roof,
Substrate is wood

CHAIN OF CUSTODY

Relinquished By: Rol Stanfield
 Received By: _____
 Relinquished By: _____
 Received By: _____

Time: 1655
 Time: _____
 Time: _____
 Time: _____

Date: 06/18/21
 Date: _____
 Date: _____
 Date: _____



Converse Consultants

#712101107

717 S. Myrtle Avenue
Monrovia, CA 91016-3422
Tel.: (626) 930-1200
Fax: (626) 930-1212

BULK SAMPLE LOG

Project Name: SBHS M1-M4 Supplemental

Collected By: RDS

Project No.: 18-16-106-04

Date: 06/18/21

HOMOGENEOUS MATERIAL: Roof Core w/Gravel

Sample Number	Location	Area Sq. Ft.	Condition
SB-07	Bldg, M3, Roof, North	3,080	Good
SB-08	, , Center	↓	↓
SB-09	↓ , ↓, South	↓	↓

Friability:
Potential for Contact with Material:
Influence of Vibration:
Potential for Air Erosion:
Damage Assessment:

Friable
High
High
High
Good

~~Non-Friable~~
Moderate
Moderate
Moderate
Damaged

Low
Low
Low
Significantly Damaged

COMMENTS: Substrate is wood

CHAIN OF CUSTODY

Relinquished By: Rod Stanfield

Received By: _____

Relinquished By: _____

Received By: _____

Time: 1655 Date: 06/18/21

Time: _____ Date: _____

Time: _____ Date: _____

Time: _____ Date: _____



Converse Consultants

#712101107

717 S. Myrtle Avenue
Monrovia, CA 91016-3422
Tel.: (626) 930-1200
Fax: (626) 930-1212

BULK SAMPLE LOG

Project Name: SBHS M1-M4 Supplemental

Collected By: RDS

Project No.: 18-16-106-04

Date: 06/18/21

HOMOGENEOUS MATERIAL: Rolled Roof Felt

Sample Number	Location	Area Sq. Ft.	Condition
SB-10	Bldg M3, Roof, SW	340	Good
SB-11	↓, ↓, East	↓	↓
SB-12	↓, ↓, NW	↓	↓

Friability:
Potential for Contact with Material:
Influence of Vibration:
Potential for Air Erosion:
Damage Assessment:

Friable
High
High
High
Good

Non-Friable
Moderate
Moderate
Moderate
Damaged

Low
Low
Low
Significantly Damaged

COMMENTS:

on parapet (edges).
substrate is wood.

CHAIN OF CUSTODY

Relinquished By: Paul Stearns
Received By: _____
Relinquished By: _____
Received By: _____

Time: 1655
Time: _____
Time: _____
Time: _____

Date: 06/18/21
Date: _____
Date: _____
Date: _____



Converse Consultants #712101107

717 S. Myrtle Avenue
 Monrovia, CA 91016-3422
 Tel.: (626) 930-1200
 Fax: (626) 930-1212

BULK SAMPLE LOG

Project Name: SBHS M1-M4 Supplemental Collected By: RDS

Project No.: 18-16-106-04 Date: 06/18/21

HOMOGENEOUS MATERIAL: Roof Core w/Gravel

Sample Number	Location	Area Sq. Ft.	Condition
SB-13	Bldg M4, Roof, SE	2740	Good
SB-14	↓ , ↓ , Center	↓	↓
SB-15	↓ , ↓ , NW	↓	↓

<i>Friability:</i>	Friable	Non-Friable	
<i>Potential for Contact with Material:</i>	High	Moderate	Low
<i>Influence of Vibration:</i>	High	Moderate	Low
<i>Potential for Air Erosion:</i>	High	Moderate	Low
<i>Damage Assessment:</i>	Good	Damaged	Significantly Damaged

COMMENTS: Substrate is wood

CHAIN OF CUSTODY

Relinquished By: Paul Stevens Time: 1655 Date: 06/18/21

Received By: _____ Time: _____ Date: _____

Relinquished By: _____ Time: _____ Date: _____

Received By: _____ Time: _____ Date: _____



Converse Consultants

#712101107

717 S. Myrtle Avenue
Monrovia, CA 91016-3422
Tel.: (626) 930-1200
Fax: (626) 930-1212

BULK SAMPLE LOG

Project Name: SBHS M1-M4 Supplemental

Collected By: RDS

Project No.: 18-16-106-04

Date: 06/18/21

HOMOGENEOUS MATERIAL: Rolled Roofing Felt

Sample Number	Location	Area Sq. Ft.	Condition
SB-16	Bldg M4, Roof, SE	340	Good
SB-17	↓, ↓, center	↓	↓
SB-18	↓, ↓, NW	↓	↓

<i>Friability:</i>	Friable	Non-Friable	
<i>Potential for Contact with Material:</i>	High	Moderate	Low
<i>Influence of Vibration:</i>	High	Moderate	Low
<i>Potential for Air Erosion:</i>	High	Moderate	Low
<i>Damage Assessment:</i>	Good	Damaged	Significantly Damaged

COMMENTS: on parapets, and under HVAC equipment
Substrate is wood.

CHAIN OF CUSTODY

Relinquished By: [Signature]

Received By: _____

Relinquished By: _____

Received By: _____

Time: 1655 Date: 06/18/21

Time: _____ Date: _____

Time: _____ Date: _____

Time: _____ Date: _____



Converse Consultants #712101107

717 S. Myrtle Avenue
Monrovia, CA 91016-3422
Tel.: (626) 930-1200
Fax: (626) 930-1212

BULK SAMPLE LOG

Project Name: SBHS M1-M4 Supplemental

Collected By: RDS

Project No.: 18-16-106-04

Date: 06/18/21

HOMOGENEOUS MATERIAL: Stucco

Sample Number	Location	Area Sq. Ft.	Condition
SB-19	Bldg M4, Exterior, West, Center	3480	Good
SB-20	↓ , ↓ , South, West	↓	↓
SB-21	↓ , ↓ , North, West	↓	↓

Friability:
Potential for Contact with Material:
Influence of Vibration:
Potential for Air Erosion:
Damage Assessment:

Friable
High
High
High
Good

~~Non-Friable~~
Moderate
Moderate
Moderate
Damaged

Low
Low
Low
Significantly Damaged

COMMENTS: Painted

CHAIN OF CUSTODY

Relinquished By: Paul Stanfield Time: 1655 Date: 06/18/21
 Received By: _____ Time: _____ Date: _____
 Relinquished By: _____ Time: _____ Date: _____
 Received By: _____ Time: _____ Date: _____



Converse Consultants #712101107

717 S. Myrtle Avenue
Monrovia, CA 91016-3422
Tel.: (626) 930-1200
Fax: (626) 930-1212

BULK SAMPLE LOG

Project Name: SBHS M1-M4 Supplemental

Collected By: RDS

Project No.: 18-16-106-04

Date: 06/18/21

HOMOGENEOUS MATERIAL: wall Board Mastic

Sample Number	Location	Area Sq. Ft.	Condition
SB-22	Room M4A, North, West	1400	Good
SB-23	↓	↓	↓
SB-24	↓	↓	↓

<i>Friability:</i>	Friable	Non-Friable	
<i>Potential for Contact with Material:</i>	High	Moderate	Low
<i>Influence of Vibration:</i>	High	Moderate	Low
<i>Potential for Air Erosion:</i>	High	Moderate	Low
<i>Damage Assessment:</i>	Good	Damaged	Significantly Damaged

COMMENTS: Behind Fiber wall Boards (cellulose)
Substrate is dry well.
In Room M4A and M4B

CHAIN OF CUSTODY

Relinquished By: <u>[Signature]</u>	Time: <u>1655</u>	Date: <u>06/18/21</u>
Received By: _____	Time: _____	Date: _____
Relinquished By: _____	Time: _____	Date: _____
Received By: _____	Time: _____	Date: _____



LA Testing

4335 E. Airport Dr. Unit 110 Ontario, CA 91761
Phone/Fax: (909) 295-6825 / (909) 295-6826
<http://www.LATesting.com> / InlandEmpireLab@latesting.com

LA Testing Order: 712101137
Customer ID: 32CONV56
Customer PO:
Project ID:

Attention: Laura Tanaka
Converse Consultants
717 S Myrtle Avenue
Monrovia, CA 91016
Phone: (626) 930-1260
Fax: (626) 930-1212
Received: 06/22/2021 3:00 PM
Analysis Date: 06/22/2021
Collected: 06/22/2021
Project: Ref-712101107 - 18-16-106-04

Test Report: Asbestos Analysis of Bulk Material via EPA 600/R-93/116. Quantitation using the 1,000 Point Count Procedure

Sample	Description	Appearance	Non-Asbestos		Asbestos
			% Fibrous	% Non-Fibrous	% Type
SB-19-Finish Coat 712101137-0001	Bldg M4, exterior, West, center - Stucco	Tan Non-Fibrous Homogeneous		100.0% Non-fibrous (Other)	<0.1% Chrysotile

Analyst(s)

Carolynn Tom (1)

Carolynn Tom, Laboratory Manager
or other approved signatory

LA Testing maintains liability limited to cost of analysis. Interpretation and use of test results are the responsibility of the client. This report relates only to the samples reported above, and may not be reproduced, except in full, without written approval by LA Testing. LA Testing bears no responsibility for sample collection activities or analytical method limitations. The report reflects the samples as received. Results are generated from the field sampling data (sampling volumes and areas, locations, etc.) provided by the client on the Chain of Custody. Samples are within quality control criteria and met method specifications unless otherwise noted. The above analyses were performed in general compliance with Appendix E to Subpart E of 40 CFR (previously EPA 600/M4-82-020 "Interim Method") but augmented with procedures outlined in the 1993 ("final") version of the method. This report must not be used by the client to claim product certification, approval, or endorsement by NVLAP, NIST or any agency of the federal government. Non-friable organically bound materials present a problem matrix and therefore LA Testing recommends gravimetric reduction prior to analysis. Unless requested by the client, building materials manufactured with multiple layers (i.e. linoleum, wallboard, etc.) are reported as a single sample. Estimation of uncertainty is available on request.

Samples analyzed by LA Testing Ontario, CA NVLAP Lab Code 600239-0; CA ELAP 3053

Initial report from: 06/22/2021 15:53:45

Solte, Ashley

From: Laura A. Tanaka <ltanaka@ConverseConsultants.com>
Sent: Tuesday, June 22, 2021 2:30 PM
To: Inland Empire
Cc: Looney, Tad; RDS (rodso64@hotmail.com)
Subject: FW: LA Testing report for order(s) 712101107 (712101107 - 18-16-106-04)
Attachments: 712101107_001.pdf

#712101137

Follow Up Flag: Follow up
Flag Status: Flagged

AP (email)
rec. 6/22/2021
@ 3:00PM

[EXTERNAL E-MAIL]

Please analyze Converse Sample SB-19 by 1000 point count.

SB-19-Finish Coat
712101107-0019
Tan 100% Non-fibrous (Other) <1% Chrysotile
Non-Fibrous
Homogeneous
Bldg M4, exterior,
West, center - Stucco

Need 24 hour TAT. Let me know if this TAT is possible or not.

Laura Tanaka
Converse Consultants

From: LA Testing (Ontario) <InlandEmpireLab@lateesting.com>
Sent: Monday, June 21, 2021 6:39 PM
To: Laura A. Tanaka <ltanaka@ConverseConsultants.com>
Subject: LA Testing report for order(s) 712101107 (712101107 - 18-16-106-04)

Report for order(s):
712101107 - 18-16-106-04



LA Testing | 4335 E Airport Dr. Unit 110 | Ontario, CA 91761
Phone: 909-295-6825 | Fax: | Toll Free:
Lab Hours:

Some of the resources LATesting, Inc. offers to our clients:
[LABConnect](#) | [Order Products](#) | [Client Corner](#) | [Training](#) | [Additional Resources](#) | [Sampling Videos](#)

"This email may contain privileged and confidential information and is solely for the use of the sender's intended recipient(s). **If you are not the intended recipient of this communication, you are hereby notified that any unauthorized review, use, dissemination, distribution, downloading, or copying of this communication is strictly prohibited.** If you received this email in error, please notify the sender by reply email and delete all copies and attachments. Thank you."



LA Testing

#712101137

4335 E. Airport Dr. Unit 110 Ontario, CA 91761

Tel/Fax: (909) 295-6825 / (909) 295-6826

http://www.LATesting.com / InlandEmpireLab@latesting.com

LA Testing Order: 712101107

Customer ID: 32CONV56

Customer PO: 181610604

Project ID:

Test Report: Asbestos Analysis of Bulk Materials via EPA 600/R-93/116 Method using Polarized Light Microscopy

Sample	Description	Appearance	Non-Asbestos		Asbestos
			% Fibrous	% Non-Fibrous	% Type
SB-12-Roofing 1 712101107-0012	Bldg M3, roof, NW - Rolled roof felt	Gray/Black Non-Fibrous Heterogeneous	15% Synthetic	85% Non-fibrous (Other)	None Detected
SB-12-Roofing 2 712101107-0012A	Bldg M3, roof, NW - Rolled roof felt	Black Non-Fibrous Homogeneous	15% Glass	85% Non-fibrous (Other)	None Detected
SB-12-Tar 712101107-0012B	Bldg M3, roof, NW - Rolled roof felt	Black Non-Fibrous Homogeneous		100% Non-fibrous (Other)	None Detected
SB-13-Roofing 1 712101107-0013	Bldg M4, roof, SE - Roof core w/ gravel	Black Fibrous Homogeneous	15% Glass	85% Non-fibrous (Other)	None Detected
SB-13-Roofing 2 712101107-0013A	Bldg M4, roof, SE - Roof core w/ gravel	Black Fibrous Homogeneous	15% Glass	85% Non-fibrous (Other)	None Detected
SB-13-Roofing 3 712101107-0013B	Bldg M4, roof, SE - Roof core w/ gravel	Black Fibrous Homogeneous	15% Glass	85% Non-fibrous (Other)	None Detected
SB-13-Tar 712101107-0013C	Bldg M4, roof, SE - Roof core w/ gravel	Black Non-Fibrous Homogeneous		100% Non-fibrous (Other)	None Detected
SB-14-Roofing 1 712101107-0014	Bldg M4, roof, center - Roof core w/ gravel	Black Fibrous Homogeneous	15% Glass	85% Non-fibrous (Other)	None Detected
SB-14-Roofing 2 712101107-0014A	Bldg M4, roof, center - Roof core w/ gravel	Black Fibrous Homogeneous	15% Glass	85% Non-fibrous (Other)	None Detected
SB-14-Roofing 3 712101107-0014B	Bldg M4, roof, center - Roof core w/ gravel	Black Fibrous Homogeneous	15% Glass	85% Non-fibrous (Other)	None Detected
SB-14-Tar 712101107-0014C	Bldg M4, roof, center - Roof core w/ gravel	Black Non-Fibrous Homogeneous		100% Non-fibrous (Other)	None Detected
SB-15-Roofing 1 712101107-0015	Bldg M4, roof, SW - Roof core w/ gravel	Black Fibrous Homogeneous	15% Glass	85% Non-fibrous (Other)	None Detected
SB-15-Roofing 2 712101107-0015A	Bldg M4, roof, SW - Roof core w/ gravel	Black Fibrous Homogeneous	15% Glass	85% Non-fibrous (Other)	None Detected
SB-15-Roofing 3 712101107-0015B	Bldg M4, roof, SW - Roof core w/ gravel	Black Fibrous Homogeneous	15% Glass	85% Non-fibrous (Other)	None Detected
SB-15-Roofing 4 712101107-0015C	Bldg M4, roof, SW - Roof core w/ gravel	Black Fibrous Homogeneous	15% Glass	85% Non-fibrous (Other)	None Detected
SB-15-Tar 712101107-0015D	Bldg M4, roof, SW - Roof core w/ gravel	Black Non-Fibrous Homogeneous		100% Non-fibrous (Other)	None Detected
SB-16-Roofing 1 712101107-0016	Bldg M4, roof, SE - Rolled roofing felt	Gray/Black Non-Fibrous Heterogeneous	10% Glass	90% Non-fibrous (Other)	None Detected
SB-16-Roofing 2 712101107-0016A	Bldg M4, roof, SE - Rolled roofing felt	Black Non-Fibrous Homogeneous	15% Glass	85% Non-fibrous (Other)	None Detected
SB-16-Roofing 3 712101107-0016B	Bldg M4, roof, SE - Rolled roofing felt	Black Non-Fibrous Homogeneous	15% Glass	85% Non-fibrous (Other)	None Detected

Initial report from: 06/21/2021 21:26:18



LA Testing

4335 E. Airport Dr. Unit 110 Ontario, CA 91761

Tel/Fax: (909) 295-6825 / (909) 295-6826

http://www.LATesting.com / InlandEmpireLab@latesting.com

LA Testing Order: 712101107

Customer ID: 32CONV56

Customer PO: 181610604

Project ID:

#712101137

Test Report: Asbestos Analysis of Bulk Materials via EPA 600/R-93/116 Method using Polarized Light Microscopy

Sample	Description	Appearance	Non-Asbestos		Asbestos
			% Fibrous	% Non-Fibrous	% Type
SB-07-Roofing 3 712101107-0007B	Bldg M3, roof, North - Roof core w/ gravel	Black Fibrous Homogeneous	15% Glass	85% Non-fibrous (Other)	None Detected
SB-07-Tar 712101107-0007C	Bldg M3, roof, North - Roof core w/ gravel	Black Non-Fibrous Homogeneous		100% Non-fibrous (Other)	None Detected
SB-08-Roofing 1 712101107-0008	Bldg M3, roof, center - Roof core w/ gravel	Black Fibrous Homogeneous	15% Glass	85% Non-fibrous (Other)	None Detected
SB-08-Roofing 2 712101107-0008A	Bldg M3, roof, center - Roof core w/ gravel	Black Fibrous Homogeneous	15% Glass	85% Non-fibrous (Other)	None Detected
SB-08-Roofing 3 712101107-0008B	Bldg M3, roof, center - Roof core w/ gravel	Black Fibrous Homogeneous	15% Glass	85% Non-fibrous (Other)	None Detected
SB-08-Roofing 4 712101107-0008C	Bldg M3, roof, center - Roof core w/ gravel	Black Fibrous Homogeneous	15% Glass	85% Non-fibrous (Other)	None Detected
SB-08-Tar 712101107-0008D	Bldg M3, roof, center - Roof core w/ gravel	Black Non-Fibrous Homogeneous		100% Non-fibrous (Other)	None Detected
SB-09-Roofing 1 712101107-0009	Bldg M3, roof, South - Roof core w/ gravel	Black Fibrous Homogeneous	15% Glass	85% Non-fibrous (Other)	None Detected
SB-09-Roofing 2 712101107-0009A	Bldg M3, roof, South - Roof core w/ gravel	Black Fibrous Homogeneous	15% Glass	85% Non-fibrous (Other)	None Detected
SB-09-Roofing 3 712101107-0009B	Bldg M3, roof, South - Roof core w/ gravel	Black Fibrous Homogeneous	15% Glass	85% Non-fibrous (Other)	None Detected
SB-09-Roofing 4 712101107-0009C	Bldg M3, roof, South - Roof core w/ gravel	Black Fibrous Homogeneous	15% Glass	85% Non-fibrous (Other)	None Detected
SB-09-Roofing 5 712101107-0009D	Bldg M3, roof, South - Roof core w/ gravel	Black Fibrous Homogeneous	15% Glass	85% Non-fibrous (Other)	None Detected
SB-09-Tar 712101107-0009E	Bldg M3, roof, South - Roof core w/ gravel	Black Non-Fibrous Homogeneous		100% Non-fibrous (Other)	None Detected
SB-10-Roofing 1 712101107-0010	Bldg M3, roof, SW - Rolled roof felt	Gray/Black Fibrous Heterogeneous	15% Synthetic	85% Non-fibrous (Other)	None Detected
SB-10-Roofing 2 712101107-0010A	Bldg M3, roof, SW - Rolled roof felt	Black Fibrous Homogeneous	15% Glass	85% Non-fibrous (Other)	None Detected
SB-10-Tar 712101107-0010B	Bldg M3, roof, SW - Rolled roof felt	Black Non-Fibrous Homogeneous		100% Non-fibrous (Other)	None Detected
SB-11-Roofing 1 712101107-0011	Bldg M3, roof, East - Rolled roof felt	Gray/Black Fibrous Heterogeneous	15% Synthetic	85% Non-fibrous (Other)	None Detected
SB-11-Roofing 2 712101107-0011A	Bldg M3, roof, East - Rolled roof felt	Black Fibrous Homogeneous	15% Glass	85% Non-fibrous (Other)	None Detected
SB-11-Tar 712101107-0011B	Bldg M3, roof, East - Rolled roof felt	Black Non-Fibrous Homogeneous		100% Non-fibrous (Other)	None Detected

Initial report from: 06/21/2021 21:26:18

LA Testing
#712101137

4335 E. Airport Dr. Unit 110 Ontario, CA 91761

Tel/Fax: (909) 295-6825 / (909) 295-6826

http://www.LATesting.com / InlandEmpireLab@latesting.com

LA Testing Order: 712101107

Customer ID: 32CONV56

Customer PO: 181610604

Project ID:

Test Report: Asbestos Analysis of Bulk Materials via EPA 600/R-93/116 Method using Polarized Light Microscopy

Sample	Description	Appearance	Non-Asbestos		Asbestos
			% Fibrous	% Non-Fibrous	% Type
SB-03-Tar 712101107-0003D	Bldg M1/M2, lower arcade, center - Roof core w/ gravel	Black Non-Fibrous Homogeneous		100% Non-fibrous (Other)	None Detected
SB-04-Roofing 1 712101107-0004	Bldg M1/M2, upper roof, SW - Rolled roofing felt	Gray/Black Fibrous Heterogeneous	15% Glass	85% Non-fibrous (Other)	None Detected
SB-04-Roofing 2 712101107-0004A	Bldg M1/M2, upper roof, SW - Rolled roofing felt	Gray/Black Fibrous Heterogeneous	15% Glass	85% Non-fibrous (Other)	None Detected
SB-04-Roofing 3 712101107-0004B	Bldg M1/M2, upper roof, SW - Rolled roofing felt	Black Fibrous Homogeneous	15% Glass	85% Non-fibrous (Other)	None Detected
SB-04-Tar 712101107-0004C	Bldg M1/M2, upper roof, SW - Rolled roofing felt	Black Non-Fibrous Homogeneous		100% Non-fibrous (Other)	None Detected
SB-05-Roofing 1 712101107-0005	Bldg M1/M2, upper roof, SE - Rolled roofing felt	Gray/Black Fibrous Heterogeneous	15% Glass	85% Non-fibrous (Other)	None Detected
SB-05-Roofing 2 712101107-0005A	Bldg M1/M2, upper roof, SE - Rolled roofing felt	Black Fibrous Homogeneous	15% Glass	85% Non-fibrous (Other)	None Detected
SB-05-Roofing 3 712101107-0005B	Bldg M1/M2, upper roof, SE - Rolled roofing felt	Black Fibrous Homogeneous	15% Glass	85% Non-fibrous (Other)	None Detected
SB-05-Roofing 4 712101107-0005C	Bldg M1/M2, upper roof, SE - Rolled roofing felt	Black Fibrous Homogeneous	10% Glass	90% Non-fibrous (Other)	None Detected
SB-05-Roofing 5 712101107-0005D	Bldg M1/M2, upper roof, SE - Rolled roofing felt	Black Fibrous Homogeneous	3% Cellulose 10% Glass	87% Non-fibrous (Other)	None Detected
SB-05-Tar 712101107-0005E	Bldg M1/M2, upper roof, SE - Rolled roofing felt	Black Non-Fibrous Homogeneous		100% Non-fibrous (Other)	None Detected
SB-06-Roofing 1 712101107-0006	Bldg M1/M2, upper roof, N - Rolled roofing felt	Gray/Black Non-Fibrous Heterogeneous	15% Glass	85% Non-fibrous (Other)	None Detected
SB-06-Roofing 2 712101107-0006A	Bldg M1/M2, upper roof, N - Rolled roofing felt	Black Non-Fibrous Homogeneous	15% Glass	85% Non-fibrous (Other)	None Detected
SB-06-Roofing 3 712101107-0006B	Bldg M1/M2, upper roof, N - Rolled roofing felt	Black Non-Fibrous Homogeneous	15% Glass	85% Non-fibrous (Other)	None Detected
SB-06-Roofing 4 712101107-0006C	Bldg M1/M2, upper roof, N - Rolled roofing felt	Black Non-Fibrous Homogeneous	15% Glass	85% Non-fibrous (Other)	None Detected
SB-06-Roofing 5 712101107-0006D	Bldg M1/M2, upper roof, N - Rolled roofing felt	Black Non-Fibrous Homogeneous	20% Cellulose	80% Non-fibrous (Other)	None Detected
SB-06-Tar 712101107-0006E	Bldg M1/M2, upper roof, N - Rolled roofing felt	Black Non-Fibrous Homogeneous		100% Non-fibrous (Other)	None Detected
SB-07-Roofing 1 712101107-0007	Bldg M3, roof, North - Roof core w/ gravel	Black Fibrous Homogeneous	15% Glass	85% Non-fibrous (Other)	None Detected
SB-07-Roofing 2 712101107-0007A	Bldg M3, roof, North - Roof core w/ gravel	Black Fibrous Homogeneous	15% Glass	85% Non-fibrous (Other)	None Detected

Initial report from: 06/21/2021 21:26:18



LA Testing

4335 E. Airport Dr. Unit 110 Ontario, CA 91761

Tel/Fax: (909) 295-6825 / (909) 295-6826

http://www.LATesting.com / InlandEmpireLab@latesting.com

#712101137

LA Testing Order: 712101107
Customer ID: 32CONV56
Customer PO: 181610604
Project ID:

Attention: George Paler
 Converse Consultants
 717 S Myrtle Avenue
 Monrovia, CA 91016

Phone: (626) 930-1258
Fax: (626) 930-1212
Received Date: 06/21/2021 8:30 AM
Analysis Date: 06/21/2021
Collected Date: 06/18/2021

Project: 18-16-106-04

Test Report: Asbestos Analysis of Bulk Materials via EPA 600/R-93/116 Method using Polarized Light Microscopy

Sample	Description	Appearance	Non-Asbestos		Asbestos
			% Fibrous	% Non-Fibrous	% Type
SB-01-Roofing 1 712101107-0001	Bldg M1/M2, upper roof, SW - Roof core w/ gravel	Black Fibrous Homogeneous	15% Glass	85% Non-fibrous (Other)	None Detected
SB-01-Roofing 2 712101107-0001A	Bldg M1/M2, upper roof, SW - Roof core w/ gravel	Black Fibrous Homogeneous	15% Glass	85% Non-fibrous (Other)	None Detected
SB-01-Roofing 3 712101107-0001B	Bldg M1/M2, upper roof, SW - Roof core w/ gravel	Black Fibrous Homogeneous	15% Glass	85% Non-fibrous (Other)	None Detected
SB-01-Roofing 4 712101107-0001C	Bldg M1/M2, upper roof, SW - Roof core w/ gravel	Black Fibrous Homogeneous	3% Cellulose 10% Glass	87% Non-fibrous (Other)	None Detected
SB-01-Roofing 5 712101107-0001D	Bldg M1/M2, upper roof, SW - Roof core w/ gravel	Black Fibrous Homogeneous	15% Cellulose	85% Non-fibrous (Other)	None Detected
SB-01-Tar 712101107-0001E	Bldg M1/M2, upper roof, SW - Roof core w/ gravel	Black Non-Fibrous Homogeneous		100% Non-fibrous (Other)	None Detected
SB-02-Roofing 1 712101107-0002	Bldg M1/M2, upper roof, center - Roof core w/ gravel	Black Fibrous Homogeneous	15% Glass	85% Non-fibrous (Other)	None Detected
SB-02-Roofing 2 712101107-0002A	Bldg M1/M2, upper roof, center - Roof core w/ gravel	Black Fibrous Homogeneous	15% Glass	85% Non-fibrous (Other)	None Detected
SB-02-Roofing 3 712101107-0002B	Bldg M1/M2, upper roof, center - Roof core w/ gravel	Black Fibrous Homogeneous	15% Glass	85% Non-fibrous (Other)	None Detected
SB-02-Roofing 4 712101107-0002C	Bldg M1/M2, upper roof, center - Roof core w/ gravel	Black Fibrous Homogeneous	3% Cellulose 10% Glass	87% Non-fibrous (Other)	None Detected
SB-02-Roofing 5 712101107-0002D	Bldg M1/M2, upper roof, center - Roof core w/ gravel	Black Fibrous Homogeneous	15% Cellulose	85% Non-fibrous (Other)	None Detected
SB-02-Tar 712101107-0002E	Bldg M1/M2, upper roof, center - Roof core w/ gravel	Black Non-Fibrous Homogeneous		100% Non-fibrous (Other)	None Detected
SB-03-Roofing 1 712101107-0003	Bldg M1/M2, lower arcade, center - Roof core w/ gravel	Black Non-Fibrous Homogeneous	15% Glass	85% Non-fibrous (Other)	None Detected
SB-03-Roofing 2 712101107-0003A	Bldg M1/M2, lower arcade, center - Roof core w/ gravel	Black Non-Fibrous Homogeneous	15% Glass	85% Non-fibrous (Other)	None Detected
SB-03-Roofing 3 712101107-0003B	Bldg M1/M2, lower arcade, center - Roof core w/ gravel	Black Non-Fibrous Homogeneous	15% Glass	85% Non-fibrous (Other)	None Detected
SB-03-Roofing 4 712101107-0003C	Bldg M1/M2, lower arcade, center - Roof core w/ gravel	Black Non-Fibrous Homogeneous	15% Glass	85% Non-fibrous (Other)	None Detected

Initial report from: 06/21/2021 21:26:18



LA Testing

4335 E. Airport Dr. Unit 110 Ontario, CA 91761
 Tel/Fax: (909) 295-6825 / (909) 295-6826
 http://www.LATesting.com / InlandEmpireLab@latesting.com

#712101137

LA Testing Order: 712101107
 Customer ID: 32CONV56
 Customer PO: 181610604
 Project ID:

Test Report: Asbestos Analysis of Bulk Materials via EPA 600/R-93/116 Method using Polarized Light Microscopy

Sample	Description	Appearance	Non-Asbestos		Asbestos
			% Fibrous	% Non-Fibrous	% Type
SB-16-Tar <small>712101107-0016C</small>	Bldg M4, roof, SE - Rolled roofing felt	Black Non-Fibrous Homogeneous		100% Non-fibrous (Other)	None Detected
SB-17-Roofing 1 <small>712101107-0017</small>	Bldg M4, roof, center - Rolled roofing felt	Gray/Black Non-Fibrous Homogeneous	5% Synthetic 10% Glass	85% Non-fibrous (Other)	None Detected
SB-17-Roofing 2 <small>712101107-0017A</small>	Bldg M4, roof, center - Rolled roofing felt	Black Non-Fibrous Homogeneous	15% Glass	85% Non-fibrous (Other)	None Detected
SB-17-Roofing 3 <small>712101107-0017B</small>	Bldg M4, roof, center - Rolled roofing felt	Black Non-Fibrous Homogeneous	15% Glass	85% Non-fibrous (Other)	None Detected
SB-17-Roofing 4 <small>712101107-0017C</small>	Bldg M4, roof, center - Rolled roofing felt	Black Non-Fibrous Homogeneous	15% Glass	85% Non-fibrous (Other)	None Detected
SB-17-Roofing 5 <small>712101107-0017D</small>	Bldg M4, roof, center - Rolled roofing felt	Black Non-Fibrous Homogeneous	15% Glass	85% Non-fibrous (Other)	None Detected
SB-17-Tar <small>712101107-0017E</small>	Bldg M4, roof, center - Rolled roofing felt	Black Non-Fibrous Homogeneous		100% Non-fibrous (Other)	None Detected
SB-18-Roofing 1 <small>712101107-0018</small>	Bldg M4, roof, SW - Rolled roofing felt	Gray/Black Fibrous Heterogeneous	15% Glass	85% Non-fibrous (Other)	None Detected
SB-18-Roofing 2 <small>712101107-0018A</small>	Bldg M4, roof, SW - Rolled roofing felt	Black Fibrous Homogeneous	15% Glass	85% Non-fibrous (Other)	None Detected
SB-18-Roofing 3 <small>712101107-0018B</small>	Bldg M4, roof, SW - Rolled roofing felt	Black Fibrous Homogeneous	15% Glass	85% Non-fibrous (Other)	None Detected
SB-18-Tar <small>712101107-0018C</small>	Bldg M4, roof, SW - Rolled roofing felt	Black Non-Fibrous Homogeneous		100% Non-fibrous (Other)	None Detected
SB-19-Finish Coat <small>712101107-0019</small>	Bldg M4, exterior, West, center - Stucco	Tan Non-Fibrous Homogeneous		100% Non-fibrous (Other)	<1% Chrysotile
SB-19-Base Coat <small>712101107-0019A</small>	Bldg M4, exterior, West, center - Stucco	Gray Non-Fibrous Homogeneous		100% Non-fibrous (Other)	None Detected
SB-20 <small>712101107-0020</small>	Bldg M4, exterior, South, West - Stucco	Gray Non-Fibrous Homogeneous		100% Non-fibrous (Other)	None Detected
SB-21 <small>712101107-0021</small>	Bldg M4, exterior, North, West - Stucco	Gray Non-Fibrous Homogeneous		100% Non-fibrous (Other)	None Detected
SB-22 <small>712101107-0022</small>	Room M4A, North, West - Wall board mastic	White Non-Fibrous Homogeneous		100% Non-fibrous (Other)	None Detected
SB-23 <small>712101107-0023</small>	Room M4A, North, West - Wall board mastic	White Non-Fibrous Homogeneous		100% Non-fibrous (Other)	None Detected
SB-24 <small>712101107-0024</small>	Room M4A, North, West - Wall board mastic	White Non-Fibrous Homogeneous		100% Non-fibrous (Other)	None Detected

Initial report from: 06/21/2021 21:26:18



LA Testing

4335 E. Airport Dr. Unit 110 Ontario, CA 91761
Tel/Fax: (909) 295-6825 / (909) 295-6826
<http://www.LATesting.com> / InlandEmpireLab@lateesting.com

#712101137

LA Testing Order: 712101107
Customer ID: 32CONV56
Customer PO: 181610604
Project ID:

Analyst(s)

Andrea Pedraza (45)

Humberto Espinoza (46)

Carolynn Tom, Laboratory Manager
or Other Approved Signatory

LA Testing maintains liability limited to cost of analysis. Interpretation and use of test results are the responsibility of the client. This report relates only to the samples reported above, and may not be reproduced, except in full, without written approval by LA Testing. LA Testing bears no responsibility for sample collection activities or analytical method limitations. The report reflects the samples as received. Results are generated from the field sampling data (sampling volumes and areas, locations, etc.) provided by the client on the Chain of Custody. Samples are within quality control criteria and met method specifications unless otherwise noted. The above analyses were performed in general compliance with Appendix E to Subpart E of 40 CFR (previously EPA 600/M4-82-020 "Interim Method") but augmented with procedures outlined in the 1993 ("final") version of the method. This report must not be used by the client to claim product certification, approval, or endorsement by NVLAP, NIST or any agency of the federal government. Non-friable organically bound materials present a problem matrix and therefore LA Testing recommends gravimetric reduction prior to analysis. Unless requested by the client, building materials manufactured with multiple layers (i.e. linoleum, wallboard, etc.) are reported as a single sample. Estimation of uncertainty is available on request.

Samples analyzed by LA Testing Ontario, CA NVLAP Lab Code 600239-0, CA ELAP 3053

Initial report from: 06/21/2021 21:26:18

N
(NOT TO Scale)

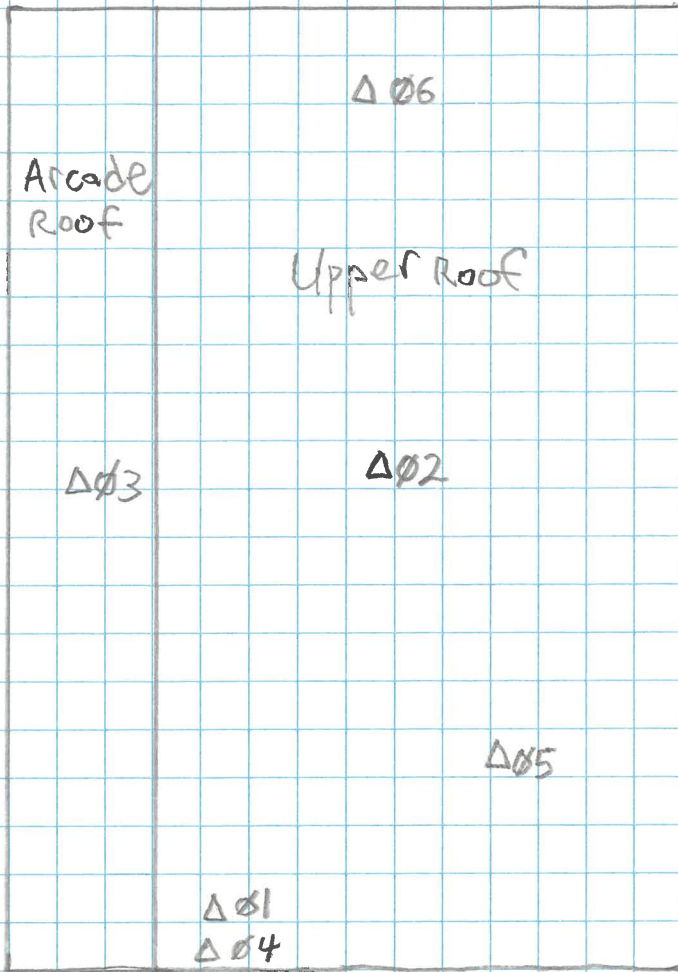

Bldg M1/M2

Δ = Roof Bulk
Sample Location

San Bernardino HS

18-16-106-04
06/18/21

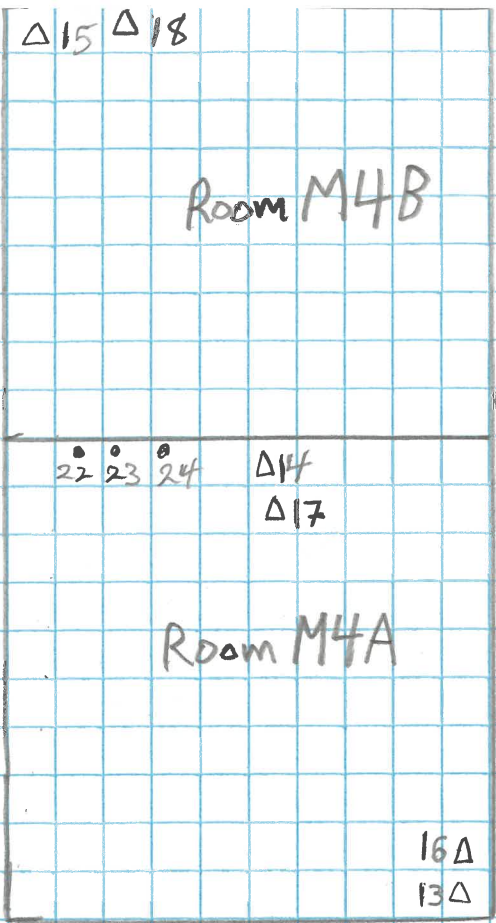

↑
 N
 (NOT TO Scale)

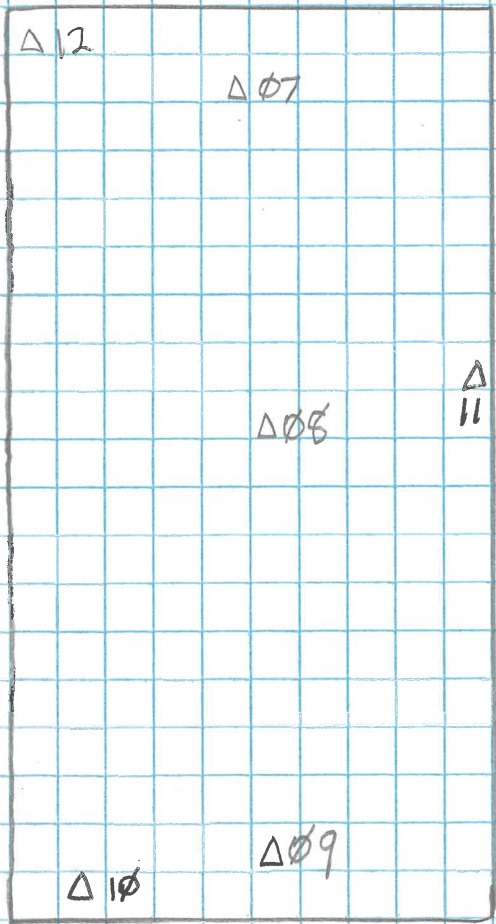

Bldg M4

Bldg M3

\bullet = Bulk samp
 Location
 Δ = Roof Bulk
 Sample Loca

San Bernardino
 18-16-106-04
 06/18/21

Application for Authorization to Use





Converse Consultants

Geotechnical Engineering, Environmental & Groundwater Science, Inspection & Testing Services

Application for Authorization to Use

TO: Converse Consultants
717 South Myrtle Avenue
Monrovia, California 91016

Project Title & Date: _____

Project Address: _____

FROM: (Please identify name & address of person/entity applying for permission to use the referenced report.)

Applicant _____ hereby applies for permission to use the referenced report in order to:

Applicant wishes or needs to use the referenced report because:

Applicant also understands and agrees that the referenced document is a copyrighted document and shall remain the sole property of Converse Consultants. Unauthorized use or copying of the report is strictly prohibited without the express written permission of Converse Consultants. *Applicant* understands and agrees that Converse Consultants may withhold such permission at its sole discretion, or grant such permission upon agreement to Terms and Conditions, such as the payment of a re-use fee, amongst others.

Applicant Signature: _____

Applicant Name (print): _____

Title: _____

Date: _____





Converse Consultants

Geotechnical Engineering, Environmental & Groundwater Science, Inspection & Testing Services

July 12, 2021

Ms. Nellie J. Karbum
Facilities Planning & Development Department
San Bernardino City Unified School District
956 West 9th Street
San Bernardino, California 92411

Subject: **SUMMARY OF CERAMIC TILE GROUT SAMPLING**
San Bernardino High School
Classroom Building M1/M2
1850 North E Street
San Bernardino, California
Converse Project No. 18-16-106-04

Ms. Karbum:

Attached is a summary of the bulk asbestos sampling of the suspect ceramic tile grout in the restroom in Building M1/M2. The additional sampling was completed on July 8, 2021. The sampling was completed by Rodney Stansfield, a Certified Asbestos Consultant.

On Thursday, July 8th, bulk samples were collected of the grout to the ceramic wall and floor tiles. Both materials were found to be negative for asbestos. A copy of the analytical report is attached to this letter.

We appreciate the opportunity to be of service to you. If you should have any questions or comments regarding these results, please contact either Laura Tanaka at 626-930-1261 or Norman Eke at (626) 930-1260.

Sincerely,

CONVERSE CONSULTANTS

Laura Tanaka, CAC
Principal Environmental Scientist
Atch.



LA Testing

520 Mission Street South Pasadena, CA 91030

Tel/Fax: (323) 254-9960 / (323) 254-9982

<http://www.LATesting.com> / pasadenalab@lateesting.com

LA Testing Order: 322112399

Customer ID: 32CONV56

Customer PO: 18-16-106-04

Project ID:

Attention: Laura Tanaka
Converse Consultants
717 S Myrtle Avenue
Monrovia, CA 91016

Phone: (626) 930-1260

Fax: (626) 930-1212

Received Date: 07/08/2021 12:30 PM

Analysis Date: 07/08/2021 - 07/09/2021

Collected Date: 07/08/2021

Project: 18-16-106-04

Test Report: Asbestos Analysis of Bulk Materials via EPA 600/R-93/116 Method using Polarized Light Microscopy

Sample	Description	Appearance	Non-Asbestos		Asbestos
			% Fibrous	% Non-Fibrous	% Type
0708-01-Grout <small>322112399-0001</small>	M1/M2 Restroom	Gray Non-Fibrous Homogeneous		100% Non-fibrous (Other)	None Detected
0708-01-Mastic Like <small>322112399-0001A</small>	M1/M2 Restroom	Beige Non-Fibrous Homogeneous		100% Non-fibrous (Other)	None Detected
0708-01-Plaster <small>322112399-0001B</small>	M1/M2 Restroom	White Non-Fibrous Homogeneous		100% Non-fibrous (Other)	None Detected
0708-02-Grout 1 <small>322112399-0002</small>	M1/M2 Restroom	Gray Non-Fibrous Homogeneous		100% Non-fibrous (Other)	None Detected
0708-02-Mastic Like <small>322112399-0002A</small>	M1/M2 Restroom	Beige Non-Fibrous Homogeneous		100% Non-fibrous (Other)	None Detected
0708-02-Plaster <small>322112399-0002B</small>	M1/M2 Restroom	White Non-Fibrous Homogeneous		100% Non-fibrous (Other)	None Detected
0708-02-Grout 2 <small>322112399-0002C</small>	M1/M2 Restroom	White Non-Fibrous Homogeneous		100% Non-fibrous (Other)	None Detected
0708-03-Grout 1 <small>322112399-0003</small>	M1/M2 Restroom	White Non-Fibrous Homogeneous		100% Non-fibrous (Other)	None Detected
0708-03-Grout 2 <small>322112399-0003A</small>	M1/M2 Restroom	Tan Non-Fibrous Homogeneous		100% Non-fibrous (Other)	None Detected
0708-03-Mastic Like <small>322112399-0003B</small>	M1/M2 Restroom	White Non-Fibrous Homogeneous		100% Non-fibrous (Other)	None Detected
0708-04-Ceramic Tile <small>322112399-0004</small>	M1/M2 Restroom	White Non-Fibrous Homogeneous		100% Non-fibrous (Other)	None Detected
0708-04-Grout <small>322112399-0004A</small>	M1/M2 Restroom	Gray Non-Fibrous Homogeneous		100% Non-fibrous (Other)	None Detected
0708-04-Mortar <small>322112399-0004B</small>	M1/M2 Restroom	Gray/Beige Non-Fibrous Homogeneous		100% Non-fibrous (Other)	None Detected
0708-05-Ceramic Tile <small>322112399-0005</small>	M1/M2 Restroom	White Non-Fibrous Homogeneous		100% Non-fibrous (Other)	None Detected
0708-05-Grout 1 <small>322112399-0005A</small>	M1/M2 Restroom	Gray Non-Fibrous Homogeneous		100% Non-fibrous (Other)	None Detected
0708-05-Grout 2 <small>322112399-0005B</small>	M1/M2 Restroom	Red Non-Fibrous Homogeneous		100% Non-fibrous (Other)	None Detected

Initial report from: 07/09/2021 10:23:00



LA Testing

520 Mission Street South Pasadena, CA 91030

Tel/Fax: (323) 254-9960 / (323) 254-9982

<http://www.LATesting.com> / pasadenalab@lateesting.com

LA Testing Order: 322112399

Customer ID: 32CONV56

Customer PO: 18-16-106-04

Project ID:

Test Report: Asbestos Analysis of Bulk Materials via EPA 600/R-93/116 Method using Polarized Light Microscopy

Sample	Description	Appearance	Non-Asbestos		Asbestos
			% Fibrous	% Non-Fibrous	% Type
0708-05-Mortar 322112399-0005C	M1/M2 Restroom	Gray/Beige Non-Fibrous Homogeneous		100% Non-fibrous (Other)	None Detected
0708-06-Grout 1 322112399-0006	M1/M2 Restroom	White Non-Fibrous Homogeneous		100% Non-fibrous (Other)	None Detected
0708-06-Grout 2 322112399-0006A	M1/M2 Restroom	Gray/Tan Non-Fibrous Homogeneous		100% Non-fibrous (Other)	None Detected

Analyst(s)

Humberto Espinoza Bajo (14)

Rosa Mendoza (5)

Jerry Drapala Ph.D, Laboratory Manager
or Other Approved Signatory

LA Testing maintains liability limited to cost of analysis. Interpretation and use of test results are the responsibility of the client. This report relates only to the samples reported above, and may not be reproduced, except in full, without written approval by LA Testing. LA Testing bears no responsibility for sample collection activities or analytical method limitations. The report reflects the samples as received. Results are generated from the field sampling data (sampling volumes and areas, locations, etc.) provided by the client on the Chain of Custody. Samples are within quality control criteria and met method specifications unless otherwise noted. The above analyses were performed in general compliance with Appendix E to Subpart E of 40 CFR (previously EPA 600/M4-82-020 "Interim Method") but augmented with procedures outlined in the 1993 ("final") version of the method. This report must not be used by the client to claim product certification, approval, or endorsement by NVLAP, NIST or any agency of the federal government. Non-friable organically bound materials present a problem matrix and therefore LA Testing recommends gravimetric reduction prior to analysis. Unless requested by the client, building materials manufactured with multiple layers (i.e. linoleum, wallboard, etc.) are reported as a single sample. Estimation of uncertainty is available on request.

Samples analyzed by LA Testing South Pasadena, CA NVLAP Lab Code 200232-0, CA ELAP 2283

Initial report from: 07/09/2021 10:23:00



Asbestos Chain of Custody

LA Testing Order Number (Lab Use Only):
#322112399

LA TESTING
520 MISSION STREET
S. PASADENA, CA 91030
PHONE: (323) 254-9960
FAX: (323) 254-9982

Company : Converse Consultants		LA Testing-Bill to: <input checked="" type="checkbox"/> Same <input type="checkbox"/> Different <small>If Bill to is Different note instructions in Comments**</small>	
Street: 717 S. Myrtle Avenue		<i>Third Party Billing requires written authorization from third party</i>	
City: Monrovia	State/Province: CA	Zip/Postal Code: 91016	Country: USA
Report To (Name): Laura Tanaka		Fax #:	
Telephone #: (626) 930-1261		Email Address: Itanaka@converseconsultants.com	
Project Name/Number: 18-16-106-04			
Please Provide Results: <input type="checkbox"/> Fax <input checked="" type="checkbox"/> Email		Purchase Order: 181610604	U.S. State Samples Taken: CA

Turnaround Time (TAT) Options* - Please Check

3 Hour
 6 Hour
 24 Hour
 48 Hour
 72 Hour
 96 Hour
 1 Week
 2 Week

*For TEM Air 3 hours through 6 hours, please call ahead to schedule. *There is a premium charge for 3 Hour TEM AHERA or EPA Level II TAT. You will be asked to sign an authorization form for this service. Analysis completed in accordance with LA Testing's Terms and Conditions located in the Analytical Price Guide.

PCM - Air <input type="checkbox"/> NIOSH 7400 <input type="checkbox"/> w/ OSHA 8hr. TWA PLM - Bulk (reporting limit) <input checked="" type="checkbox"/> PLM EPA 600/R-93/116 (<1%) <input type="checkbox"/> PLM EPA NOB (<1%) Point Count <input type="checkbox"/> 400 (<0.25%) <input type="checkbox"/> 1000 (<0.1%) Point Count w/Gravimetric <input type="checkbox"/> 400 (<0.25%) <input type="checkbox"/> 1000 (<0.1%) <input type="checkbox"/> NYS 198.1 (friable in NY) <input type="checkbox"/> NYS 198.6 NOB (non-friable-NY) <input type="checkbox"/> NIOSH 9002 (<1%)	TEM - Air <input type="checkbox"/> 4-4.5hr TAT (AHERA only) <input type="checkbox"/> AHERA 40 CFR, Part 763 <input type="checkbox"/> NIOSH 7402 <input type="checkbox"/> EPA Level II <input type="checkbox"/> ISO 10312 TEM - Bulk <input type="checkbox"/> TEM EPA NOB <input type="checkbox"/> NYS NOB 198.4 (non-friable-NY) <input type="checkbox"/> Chatfield SOP <input type="checkbox"/> TEM Mass Analysis-EPA 600 sec. 2.5 TEM - Water: EPA 100.2 Fibers >10µm <input type="checkbox"/> Waste <input type="checkbox"/> Drinking All Fiber Sizes <input type="checkbox"/> Waste <input type="checkbox"/> Drinking	TEM- Dust <input type="checkbox"/> Microvac - ASTM D 5755 <input type="checkbox"/> Wipe - ASTM D6480 <input type="checkbox"/> Carpet Sonication (EPA 600/J-93/167) Soil/Rock/Vermiculite <input type="checkbox"/> PLM CARB 435 - A (0.25% sensitivity) <input type="checkbox"/> PLM CARB 435 - B (0.1% sensitivity) <input type="checkbox"/> TEM CARB 435 - B (0.1% sensitivity) <input type="checkbox"/> TEM CARB 435 - C (0.01% sensitivity) <input type="checkbox"/> EPA Protocol (Semi-Quantitative) <input type="checkbox"/> EPA Protocol (Quantitative) Other: <input type="checkbox"/>
---	--	--

Check For Positive Stop - Clearly Identify Homogenous Group

Samplers Name: <i>Rodney Stansfield</i>	Samplers Signature: <i>Rodney Stansfield</i>
--	---

Sample #	Sample Description	Volume/Area (Air) HA # (Bulk)	Date/Time Sampled
	See Attached	See Attached	07/08/21

Client Sample # (s):	Total # of Samples:
Relinquished (Client): <i>Rodney Stansfield</i> Date: <i>07/08/21</i> Time: <i>12:15</i>	
Received (Lab): <i>Edwin Trojillo (PB)</i> Date: <i>7/8/21</i> Time: <i>12:30pm</i>	
Comments/Special Instructions:	

#322112399



Converse Consultants

Monrovia Office
717 S. Myrtle Avenue
Monrovia, CA 91016
(626) 930-1200

Costa Mesa Office
3176 Pullman St., Suite 108
Costa Mesa, CA 92626
(714) 444-9660

Rancho Office
8333 Foothill Blvd. Suite 104
Rancho Cucam, CA 91730
(909) 796-0544

BULK SAMPLE LOG

Project Name: San Bernardino High School Collected By: RDS

Project No.: 18-16-106-04 Date: 07/08/21

HOMOGENEOUS MATERIAL: Wall Tile Grout

Sample Number	Location/Description	Approx. Area/Sq. Ft.	Condition/Comments
0708-01	M1/M2 Restroom	240	Good
0708-02	↓	↓	↓
0708-03	↓	↓	↓

Additional Comments: Ceramic wall tiles



Converse Consultants

Monrovia Office
717 S. Myrtle Avenue
Monrovia, CA 91016
(626) 930-1200

Costa Mesa Office
3176 Pullman St., Suite 108
Costa Mesa, CA 92626
(714) 444-9660

Rancho Office
8333 Foothill Blvd. Suite 104
Rancho Cucam, CA 91730
(909) 796-0544

BULK SAMPLE LOG

Project Name: San Bernardino High School Collected By: RDS

Project No.: 18-16-106-04 Date: 07/08/21

HOMOGENEOUS MATERIAL: Floor Tile Grout

Sample Number	Location/Description	Approx. Area/Sq. Ft.	Condition/Comments
0708-04	M1/M2 Restroom	100	Good
0708-05	↓	↓	↓
0708-06	↓	↓	↓

Additional Comments: Ceramic Floor Tiles

Paul Stansfield 07/08/21

↑
N

07/08/21
18-16-106-04
★ = Bulk Sample
Location

Building M2

M1/M2 Restroom

★01
★02
★04

03
★

05★
06★

M1 Lower Arcade

Building M1

Abatement Specifications – PCBs, Fluorescent Light Tubes, Smoke Detectors & Aerosols

**San Bernardino High School
Classroom Buildings M1/M2, M3, and M4
1850 North E Street
San Bernardino, California**

Prepared For:

**San Bernardino City Unified School District
956 West 9th Street
San Bernardino, California 92411**

Prepared By:

**Converse Consultants
717 South Myrtle Avenue
Monrovia, California 91016
Converse Project No. 18-16-106-04**

July 14 , 2021

SECTION 02 84 16

**HANDLING OF LIGHTING BALLASTS CONTAINING PCBS,
FLUORESCENT LIGHT TUBES CONTAINING MERCURY, SMOKE DETECTORS AND AEROSOLS**
Revision 00

PART 1 – GENERAL

- .01 Summary and Scope
- .02 References
- .03 Qualifications
- .04 Definitions
- .05 Submittals and Notices
- .06 Site Security
- .07 Emergency Planning
- .08 Meetings
- .09 Delivery, Storage and Handling
- .10 Insurance
- .11 Bonding
- .12 Project Schedule

PART 2- PRODUCTS

- .01 Materials
- .02 Equipment

PART 3 - EXECUTION

- .01 Work Procedure
- .02 PCB Spill Cleanup Requirements
- .03 Removal
- .04 Storage
- .05 Disposal
- .06 Recycling of Mercury in Lamps
- .07 Smoke Detectors and Aerosols
- .08 Alternative Procedures

END OF CONTENTS

PART 1 - GENERAL

1.01 SUMMARY AND SCOPE

- A. Applicable provisions of Division 01 – General Requirements shall govern work under this section.
- B. Perform all operations in connection with handling of light ballasts containing PCBs, light tubes, smoke detectors and aerosols. Work as shown on drawings, specific scopes of work, and/or as specified herein.
- C. Description of Work – This specification is for the handling, removal, containment, and disposal/recycling of the following items:
- 98 fluorescent light fixtures. Converse assumes one ballast per fixture. All ballasts which are not clearly marked “No PCBs” or “PCB Free” shall be assumed to contain PCBs, and shall be removed intact, packaged, and disposed of appropriately. All other ballasts may be incinerated or recycled at an appropriate disposal site.
 - A total of 25 smoke detectors were observed in the subject buildings. Smoke detectors that are to be demolished need to be disassembled and categorized as either ionization detector (radioactive) or photoelectric detectors, which can be completed by checking for the required radioactive sticker on the baseplate. Photoelectric detectors may be discarded as construction debris. Ionization detectors will require appropriate off-site disposal per appropriate regulations.
 - Eight (8) aerosol cans of paint were observed in Room M3. These should be disposed of properly if no longer in use.
- D. Special Precautions: Coordinate with the Owner Representative for the shutdown and isolation of all electrical circuits and air movement systems within the regulated area. Refer to Part 3, Execution, relative to shutdown of mechanical and electrical systems. The provision of temporary facilities and/or utilities must be arranged prior to each project as necessary and will be the responsibility of the Contractor.
- A. Special Circumstances: Emergency response may be necessary during non-working hours requiring Contractor personnel to be on-site within 3 hours of notification (e.g., due to weather, vandalism, burglary, etc.).
- B. Restoration: Not Applicable.
- C. Related work specified elsewhere (enclosed):

<u>Section Title</u>	<u>Section Number</u>
Removal and Disposal of Asbestos Materials	02 82 13
Removal and Disposal of Materials Containing Lead	02 83 33

1.02 REFERENCES

- A. General Reference:

All work under this contract shall be done in strict accordance with all applicable Federal, State, and local regulations, standards and codes governing handling, storage, and disposal of PCBs,

mercury, and radioactive materials. The most recent edition of any relevant regulation in force at the time of bid opening shall be in effect. Where conflict among the laws, rules, regulations, or with these specifications exists, the most stringent requirements shall be utilized.

B. Specific References:

Occupational Safety and Health Administration (OSHA) Title 29 Code of Federal Regulations (CFR):

29 CFR 1910.1000 - Air Contaminants

Environmental Protection Agency (EPA) Title 40 Code of Federal Regulations (CFR):

40 CFR 82 - Protection of Stratospheric Ozone

40 CFR 260 - Hazardous Waste Management System: General

40 CFR 261 - Identification and Listing of Hazardous Waste

40 CFR 262 - Standards Applicable to Generators of Hazardous Waste

40 CFR 263 - Standards Applicable to Transporters of Hazardous Waste

40 CFR 264 - Standards for Owners and Operators of Hazardous Waste Treatment, Storage, and Disposal Facilities

40 CFR 265 - Interim Status Standards for Owners and Operators of Hazardous Waste Treatment, Storage, and Disposal Facilities

40 CFR 268 - Land Disposal Restrictions

40 CFR 270 - EPA Administered Permit Programs: The Hazardous Waste Permit Program

40 CFR 273 - Standards for Universal Waste Management

40 CFR 761 - Polychlorinated Biphenyls (PCBs) Manufacturing, Processing, Distribution in Commerce, and Use Prohibitions

Department of Transportation (DOT) Title 49 Code of Federal Regulations:

49 CFR 178 - Specifications for Packagings

California Department of Toxic Substances Control (DTSC)

22 CCR Division 4.5, Chapters:

10 Hazardous Waste Management System: General

13 Standards Applicable to Transporters of hazardous Waste

16 Recyclable Materials

18 Land Disposal Restrictions

23 Standards for Universal Waste Management

42 Requirements for Management of Fluorescent Light Ballasts Which Contain Polychlorinated Biphenyls (PCBs)

1.03 QUALIFICATIONS

A. Worker Training

A qualified instructor shall instruct and certify the training of all persons involved. The instruction shall include: the dangers of PCBs, mercury, hazardous materials and decontamination, safe work practices, and applicable OSHA, Cal/OSHA and EPA regulations.

1.04 DEFINITIONS

ACGIH:

American Conference of Governmental Industrial Hygienists

AIHA: American Industrial Hygiene Association

ANSI: American National Standards Institute

ASTM:
American Society for Testing and Materials (now ASTM International)

Authorized Visitor:
The Building Owner (and designated representatives) and any representative of a regulatory agency having jurisdiction over the project.

California Division of Occupational Safety and Health (Cal/DOSH):
The Occupational Safety and Health Enforcement Section aka Cal DOSH or Cal/OSHA which is a part of the California Division of Industrial Relations.

Certified Industrial Hygienist (CIH):
An industrial hygienist certified in Comprehensive Practice by the American Board of Industrial Hygiene.

Chlorofluorocarbons (CFCs):
Refrigerants used in air conditioners and other cooling devices. They have been regulated by the EPA due to their ozone depletion potential.

Competent Person:
Means one who is capable of identifying existing asbestos hazards in the workplace and who has the authority to take prompt corrective measures to eliminate them.

Consultant:
Means the person, persons, and/or company contracted by the Owner to provide third party oversight of the project described in these specifications. The Consultant shall have no business relationship with the Contractor.

Contractor:
Means the person, persons, and/or company contracted by the Owner to provide the services specified herein.

Decontamination Enclosure:
A decontamination system consisting of a clean room, a shower room, and an equipment room separated from each other and from the regulated area by airlocks. This system is used for all workers to enter and exit the regulated area and may also serve as equipment and waste pass out on small jobs.

EPA: U. S. Environmental Protection Agency

Lamp:
Lamp, also referred to as "universal waste lamp", or fluorescent light tube, is defined as the bulb or tube portion of an electric lighting device. A lamp is specifically designed to produce radiant energy, most often in the ultraviolet, visible, and infra-red regions of the electromagnetic spectrum. Examples of common universal waste electric lamps include, but are not limited to, fluorescent, high intensity discharge, neon, mercury vapor, high pressure sodium, and metal halide lamps.

Leak:

Leak or leaking means any instance in which a PCB article, PCB container, or PCB equipment has any PCBs on any portion of its external surface.

OSHA:

The Occupational Safety and Health Administration; may also be referenced instead of Cal/DOSH or Cal/OSHA equivalent regulations.

Owner:

Means the owner of the properties in which the activities described in these specifications are to be performed. The Owner will also be the employer of the personnel working in the affected building.

(designated) Owner's Representative:

Means the person, persons, or company who monitors the work specified in this document with the Owner's interests as a priority. Compliance with these specifications will be monitored by the Owner's Representative. The Consultant and the Owner's Representative will be the same unless otherwise specified.

Polychlorinated Biphenyls (PCBs):

PCBs as used in this specification shall mean the same as PCBs, PCB containing lighting ballast, and PCB container, as defined in 40 CFR 761. They are commonly found in capacitors and transformers manufactured before 1979 as a part of their dielectric fluids and coolants.

Spill:

Spill means both intentional and unintentional spills, leaks, and other uncontrolled discharges when the release results in any quantity of PCBs running off or about to run off the external surface of the equipment or other PCB source, as well as the Contamination resulting from those releases.

Universal Waste:

Universal Waste means any of the following hazardous wastes that are managed under the universal waste requirements 40 CFR 273 and 22 CCR Division 4.5:
Lamps as described in Sec. 273.5 and Division 4.5, Chapter 23.

1.05 SUBMITTALS AND NOTICES

A. Qualified Instructor

Submit the qualifications, experience, name, address, and telephone number of the qualified instructor selected to perform the duties in paragraph 1.03 A.

B. Removal Work Plan

Submit a written job-specific Work Plan at least 14 working days before commencing work of the work procedures to be used in the removal, packaging, and storage. Include in the plan: requirements for Personal Protective Equipment (PPE), spill cleanup procedures and equipment, and eating, smoking and restroom procedures. Obtain approval of the plan by the Owner's Representative prior to the start of removal work.

C. Recycling Plan

Submit a written Plan at least ten (10) working days before commencing work. The Plan shall comply with applicable requirements of Federal, State, and local regulations and address:

1. Estimated quantities of wastes to be generated, disposed of, and recycled.
2. Names and qualifications of each Contractor that will be transporting, storing, treating, and disposing of the wastes, including the facility location.
3. Names and qualifications (experience and training) of personnel who will be working on-site.
4. Spill prevention, containment, and cleanup contingency measures to be implemented.
5. Procedures and schedule for waste removal, containment, storage, transportation, disposal and/or recycling. Wastes shall be cleaned up and containerized daily.

D. Transporter EPA Notification - Certificate of Disposal and/or Recycling

Submit to Owner Representative before application for payment and within 30 days of the date that the disposal of waste identified on the manifest was completed. The hazardous materials may be stored on site at a location designated by the Owner before transportation and disposal at an EPA-approved disposal site. Contractor shall submit documentation of proper disposal or recycling of the hazardous materials to the Owner. The documentation shall be included as part of the Contractor's post abatement submittal which is a project requirement that must be submitted before the project is considered complete.

E. Regulation Documents

Maintain at all times one copy each at the office and one copy each in view at the job site of 29 CFR 1910.1000, 40 CFR 260, 40 CFR 261, 40 CFR 262, 40 CFR 263, 40 CFR 265, 40 CFR 268, 40 CFR 270, 40 CFR 273 and of the Contractor removal work plan and disposal plan for PCB and for associated mercury-containing lamps.

1.06 SITE SECURITY

- A. Contractor shall be responsible for the security of the regulated area(s) during abatement operations in order to protect work efforts and Owner equipment. Contractor will also be responsible for the security of all their equipment and materials on the job site.
- B. The regulated area shall be restricted to only authorized, trained, and protected personnel. These may include the Contractor's employees, employees of subcontractors, State representatives, and any other designated individuals. A list of authorized personnel shall be established prior to job start and posted in the clean room of the decontamination facility. A log book shall be maintained in the clean room area of the decontamination system. Anyone who enters the regulated area must record name, affiliation, time in, and time out for each entry.
- C. Contractor shall assure any unauthorized individual entering the regulated area is decontaminated (if required), evict them, and notify the Owner Representative of the actions taken and the identity of the unauthorized individual.
- D. Access to the regulated area shall be through a single decontamination system. All other means of access (doors, windows, hallways, etc.) shall be blocked or locked so as to prevent entry to or exit from the regulated area. The only exceptions to this rule are the waste pass-out air lock

which shall be sealed except during the removal of containerized asbestos waste from the regulated area, and emergency exits in case of fire or accident. Emergency exits shall not be locked from the inside. However, they shall be sealed with polyethylene sheeting and tape until needed.

1.07 EMERGENCY PLANNING

- A. Emergency procedures shall be in written form and prominently posted in the clean change area and equipment room of the worker decontamination area. Everyone prior to entering the regulated area must read and sign these procedures to acknowledge receipt and understanding of work site layout, location of emergency exits and emergency procedures.
- B. Contractor employees shall be trained in evacuation procedures in the event of workplace emergencies under the following conditions:
 - 1. For non-life-threatening situations, employees injured or otherwise incapacitated shall decontaminate following normal procedures with assistance from fellow workers, if necessary, before exiting the workplace to obtain proper medical treatment.
 - 2. For life-threatening injury or illness, worker decontamination shall take least priority; after measures to stabilize the injured worker, remove the worker from the workplace and secure proper medical treatment.
- C. Telephone numbers of all emergency response personnel shall be prominently posted in the clean change area and equipment room along with the location of the nearest telephone.
- D. Exit routes should be clearly identified in the containment.
- E. Procedures to prevent and treat heat stress must be posted in the clean room area. Workers shall be provided easy access to drinking water outside of the regulated area(s) and encouraged to drink frequently.

1.08 MEETINGS

- A. Refer to Division 1.

1.09 DELIVERY, STORAGE, AND HANDLING

- A. Refer to Division 1.

1.10 INSURANCE REQUIREMENTS

- A. Refer to Division 1 and Owner and General Contractor insurance requirements.

1.11 BONDING REQUIREMENTS

- A. Refer to Division 1 and Owner and General Contractor Subcontractor Agreements.

1.12 PROJECT SCHEDULE

- A. Project Start Date: Refer to Owner or General Contractor's Instructions to Bidders and Published Project Schedule. Multiple notices to regulatory agencies and mobilizations will be required, as the project is phased.

PART 2 - PRODUCTS

2.01 MATERIALS

- A. Intact 55-gallon DOT-approved metal drums with securable lids, or similarly protective containers, shall be used for the storage of the PCB light ballasts until disposal. The drums shall be able to contain any fluid leakage from the ballasts placed in them.
- A. Rigid tubes, long boxes, or other similarly protective containers should be used for the storage of the fluorescent light bulbs to prevent breakage until they are disposed or recycled.
- B. At least one small commercially available PCB spill kit with a test kit in it (e.g., CLOR-N-Oil™) and one mercury spill kit with a test kit in it to determine cleanup effectiveness.

2.02 EQUIPMENT

- A. If there is any evidence of leakage from the light ballasts, then special gloves shall be used when handling the ballasts. The gloves must be shown to resist PCB permeation for an entire shift. Examples include Viton® and Silver Shield® type gloves.
- B. Impact resistant safety glasses (ANSI approved) and/or face shields shall be used when handling fluorescent light tubes.
- C. Any other PPE recommended for use by the Consultant when handling the light ballasts, light tubes, thermostat, and radioactive sources in the smoke detectors or exit signs.

PART 3 - EXECUTION

3.01 WORK PROCEDURE

Furnish labor, materials, services, and equipment necessary for the removal of PCB containing lighting ballasts, associated mercury-containing fluorescent lamps, smoke detectors and aerosols in accordance with local, State, or Federal regulations. Do not expose PCBs to open flames or other high temperature sources since toxic decomposition by-products may be produced. Do not break mercury containing fluorescent lamps. Ensure that work operations or processes involving PCB or PCB-contaminated materials are conducted in accordance with 40 CFR 761, 40 CFR 262 40 CFR 263, and the applicable requirements of this section, including but not limited to:

- A. Obtaining suitable PCB and mercury-containing lamp storage sites.
- B. Notifying the Owner prior to commencing the operation.
- C. Reporting leaks and spills to the Owner.

- D. Cleaning up spills.
- E. Inspecting PCB and PCB-contaminated items and waste containers for leaks and forwarding copies of inspection reports to the Owner.
- F. Maintaining inspection, inventory and spill records.

3.02 PCB SPILL CLEANUP REQUIREMENTS

A. PCB Spills Reporting

Immediately report to the Owner any PCB spills.

B. PCB Spill Control Area

Rope off an area around the edges of a PCB leak or spill and post a "PCB Spill Authorized Personnel Only" caution sign. Immediately transfer leaking items to a drip pan or other container.

C. PCB Spill Cleanup

40 CFR 761, Subpart G requires cleanup of spills as soon as possible, but no later than 24 hours of its discovery. Mop up the liquid with rags or other conventional absorbent. The spent absorbent shall be properly contained and disposed of as solid PCB waste. Use the PCB spill and test kit to properly clean up the spill and test afterwards for cleaning effectiveness.

D. Records and Certification

Document the cleanup with records of decontamination in accordance with 40 CFR 761, Section 125 by providing test results of cleanup and certification of decontamination.

3.03 REMOVAL

A. Ballasts

As ballasts are removed from the lighting fixture, inspect label on ballast. Ballasts without a "No PCB" label shall be assumed to contain PCBs and containerized and disposed of as required under paragraphs STORAGE FOR DISPOSAL and DISPOSAL.

B. Fluorescent Lamps

Remove fluorescent lighting tubes/lamps from the lighting fixture and carefully place (unbroken) into appropriate containers (original transport boxes or equivalent). In the event of a lighting tube/lamp breaking, sweep and place waste in double plastic taped bags and dispose of as universal waste as specified herein. If the bulb is broken, then the debris shall be thoroughly cleaned up using the mercury spill and test kit. Test the area to assure adequate cleaning has occurred.

C. Smoke Detectors

A total of 25 smoke detectors were observed in the subject buildings. Smoke detectors that are to be demolished need to be disassembled and categorized as either ionization detector (radioactive) or photoelectric detectors, which can be completed by checking for the required

radioactive sticker on the baseplate. Photoelectric detectors may be discarded as construction debris. Ionization detectors will require appropriate off-site disposal per appropriate regulations.

D. Aerosols

Eight (8) aerosol cans of paint were observed in Room M3. These should be disposed of properly if no longer in use per appropriate regulation.

3.04 STORAGE

A. Storage Containers for PCBs

49 CFR 178 requires PCBs be stored in containers approved by DOT for PCB.

B. Storage Containers for Lamps, Smoke Detectors and Aerosols

Store in appropriate DOT containers; stored and labeled for transport in accordance with applicable regulations.

C. Labeling of Waste Containers

Label with the following:

1. Date the item was placed in storage and the name of the Owner.
2. "Caution Contains PCB," conforming to 40 CFR 761, CFR Subpart C. Affix labels to PCB waste containers.
3. Label mercury-containing lamp waste in accordance with 40 CFR 273. Affix labels to all lighting waste containers.
4. Label all waste in accordance with applicable regulation.

3.05 DISPOSAL

Dispose of in accordance with EPA, DOT, DTSC and local regulations at a permitted site under appropriate manifest.

A. EPA Identification Number

1. Federal regulations 40 CFR 761, 40 CFR 263, and 22 CCR Division 4.5 require that generators, transporters, commercial storers, and disposers of PCB waste possess U.S. EPA identification numbers. The contractor shall verify that the activity has a U.S. EPA generator identification number for use on the Uniform Hazardous Waste manifest. If not, the contractor shall advise the Owner that it must file and obtain an I.D. number with EPA prior to commencement of removal work.
2. For mercury containing lamp removal, Federal regulations 40 CFR 273 require that large quantity handlers of Universal waste (LQHUW) must provide notification of universal waste management to the appropriate EPA Region (or state director in authorized states), obtain an EPA identification number, and retain for three years records of off-site shipments of universal waste. The contractor shall verify that the Owner has a U.S. EPA

generator identification number for use on the Universal Waste manifest. If not, the contractor shall advise of the activity that it must file and obtain an I.D. number with EPA prior to commencement of removal work.

3. A total of 25 smoke detectors were observed in the subject buildings. Smoke detectors that are to be demolished need to be disassembled and categorized as either ionization detector (radioactive) or photoelectric detectors, which can be completed by checking for the required radioactive sticker on the baseplate. Photoelectric detectors may be discarded as construction debris. Ionization detectors will require appropriate off-site disposal per appropriate regulations.
4. Eight (8) aerosol cans of paint were observed in Room M3. These should be disposed of properly if no longer in use per appropriate regulation.

B. Transporter Certification

Comply with disposal and transportation requirements outlined in 40 CFR 761 and 40 CFR 263. Before transporting the PCB waste, sign and date the manifest acknowledging acceptance of the PCB waste from the Owner. Return a signed copy to the Owner (Owner's Representative) before leaving the job site. Ensure that the manifest accompanies the PCB waste at all times. Submit transporter certification of notification to EPA of their PCB waste activities (EPA Form 7710-53).

C. Certificate of Disposal and/or Recycling

Certificate for the PCBs and PCB items disposed shall include:

1. The identity of the disposal and or recycling facility, by name, address, and EPA identification number.
2. The identity of the PCB waste affected by the Certificate of Disposal including reference to the manifest number for the shipment.
3. A statement certifying the fact of disposal and or recycling of the identified PCB waste, including the date(s) of disposal, and identifying the disposal process used.
4. A certification as defined in 40 CFR 761.

3.06 RECYCLING OF MERCURY IN LAMPS

Handle lamps as a Universal Waste (40 CFR 273, 22 CCR Division 4.5 Chapter 23) and recycle at an approved recycling facility.

3.07 SMOKE DETECTORS AND AEROSOLS

Documentation for ultimate disposition to be provided to Owner and Project Environmental Consultant for recordkeeping and close-out report.

3.08 ALTERNATIVE PROCEDURES

- A. If specified procedures cannot be utilized, a request shall be made in writing to the Owner Representative and Consultant providing details of the problem encountered and recommended alternatives.

- B. Alternative procedures shall provide equivalent or greater protection than procedures that are replaced.
- C. Any alternative procedure must be approved in writing by the Environmental Consultant and the Owner Representative prior to the implementation of the procedure.

END OF SECTION

Abatement Specifications - Asbestos

**San Bernardino High School
Classroom Buildings M1/M2, M3, and M4
1850 North E Street
San Bernardino, California**

Prepared For:

**San Bernardino City Unified School District
956 West 9th Street
San Bernardino, California 92411**

Prepared By:

**Converse Consultants
717 South Myrtle Avenue
Monrovia, California 91016
Converse Project No. 18-16-106-04**

July 14 , 2021

SECTION 02 82 13

ASBESTOS ABATEMENT

Revision 00

CONTENTS

SUMMARY (previous)

PART 1 – GENERAL

- .01 Summary and Scope
- .02 References
- .03 Qualifications
- .04 Definitions
- .05 Submittals and Notices
- .06 Site Security
- .07 Emergency Planning
- .08 Meetings
- .09 Delivery, Storage and Handling
- .10 Insurance Requirements
- .11 Bonding Requirements
- .12 Project Schedule

PART 2- PRODUCTS

- .01 Materials
- .02 Equipment

PART 3 - EXECUTION

- .01 General Compliance Measures
- .02 Class II Asbestos Removal Work (Exterior)
- .03 Decontamination Enclosure System
- .04 Workplace Entry and Exit Procedures
- .05 Waste Container Pass-Out Procedure
- .06 Water Collection and Disposal
- .07 Wet Removal Procedure
- .08 Air Monitoring
- .09 Work Stoppage
- .10 Cleanup Procedure
- .11 Clearance Testing
- .12 Reestablishment of Work Areas
- .13 Disposal Procedures
- .14 OSHA Personal Air Monitoring
- .15 Alternative Procedures

END OF CONTENTS

PART 1 - GENERAL

1.01 SUMMARY AND SCOPE

- A. Applicable provisions of Division 01 – General Requirements shall govern work under this section.
- B. Perform all operations in connection with asbestos abatement, spot abatement, removal and related work as shown on drawings, specific scopes of work, and/or as specified herein.
- C. Description of Work - This specification is for the removal of the following asbestos-containing materials (ACM):

Roof penetration mastic from all three (3) buildings (M1/M2, M3 and M4). Mastic contains 4% to 5% asbestos. Material identified in the Pacific Environmental Company (PEC) survey report.

The quantities will need to be verified by the contractor.

- D. Special Precautions: Coordinate with the Owner Representative for the shutdown and isolation of all electrical circuits and air movement systems within the regulated area. Refer to Subpart entitled "3.02 Class II Asbestos Removal Work (Exterior)", of this section, relative to shutdown of mechanical and electrical systems. The provision of temporary facilities and/or utilities must be arranged prior to each project as necessary and will be the responsibility of the Contractor.
- E. Special Circumstances: Emergency response may be necessary during non-working hours requiring Contractor personnel to be on-site within a very short time frame (2 to 3 hours of notification (e.g., due to weather, vandalism, burglary, etc.)).
- F. Restoration: Not Applicable.
- G. Related work specified elsewhere (enclosed):

<u>Section Title</u>	<u>Section Number</u>
Removal and Disposal of Material Containing Lead	02 83 33
Handling of Lighting Ballasts Containing PCBs, etc.	02 84 16

1.02 REFERENCES

- A. General Reference:

All work under this contract shall be done in accordance with all applicable Federal, State, and local regulations, standards and codes governing asbestos abatement and any other trade work done in conjunction with the abatement. The most recent edition of any relevant regulation in force at the time of bid opening shall be in effect. Where conflict among the laws, rules, regulations, or with these specifications exists, the most stringent requirements shall be utilized.

- B. Specific References:

Occupational Safety and Health Administration (OSHA) Title 29 Code of Federal Regulations (CFR):
1910.134 – Respiratory Protection.

1926.1101 – Asbestos; Construction Industry
1926.59 - Hazard Communication Standard; Construction Industry

Environmental Protection Agency (EPA), Title 40 Code of Federal Regulations (CFR) Part 61 - National Emission Standards for Hazardous Air Pollutants; Asbestos NESHAP Revision; Final Rule as amended July 20, 2004.

California Division of Occupational Safety and Health (Cal/DOSH)
8 CCR 1529 – Asbestos
8 CCR 5144 – Respiratory Protection Standard
8 CCR Article 2.5, Sections 341.6 – 341.14 – Registration-Asbestos-Related Work

South Coast Air Quality Management District (SCAQMD) Rule 1403 – Asbestos Emissions from Demolition/Renovation Activities

1.03 QUALIFICATIONS

- A. The prospective Contractor shall submit to designated Owner Representative the data hereinafter requested within ten (10) days after Bid Opening.
- B. The Contractor shall, if requested:
 - 1. Demonstrate prior experience on asbestos abatement projects of similar nature and scope of that being bid through the submission of letters of reference from building owners including the name, address, and telephone numbers of the contact persons who are specifically familiar with the referenced projects. At least three previous users of this service shall be submitted. Include descriptions of projects and records of all air monitoring data that was generated during the projects.
 - 2. Submit a description of all major Asbestos Abatement Equipment owned by the prospective Contractor which is available for use on this project such as, but not limited to, respiratory protection equipment, HEPA vacuum equipment, negative air pressure equipment, spray equipment for amended water, and equipment used for shower facilities in decontamination enclosure system.
- C. The Contractor shall submit a list of names, work responsibilities and evidence of certification for all employees that will be assigned to this project.
- D. Contractor or their subcontractor is required to have appropriate State of California Contractors C-22 license to complete asbestos abatement and asbestos-related work.
- E. At least one principal, the firm's "competent person" and any other personnel performing supervisory duties must be in possession of current asbestos training documentation as an Asbestos Abatement Supervisor.
- F. Contractor or their subcontractor is required to have appropriately trained workers (32-hour class) with certifications to complete asbestos abatement and/or asbestos-related work.

1.04 DEFINITIONS

ACGIH:

American Conference of Governmental Industrial Hygienists

AIHA: American Industrial Hygiene Association

Air Monitoring:

The process of measuring the fiber content of a known volume of air collected during a specific period of time shall conform with Appendix A to OSHA 29 CFR 1926.1101. The procedure normally utilized for asbestos follows the NIOSH Standard Analytical Method 7400 for Asbestos in Air. For clearance air monitoring, electron microscopy methods may be utilized for lower detectability limit and specific fiber identification.

Air Sampling Professional:

The Professional contracted to supervise and conduct air monitoring and analysis schemes. This individual shall not be affiliated in any way other than through this contact with the Contractor performing the abatement work.

ANSI: American National Standards Institute

Asbestos:

Means the asbestiform varieties of chrysotile (serpentine); crocidolite (riebeckite); amosite (cummingtonite-grunerite); tremolite; anthophyllite, and actinolite.

Asbestos-Containing Material (ACM):

Material composed of asbestos of any type and in an amount greater than 1%, either alone or mixed with other fibrous or nonfibrous materials.

Asbestos-Containing Construction Material (ACCM):

California OSHA (Cal/OSHA) defines an ACCM as any substance containing one-tenth of one percent (0.1%) to one percent (1%) asbestos by weight.

Asbestos-Containing Waste Material:

Asbestos containing material or asbestos contaminated debris or objects requiring disposal.

ASTM:

American Society for Testing and Materials (now ASTM International)

Authorized Visitor:

The Building Owner (and designated representatives) and any representative of a regulatory agency having jurisdiction over the project.

California Division of Occupational Safety and Health (Cal/DOSH):

The Occupational Safety and Health Enforcement Section aka Cal DOSH or Cal/OSHA which is a part of the California Division of Industrial Relations.

Certified Asbestos Consultant (CAC):

An asbestos competent person registered with Cal/DOSH in accordance with 8 CCR 1529 and familiar with asbestos abatement and asbestos-related work. The CAC can design asbestos abatement projects, prepare reports, work plans and specifications.

Certified Industrial Hygienist (CIH):

An industrial hygienist certified in Comprehensive Practice by the American Board of Industrial Hygiene.

Certified Site Surveillance Technician (CSST):

An asbestos competent person registered in accordance with 8 CCR 1529 that monitors the asbestos abatement activities of others, provides asbestos air monitoring services for area and personal samples, and performs building surveys and contract administration at the direction of a Certified Asbestos Consultant.

Competent Person:

Means one who is capable of identifying existing asbestos hazards in the workplace and who has the authority to take prompt corrective measures to eliminate them.

Consultant:

Means the person, persons, and/or company contracted by the Owner to provide third party oversight of the project described in these specifications. The Consultant shall have no business relationship with the Contractor.

Contractor:

Means the person, persons, and/or company contracted by the Owner to provide the services specified herein.

Decontamination Enclosure:

A decontamination system consisting of a clean room, a shower room, and an equipment room separated from each other and from the regulated area by airlocks. This system is used for all workers to enter and exit the regulated area and may also serve as equipment and waste pass out on small jobs.

Encapsulation:

The application of a bridging or penetrating liquid material to asbestos containing materials to control the release of asbestos fibers into the air. The bridging liquid material creates a membrane over the surface and the penetrating liquid material seeps through the surface and binds all components together.

Enclosure:

The construction of an airtight, impermeable barrier around asbestos containing material to control the release of asbestos fibers into the air.

EPA: U. S. Environmental Protection Agency

Excursion Limit (EL) :

OSHA exposure limit which is 1.0 fiber per cubic centimeter of air as averaged over a sampling period of thirty (30) minutes.

Friable Asbestos-containing Material:

Any material containing more than one percent asbestos as determined using the method specified in appendix E, subpart E 40 CFR part 763, Section 1, Polarized Light Microscopy, that, when dry, can be crumbled, pulverized or reduced to powder by hand pressure.

Glovebag Technique:

A method with limited applications for removing small amounts of friable asbestos-containing material from ducts, short piping runs, valves, joints, elbows, and other nonplanar surfaces in a non-contained (plasticized) regulated area. The glovebag is constructed and installed in such a

manner that it surrounds the object or material to be removed and contains all asbestos fibers released during the process.

HEPA Filter:

A high efficiency particulate air filter capable of removing particles 0.3 microns in diameter with 99.97% efficiency.

HEPA Vacuum:

A vacuum system equipped with HEPA filtration.

NESHAP:

National Emission Standards for Hazardous Air Pollutants

Non-Friable Asbestos-containing Material:

Any material containing more than one percent asbestos as determined using the method specified in appendix E, subpart E 40 CFR part 763, Section 1, Polarized Light Microscopy, that, when dry, cannot be crumbled, pulverized or reduced to powder by hand pressure.

OSHA:

The Federal Occupational Safety and Health Administration; may also be referenced instead of Cal/DOSH or Cal/OSHA equivalent regulations.

Owner:

Means the owner of the properties in which the activities described in these specifications are to be performed for. The Owner will also be the employer of the personnel working in the affected building.

(designated) Owner Representative:

Means the person, persons, or company who monitors the work specified in this document with the Owner's interests as a priority. Compliance with these specifications will be monitored by the Owner's Representative. The Consultant and the Owner's Representative will be the same unless otherwise specified.

Permissible Exposure Limits (PELs):

No personnel associated with asbestos abatement work shall be exposed to an airborne concentration of asbestos in excess of the following limits, as determined by the method prescribed in Appendix A to OSHA 29 CFR 1926.1101, or by an equivalent method:

PEL - OSHA Permissible Exposure Limit which is 0.1 fiber per cubic centimeter of air as an eight (8)-hour time-weighted average.

Excursion Limit (EL) - OSHA exposure limit which is 1.0 fiber per cubic centimeter of air as averaged over a sampling period of thirty (30) minutes.

Regulated Area:

An area identified by specific boundaries where airborne concentrations of asbestos exceed, or can reasonably be expected to exceed, the PEL and/or Excursion Limit. The regulated area may take the form of a temporary negative-pressure enclosure, or an area specifically identified and segregated in any manner that minimizes the number of employees exposed to asbestos.

San Bernardino City Unified School District (SBCUSD):

Property Owner

San Bernardino High School (SBHS)
Project campus

South Coast Air Quality Management District (SCAQMD):

The SCAQMD is the local enforcement and notification agency within Orange, and populated portions of Los Angeles, San Bernardino and Riverside Counties in the State of California.

Surfactant:

A chemical wetting agent added to water to improve penetration.

Visible Emissions:

Any emissions containing particulate asbestos material that is visually detectable without the aid of instruments. This does not include condensed uncombined water vapor.

Wet Cleaning:

The process of eliminating asbestos contamination from building surfaces and objects by using cloths, mops, or other cleaning utensils which have been dampened with water and afterwards thoroughly decontaminated or disposed of as asbestos contaminated waste.

1.05 SUBMITTALS AND NOTICES

- A. No later than 10 days prior to commencement of work, Contractor shall submit in electronic format (PDF files) to the Owner Representative and/or Consultant documentation that includes, without limitation, the following:
1. Current copies of licenses and registrations as required by Article 1.03, Qualifications.
 2. Copies of written notification to the following regulatory agencies:
 - a. Cal/DOSH
 - b. SCAQMD
 - c. City / County of San Bernardino Permits (if applicable)
 3. Current proof of insurance coverage required by Article 1.10 Insurance Requirements (include proof of insurance for subcontractors).
 4. Current proof that required permits, site location and arrangements for transport and disposal of asbestos materials have been made.
 5. Current proof of legal right to use patented equipment or processes.
 6. Current Manufacturer's certification that HEPA vacuums, differential pressure air filtration devices and other local exhaust ventilation equipment conform to ANSI Z9.2-79 and have been permitted by the SCAQMD, as applicable.
 7. Current documentation showing that Contractor's employees, including foreman, supervisor, and any other company personnel or agents who may be exposed to airborne asbestos fibers or who may be responsible for any aspects of asbestos abatement activities, have received training as required by 29 CFR 1926.1101 and 8 CCR 1529.

8. Current documentation from Physician (signed by an M.D.) showing that all employees or agents who may be exposed to airborne asbestos fibers, and/or lead dust, in excess of background levels have received medical monitoring to determine whether they are physically capable of working while wearing the respirator required without suffering adverse health effects. The Contractor must be aware of and provide information to the examining physician about unusual conditions in the workplace environment (e.g. high temperatures, humidity, chemical contaminants) that may impact on the employee's ability to perform work activities.
 9. Current documentation of respirator fit-testing for all Contractor employees and agents who must enter the work area. This fit-testing shall be conducted annually and in accordance with procedures as required by 29 CFR 1910.134 and 8 CCR 5144.
 10. An emergency preparedness plan as required by Article 1.07 - Emergency Planning.
 11. Master schedule, showing phasing, number of shifts, time for air clearances, tear down and manpower loading to be utilized for the duration of the project.
 12. A site-specific work plan based on scope of work. Include a diagram showing containment set-up, decontamination unit(s), locations of negative air machines and exhaust placement.
 13. The name, address and telephone number of the transporter and disposal facility must be provided to the Owner.
- B. During abatement activities, Contractor shall submit to the Owner Representative and/or Consultant documentation that includes, without limitation, the following:
1. Copies of the work area entry/exit log book. Log book must record name, affiliation, time in, and time out for each entry into the work area.
 2. Copies of logs documenting filter changes on respirators, HEPA vacuums, differential pressure air filtration devices, water filtration device, and other engineering controls.
 3. Copies of Safety Data Sheets (SDS) for solvents, encapsulants, wetting agents, replacement materials, and other substances brought by Contractor to the Project Site. SDSs shall be available the first day that subject materials/substances are present on the project site.
 4. Results of all required Cal/DOSH compliance air monitoring. Results shall be available prior to the start of the following shift and within 24 hours of completion of the last shift.
 5. Copies of all accident/incident reports where injury or damage has occurred on or to the Owner's property.
 6. Copies of daily work logs indicating location(s) worked, type of materials removed, quantity of materials removed and number of personnel conducting the aforementioned activities.
 7. Copies of all transport manifests, trip tickets and disposal receipts for all asbestos, lead and universal waste materials removed from the work area shall be provided. Copies shall be emailed to the following individual(s):

Mr. Matt Fulton
Project Manager
San Bernardino City Unified School District
Facilities Planning & Management
956 West 9th Street
San Bernardino, CA 92411
Matt.fulton@sbcusd.k12.ca.us

8. Referenced documents within this section shall also be provided to the Environmental Consultants. These documents will be utilized in the generation of a Close out Report at the conclusion of the abatement activities.

1.06 SITE SECURITY

- A. Contractor shall be responsible for the security of the regulated area(s) during abatement operations in order to protect work efforts and Owner equipment. Contractor will also be responsible for the security of all their equipment and materials on the job site.
- B. The regulated area shall be restricted to only authorized, trained, and protected personnel. These may include the Contractor's employees, employees of subcontractors, State representatives, and any other designated individuals. A list of authorized personnel shall be established prior to job start and posted in the clean room of the decontamination facility. A log book shall be maintained in the clean room area of the decontamination system. Anyone who enters the regulated area must record name, affiliation, time in, and time out for each entry.
- C. Contractor shall assure any unauthorized individual entering the regulated area is decontaminated (if required), evict them, and notify the Owner Representative of the actions taken and the identity of the unauthorized individual.
- D. Access to the regulated area shall be through a single decontamination system. All other means of access (doors, windows, hallways, etc.) shall be blocked or locked so as to prevent entry to or exit from the regulated area. The only exceptions to this rule are the waste pass-out air lock which shall be sealed except during the removal of containerized asbestos waste from the regulated area, and emergency exits in case of fire or accident. Emergency exits shall not be locked from the inside. However, they shall be sealed with polyethylene sheeting and tape until needed.

1.07 EMERGENCY PLANNING

- A. Emergency procedures shall be in written form and prominently posted in the clean change area and equipment room of the worker decontamination area. Everyone prior to entering the regulated area must read and sign these procedures to acknowledge receipt and understanding of work site layout, location of emergency exits and emergency procedures.
- B. Contractor employees shall be trained in evacuation procedures in the event of workplace emergencies under the following conditions:
 1. For non-life-threatening situations, employees injured or otherwise incapacitated shall decontaminate following normal procedures with assistance from fellow workers, if necessary, before exiting the workplace to obtain proper medical treatment.

2. For life-threatening injury or illness, worker decontamination shall take least priority; after measures to stabilize the injured worker, remove the worker from the workplace and secure proper medical treatment.
- C. Telephone numbers of all emergency response personnel shall be prominently posted in the clean change area and equipment room along with the location of the nearest telephone.
- D. Exit routes should be clearly identified in the containment.
- E. Procedures to prevent and treat heat stress must be posted in the clean room area. Workers shall be provided easy access to drinking water outside of the regulated area(s) and encouraged to drink frequently.

1.08 MEETINGS

- A. Refer to Division 1.

1.09 DELIVERY, STORAGE, AND HANDLING

- A. Refer to Division 1.

1.10 INSURANCE REQUIREMENTS

- A. Refer to Division 1 and Owner and/or General Contractor insurance requirements.

1.11 BONDING REQUIREMENTS

- A. Refer to Division 1 and Owner and/or General Contractor Subcontractor Agreements.

1.12 PROJECT SCHEDULE

- A. Project Start Date: Refer to Owner and/or General Contractor's Instructions to Bidders and Published Project Schedule. Multiple notices to regulatory agencies and mobilizations will be required, as the project is phased.

PART 2 - PRODUCTS

2.01 MATERIALS

- A. Polyethylene sheeting for all uses shall be a minimum of six (6) mil thickness. Widths will be selected to minimize the frequency of joints. All plastic, spray-on strippable coatings and structural materials shall be UL-certified as fire-retardant or non-combustible.
- B. Deliver all materials in the original packages, containers, or bundles bearing the name of the manufacturer and brand name (where applicable).

- C. Polyethylene sheeting utilized for decontamination enclosure shall be opaque white or black in color and 6-mil in thickness.
- D. Disposal bags shall be of six (6) mil polyethylene, preprinted with labels as required by Cal/DOSH Requirement 8 CCR 1529 (k) (8) (C).
- E. Metal disposal bins shall be used for the storage of asbestos-containing waste materials. Bins shall be lined in plastic sheeting affixed with spray glue and tape at walls, floor and ceiling of the bin. As an alternate, disposal drums for transporting disposal bags may be used. Drums shall be metal, 55-gallon DOT A1A (DOT 17H) with locking ring tops and will meet the requirements of 49 CFR 172 – 178. Stick-on labels as per EPA and 8 CCR 1529 (k) (8) requirements shall be provided for the disposal drums.
- F. If utilized, mastic removal solvents shall not be or create a RCRA waste and shall be of the low odor variety.
- G. Surfactant (Wetting Agent) for Amended Water:
 - 1. For use with materials containing asbestos identified as "Amosite", shall be a 50/50 mixture of polyoxymethylene ether and polyoxyethylene ester, mixed in a proportion of one (1) fluid ounce to five (5) gallons of water or as specified by manufacturer.
 - 2. For all materials containing asbestos identified as "chrysotile", "crocidolite", or types other than Amosite, shall consist of soapy water mixed in a proportion of two (2) fluid ounces of liquid soap to five (5) gallons of water.
 - 3. Where regulated area temperature may cause freezing of the amended water solution, the addition of ethylene glycol in amounts sufficient to prevent freezing is permitted.
- H. Encapsulating Material:
 - 1. Bridging type encapsulant (for sealing masonry and concrete walls, barrier surfaces during cleanup phase and asbestos containing surfaces to remain in place) shall be capable of being applied with airless spray equipment, able to withstand light impact or abrasion without releasing fibers, and be water insoluble when cured.
 - 2. Penetrating type encapsulant (for sealing scratch coat plaster, wood grounds and wood blocking which have been in contact with asbestos containing material and also exposed ends of pipe insulation) shall not be noxious or toxic to applicator or subsequent occupants, shall have high flame retardance and low toxic fume and smoke emission ratings, and shall have some permeability to water vapor to prevent condensation accumulation.
 - 3. Encapsulants shall be applied using airless spray equipment or hand pressurized sprayer.

2.02 EQUIPMENT

A. Negative Pressure Ventilation Units (Use as applicable):

This project is for the abatement of roof penetration mastic; therefore, no negative pressure units necessary. This has only been left in the specification for completeness and possible use if the need arises.

1. A sufficient quantity of negative pressure ventilation units equipped with HEPA filtration and operated in accordance with ANSI and EPA guidance documents. They shall be utilized so as to provide one workplace air change every 15 minutes.

To calculate total air flow requirement:

$$\text{Total Ft}^3/\text{Min.} = \frac{\text{Volume of Regulated area (in Ft}^3\text{)}}{15 \text{ Min.}}$$

To calculate the number of units needed for the abatement:

$$\text{Number of Units Needed} = \frac{\text{Total Ft}^3/\text{Min.}}{0.75(\text{Capacity of Unit in Ft}^3/\text{Min.})}$$

2. The air filtering equipment shall be capable of filtering asbestos fibers at 0.3 um at 99.97 percent efficiency. Pre-filters, which protect the final filter by removing the larger particles, are required to prolong the operating life of the HEPA filter. Two stages of pre-filtration are required. The first-stage pre-filter shall be a low efficiency type (e.g., for particles 10 um and larger). The second-stage (or intermediate) filter shall have a medium efficiency (e.g., effective for particles down to 5 um). Pre-filters and intermediate filters shall be installed either on or in the intake grid of the unit and held in place with special housings or clamps.
 3. The exhaust air for the air filtering devices used to maintain negative pressure in the contained regulated area(s) shall be directed outdoors to an area where unprotected personnel are not present.
 4. The regulated area shall be maintained at a negative pressure of -0.02 inches of water (head). The ventilation shall operate on a 24-hour basis throughout the abatement process until final clearance has been approved.
- B. Air Purifying Respirators: Respirator bodies shall be of half face or full-face type with removable cartridges. Single use, disposable or quarter face respirators shall not be used. Full face respirators shall be equipped with a nose cup or other anti-fogging devices as would be appropriate for use in air temperatures less than 32 degrees F. Filter cartridges shall, at a minimum, be HEPA type filters certified by NIOSH under 30 CFR Part 11 or with filters certified for particulates under 42 CFR Part 84 (e.g., P100).
- C. Full body disposable protective clothing, including head, body and foot coverings consisting of material impenetrable by asbestos fibers (Tyvek® or equivalent) shall be provided to all workers and authorized visitors in sizes adequate to accommodate movement without tearing.
1. Full body disposable protective clothing as described above shall be provided to authorized visitors in sizes adequate to accommodate movement without tearing on request.

- D. Additional safety equipment (as necessary), such as hard hats, eye protection, safety shoes, disposable gloves meeting the requirements of current ANSI Standards shall be provided to all workers and authorized visitors. Nonskid footwear shall be provided to all abatement workers. Disposable clothing shall be adequately sealed to the footwear and gloves to prevent body contamination.
- E. Provide sufficient supply of disposable mops, rags and sponges for work area decontamination. Rubber dust pans and rubber squeegees shall be provided for cleanup.
- F. Provide scaffolds, ladders, lifts and hand tools such as scrapers, wire cutters, brushes, utility knives, and wire saws, as the work requires. Brushes utilized for removing loose asbestos containing material shall have nylon or fiber bristles, not metal.
 - 1. Contractor must have in place a valid Fall Protection Plan, in compliance with Cal/DOSH requirements, to be reviewed and approved by the designated Owner Representative.
- G. Sprayers shall have pumps capable of providing 14-15 pounds per square inch (psi) at the nozzle tip at a flow rate of 2 gallons per minute for spraying amended water.
- H. A sufficient supply of HEPA filtered vacuum systems shall be available during cleanup.
- I. Airless spray equipment with an adjustable low-pressure nozzle shall be provided for spraying wetting agents and encapsulants. Nozzle tip size and pressure adjustment shall conform to encapsulant manufacturer's written recommendations.
- J. Heavy duty power cables for temporary electrical service and a portable electric generator for maintaining negative pressure in the work area in case of power failure.
- K. Warning Signs and Labels: As required OSHA Regulation 29 CFR 1926.1101(k) and 8 CCR 1529 (k).
- L. Other equipment the Contractor deems necessary for asbestos abatement work shall be submitted to the designated Owner Representative and/or Consultant for approval prior to their use.

PART 3 EXECUTION

3.01 GENERAL COMPLIANCE MEASURES

- A. Mandatory Protection Conditions: Contractor's employees shall wear appropriate respiratory protection and protective clothing under the following conditions:
 - 1. During installation or implementation of engineering work practices and control measures.
 - 2. During maintenance and repair activities for which control measures, hereinafter described, are not feasible.
 - 3. Whenever the control measures are not yet sufficient to reduce exposure below the Permissible Exposure Limits (TWA and/or Excursion Limits).

4. Whenever emergency conditions exist.
- B. Control Measures: The Contractor shall use one or any combination of the following control methods to achieve compliance with the "Permissible Exposure Limits" defined herein:
1. Local exhaust ventilation equipped with HEPA filter dust collection systems (as referenced in 2.02.).
 2. General dilution ventilation equipped with HEPA filtration systems on both exhaust and return air (as referenced in 2.02.).
 3. Vacuum cleaners equipped with HEPA filters (as referenced in 2.02.).
 4. Enclosure or isolation of processes producing airborne asbestos fibers and dust.
 5. Use of wet methods, wetting agents or removal encapsulants to control employee exposures during their performance of asbestos abatement activities. Where wet methods would result in equipment damage or a safety hazard, dry removal is allowed with written approval from Cal/DOSH, SCAQMD and the designated Owner Representative.
 6. Prompt clean up and disposal of wastes contaminated with asbestos in leak-tight containers.
- C. Supplement to Control Measures: Whenever the control measures described above are not sufficient to reduce the employee exposure to or below the "Permissible Exposure Limits" (TWA and/or Excursion Limit), the Contractor shall continue to use the control measures to maintain the employee exposure to the lowest levels attainable and supplement them with the use of appropriate respiratory protection and protective clothing.
- D. Negative-Pressure Enclosure: A negative-pressure enclosure shall be employed whenever feasible, prior to commencing removal, demolition and renovation operations involving asbestos containing materials. The negative air machines should be ducted outdoors, especially if the space outside the containment is occupied. This will prevent the indoor spread of contamination if the negative air machine malfunctions or other chemicals are used in the containment (not recommended) which would not be filtered by the machines. If the area of work outside is dusty, then a square hole may be cut in the containment and fitted with a pleated residential air filter (Minimum Efficiency Reporting Value [MERV] 11 or better) to filter the make-up air. The entry to the containment should be well sealed to prevent the entry of unfiltered outside air.
- E. Types of Respiratory Protection: The following Table represents the minimum respiratory protection required for given airborne concentrations of asbestos:

Airborne Concentration of Asbestos	Required Respirator
Not in excess of 1 f/cc (10x PEL)	Half-mask air purifying respirator equipped with high-efficiency filters
Not in excess of 5 f/cc (50x PEL)	Full face piece air purifying respirator equipped with high-efficiency filters (quantitatively fit tested)
Not in excess of 10 f/cc (100x PEL)	<ol style="list-style-type: none"> 1. Any powered air purifying respirator equipped with high efficiency filters or 2. Any supplied air respirator operated in continuous flow mode.

Airborne Concentration of Asbestos	Required Respirator
Not in excess of 100 f/cc (1000x PEL)	Full face piece supplied air respirator operated in pressure demand mode.
Greater than 100 f/cc (1,000x PEL) or an unknown concentration	Full face piece supplied air respirator operated in pressure demand mode equipped with an auxiliary positive pressure self-contained breathing apparatus.

NOTE: Respirators assigned for higher environmental concentrations may be used at lower concentrations. A high-efficiency filter means a filter that is at least 99.97 percent efficient against mono-dispersed particles of 0.3 micrometers in diameter or larger.

- F. For all OSHA Class I work, a Powered Air Purifying Respirator (PAPR) or Supplied Air Respirator (SAR) shall be used until initial air monitoring determines that the OSHA PEL and EL will not be exceeded, at which point a half mask or full face respirator may be used for the remainder of the project.
- G. Employee Rotation: The Contractor shall not use employee rotation as a means of compliance with Permissible Exposure Limits (TWA and/or Excursion Limit).
- H. Supervision: The Contractor shall have a bilingual (usually English and Spanish) licensed project supervisor on site at all times that only supervises the project and is responsible to assure contract and regulatory compliance. He/she shall have a mobile phone available 24 hours per day with the number provided to the designated Owner Representative(s) identified during the pre-construction meeting.

3.02 Class II Asbestos Removal Work (Exterior)

The following procedure shall be utilized for all removal of non-friable/Class II exterior materials, such as roof mastics.

- A. Contractor shall coordinate all items of work with the Project Environmental Consultant.
- B. Contractor shall shut down and lock out all heating, cooling, and air conditioning system (HVAC) components that are in supply or pass through the work area. In the event that there is any impact to the HVAC system (such as a fresh air intake), the HVAC system shall remain off during the project.
- C. Contractor shall shut down and lock out electric power to all Work Areas. Contractor shall provide temporary power and lighting sources, ensure safe installation of temporary power sources and equipment by compliance with all applicable electrical code requirements and Cal/OSHA requirements for temporary electrical systems. Protect each circuit with a Ground Fault Circuit Interrupter (GFCI) of proper size located in the temporary panel.
- D. Contractor shall establish a regulated area around the perimeter of the designated work area. At a minimum, the regulated area shall consist of barrier tape and delineators at sufficient distance from the work area so that debris does not fall outside of the regulated area based on current conditions at the site. The barrier tape may contain appropriate wording such as "DANGER ASBESTOS". Appropriate signage and a worker decontamination unit shall be included, and part of the regulated area (see below).
- E. Install worker decontamination unit described in Article 3.03 or as agreed upon with Project Environmental Consultant. Installation shall occur as close to the designated work area as possible, with polyethylene sheeting laid down between the decontamination unit and the work area access.

- F. Post warning signs meeting the specifications of 8 CCR 1529, 8 CCR 5208, and 29 CFR 1926.1101, at any location and approaches to a location where airborne concentration of asbestos fibers may exceed ambient background levels. Signs shall be posted at a distance sufficiently far enough away from a work area to permit a person to read the sign and take necessary protective measures to avoid exposure.
- G. Asbestos Handlers shall don personnel protective equipment as required in Article 2.02. Double-suiting is recommended if decontamination unit is not on roof.
- H. Pre-clean all vertical and horizontal surfaces within the work area using HEPA-filtered vacuum and/or wet cleaning techniques, as appropriate. This may include HVAC duct work and equipment only; there is no need to pre-clean surfaces to be removed. Contractor shall not use methods that would raise dust, such as dry sweeping or vacuuming with equipment not equipped with HEPA filters and shall not disturb asbestos-containing materials during the pre-cleaning phase.
- H. Seal off all windows, doorways, drains, ducts, and any other openings between the Work Area and uncontaminated areas outside of the Work Area with six-mil fire retardant polyethylene sheeting and tape. Walls with mortar joints (e.g., tile) are considered porous. Openings through these walls must be sealed by critical barriers.
- I. As applicable to field conditions, place 6-mil plastic sheeting at the base of building underneath the work area and fasten to the building wall with tape to catch debris that may be generated during abatement or be dislodged from windows or fire doors during abatement. At a minimum, plastic sheeting shall be placed 10 feet out from the work area but must remain inside the regulated area. The regulated area and plastic sheeting may need to be extended based on site conditions at the time of abatement.
- J. The Contractor shall carry out all asbestos removal activities in a manner that will minimize pulverizing, breaking or creation of dust. Only manual removal methods will be performed under this Specification. Mechanical removal methods MUST be submitted in writing and approved by Owner Representatives under Alternative Procedures (see Article 3.15).
- K. Keep the ACMs being removed wet throughout removal operations. In the event that visible dust is generated during the abatement process, also mist the air within regulated area periodically to reduce airborne asbestos fiber concentrations.

Bags of asbestos waste shall not be dropped or thrown, but carefully lowered to the ground surface. If chutes are utilized, the chutes shall be completely sealed in poly sheeting.
- L. Once all removal activities have been completed, clean-up of the work areas shall be conducted in accordance with Article 3.10 - Clean-Up Procedures.
- M. Encapsulate entire work area with a penetrating and/or lock-down type encapsulant following acceptance of clean-up activities.
- N. Dispose of all asbestos containing/contaminated waste in accordance with Article 3.13 - Disposal Procedures.

3.03 DECONTAMINATION ENCLOSURE SYSTEM

- A. Worker decontamination enclosure systems shall be provided at all locations where workers will enter or exit the work area. At a minimum, one, three-stage system at a single location is preferred. Each work area where negative pressure enclosure is the selected method of engineering controls shall have a worker decontamination unit.

In the event that a three-stage decontamination unit includes a shower, the shower must be connected to a water source and have a water filtration unit attached and functioning. As an alternate, a cleansing station may be used. See Item E below.

- B. Worker decontamination enclosure systems constructed at the Project site shall utilize six-mil, fire-retardant polyethylene sheeting, or other approved materials for privacy.
- C. Personnel Decontamination Units shall not be located inside the work area(s) unless specifically authorized by the Project Environmental Consultant.
- D. Alternate methods of providing Decontamination facilities may be submitted to the Project Environmental Consultant for approval. Do not proceed with any such method(s) without the written authorization from designated Owner Representative and/or Consultant.
- E. The worker decontamination enclosure system shall consist of at least a cleansing station in accordance with the requirements of 8 CCR 1527 and 8 CCR 1529, equipped with adequate water, towels and cleansing agents to accommodate the entire crew and visitors.
- F. All polyethylene barriers and decontamination enclosure systems shall be inspected at least twice daily by the Contractor's competent person prior to the start of each day's abatement activities and following the completion of the day's abatement activities.
- G. Damage and defects in the enclosure system are to be repaired immediately upon discovery.

3.04 WORKPLACE ENTRY AND EXIT PROCEDURES

- A. All workers and authorized personnel shall enter the regulated area through the decontamination enclosure system.
- B. All personnel shall proceed first to the clean room, remove all street clothes, and appropriately don respiratory protection (as approved for the job conditions) and disposable coveralls, head covering and foot covering. Hard hats, eye protection and gloves shall also be utilized, if required. Clean respirators and protective clothing shall be provided and utilized by each person for each separate entry into the regulated area.
- C. Personnel wearing designated personal protective equipment shall proceed from the clean room through the decontamination enclosure system to the regulated area.
- D. Before leaving the regulated area, all personnel shall remove gross contamination from the outside of respirators and protective clothing by brushing or wet wiping procedures. Small HEPA vacuums with brush attachments may be utilized for this purpose. Each person shall clean bottoms of protective footwear in the walk-off pan just prior to entering the equipment room/pre-shower chamber.
- E. Personnel shall proceed to equipment room where they remove all protective equipment except respirators. Deposit disposable clothing into appropriately labeled containers for disposal.
- F. Reusable, contaminated footwear shall be stored in the equipment room when not in use in the regulated area. Upon completion of abatement, it shall be disposed of as asbestos contaminated waste. Rubber boots may be decontaminated at the completion of the abatement for reuse.

- G. Workers will decontaminate all respirators and non-porous items with wet towels, rags provided in the equipment room. Workers will remove filter cartridges and dispose of them in the bag or receptacle provided in the equipment room. Workers will also wet wipe and decontaminate themselves in this location. Contaminated towels and suits shall be placed in bags/receptacles before proceeding to the clean room.
- H. Workers shall not eat, drink, smoke, and chew gum or tobacco in the regulated area. To eat, drink or smoke, workers shall follow the procedure described above, and then dress in street clothes before entering the non-regulated areas of the building.
- I. Emergency exits shall be established and clearly marked with duct tape arrows or other effective designations to permit easy location from anywhere within the regulated area. They shall be secured to prevent access from uncontaminated areas, but still permit emergency exiting. These exits shall be properly sealed with polyethylene sheeting which can be cut to permit egress, if needed. These exits may be through the decontamination enclosure, the waste pass-out airlock, and/or other alternative exits that are satisfactory to fire officials.

3.05 WASTE CONTAINER PASS-OUT PROCEDURE

- A. Asbestos contaminated waste that has been containerized shall be transported out of the regulated area through the waste container pass-out airlock (or through the decontamination enclosure if a separate airlock has not been constructed). Wherever possible, this shall be located where there is direct access from the regulated area to the outside of the building and the waste storage/disposal container. The waste container pass-out airlock shall be constructed in similar fashion to the worker decontamination enclosure system using similar materials and airlock and curtain doorway designs. This airlock system shall not be used to enter or exit the regulated area. The airlock system shall be tightly sealed when not in use.
- B. The inside team wearing protective clothing and respirators appropriate for the contaminated regulated area shall clean the entire surface, including bottoms, of properly labeled bags, using HEPA vacuums and wet wiping techniques and transport them into the waste container pass-out airlock where they will be placed into another properly labeled bag. No worker from the inside team shall further exit the regulated area through this airlock.
- C. Workers from outside the regulated area wearing appropriately assigned respirators shall enter the airlock from outside the regulated area solely for waste removal from the work area. No worker from the outside team shall further enter the regulated area through this airlock.
- D. The exit from this airlock shall be secured to prevent unauthorized entry when not in use.
- E. Asbestos waste bags and wrapped waste shall contain or have affixed a waste generator ID label or sticker.

3.06 WATER COLLECTION AND DISPOSAL

- A. All water collected from pre-cleaning or wetting activities during abatement shall be collected and disposed of as ACM waste. No water shall be disposed of in sanitary sewers or storm drains.

3.07 WET REMOVAL PROCEDURE

- A. All non-friable asbestos waste shall be disposed of as Non-Hazardous, Non-Friable Asbestos Waste.
- B. Wet all asbestos containing material with an amended water solution using equipment capable of providing a fine spray mist, in order to reduce airborne fiber concentrations when the material is disturbed. Saturate the material to the substrate. Keep all removed material wet to prevent fiber release until it can be containerized for disposal.
- C. Saturated asbestos containing material shall be removed in manageable sections, but as large as practical. Removed material should be containerized before moving to a new location for continuance of work. Surrounding areas shall be periodically sprayed and maintained in a wet condition until visible material is cleaned up.
- D. Bags shall be considered full when half their capacity has been filled. They should be securely sealed to prevent accidental opening and leakage by tying tops of bags in an overhand knot or by taping in gooseneck fashion. Do not seal bags with wire or cord.
- E. Large components removed intact may be wrapped in two (2) layers of six (6) mil polyethylene sheeting secured with tape for transport to the approved disposal site, and labeled.
- F. Asbestos containing waste with sharp edged components (e.g., nails, screws, metal lathe, tin sheeting) shall be placed into drums for disposal in lieu of polyethylene bags. Drums shall be marked to differentiate contents from those drums containing bagged material.
- G. After completion of all stripping work, surfaces from which asbestos containing materials have been removed such as plaster base coat or metal deck, etc., the surfaces shall be wet brushed and sponged to remove all visible residues.

3.08 AIR MONITORING

- A. Area air samples may be collected by the Environmental Consultant during portions of the abatement (i.e., beginning, middle, and end) with high volume pumps having a capacity of up to 10 liters per minute. These samples shall be of sufficient time and quantity to characterize asbestos emissions inside and outside of containment and on the perimeter of the project. The criteria of acceptability will be ≤ 0.01 f/cc. If the criteria is not met the Contractor will conduct corrective actions, as necessary. This does not include personnel air samples, which will be collected by abatement contractor.
- B. Air samples collected by Environmental Consultants will be analyzed by an accredited laboratory accredited, or by a NIOSH equivalent trained microscopist on-site. Results of each analysis shall be submitted to the Owner Representative for the record. Copies of the analysis results shall also be made available to the Owner, Contractor and the Owner's Representative upon request.

3.09 WORK STOPPAGE

- A. The Owner's Representative has the authority to stop the abatement work under the provisions of the General Conditions of this contract at any time he/she determines either personally or through the services of the air sampling professional that conditions are not in compliance with the specifications and applicable regulations. The stoppage of work shall continue until conditions have been corrected and corrective steps have been taken to the satisfaction of the Owner's Representative. Standby time required to resolve violations shall be at the Contractor's expense.

3.10 CLEANUP PROCEDURE

- A. Remove and containerize all visible accumulations of asbestos containing material and asbestos contaminated debris utilizing rubber dust pans and rubber squeegees to move material around. Do not use metal shovels to pick up or move accumulated waste. Special care shall be taken to minimize damage to floor containment sheeting, when present.
- B. Wet clean all surfaces in the regulated area using rags, mops and sponges as appropriate. (Note: Some HEPA vacuums might not be wet-dry vacuums.)
- C. Prior to removing the inner layer of plastic sheeting, the sheeting shall be sprayed with an encapsulant so that any residue remaining will be adhered to the plastic sheeting.
- D. Remove the cleaned inner layer of plastic sheeting from walls and floors. Windows, doors, HVAC system vents and all other openings shall remain sealed. The negative pressure ventilation units shall remain in continuous operation. Decontamination enclosure systems shall remain in place and be utilized.
- E. Remove all containerized waste from the regulated area and waste container pass-out airlock. Decontaminate all tools and equipment and remove at the appropriate time in the cleaning sequence.
- F. The Owner's Representative and the Contractor shall inspect the regulated area for visible residue. If any accumulation of residue is observed, it will be assumed to be asbestos and the cleaning cycle shall be repeated.

3.11 CLEARANCE TESTING

The exterior abatement locations will be cleared by visual inspection although area air samples for analysis by PCM will be collected at the perimeters of the regulated areas.

3.12 REESTABLISHMENT OF THE WORK AREAS

- A. Reestablishment of the work area shall only occur following the completion of clean-up procedures and after visual clearance has been performed and documented to the satisfaction of the Owner Representative or Environmental Consultant.
- B. Contractor and Owner Representative or Environmental Consultant shall visually inspect the work area for any remaining visible residue. Evidence of contamination will necessitate additional cleaning and air monitoring requirements at no additional cost to Owner, until approved by Environmental Consultant.
- C. Upon approval by Owner Representative or Environmental Consultant, the Contractor shall remove remaining fire-retardant polyethylene sheeting, critical barriers, and decontamination unit.
- D. Repair all areas of damage that occurred as a result of abatement activities at no additional cost to Owner, unless other arrangements and written approval have been provided by the Owner.

3.13 DISPOSAL PROCEDURES

- A. As the work progresses, to prevent exceeding available storage capacity on site, sealed and labeled containers of asbestos-containing waste shall be removed and transported directly to the prearranged disposal location, which must be an authorized site in accordance with regulatory requirements of NESHAP and other local authorities. Use of intermediate storage locations is not an accepted disposal procedure. Mark vehicles used to transport asbestos-containing waste in accordance with Federal, State, and local regulations. All waste containers will be supplied by the Contractor. There shall be no evidence of liquid leakage from the containers at any time.
- B. The Contractor shall provide documentation in the form of a transportation and disposal manifest that will provide a chain-of-custody record of all asbestos-containing waste from project site to the disposal site. All asbestos-containing waste generated must be accounted for by these records and copies of all such records shall be delivered to the designated Owner Representative. Shipping papers and/or manifests will be signed by the designated Owner Representative who will be provided copies of all disposal records.
- C. As necessary, obtain EPA Hazardous Waste Generator ID number from the Owner.
- D. Transportation to the Landfill:
 - 1. Contractor shall provide an enclosed lockable waste container, consisting of a truck, trailer or dumpster, for storage and transportation of waste. The waste container shall be locked while unattended and during transportation of waste. Once bags have been removed from the regulated area, they shall be loaded directly into the waste container for transportation.
 - 2. The waste container shall be free of debris and lined with six (6) mil polyethylene sheeting to prevent contamination from leaking or spilled containers. Floor sheeting shall be installed first and extend up the side walls. Wall sheeting shall be overlapped and taped into place.
 - 3. Drums shall be placed on level surfaces in the waste container and packed tightly together to prevent shifting and tipping. Large components shall be secured to prevent shifting and bags placed on top. Do not throw containers into waste container.
 - 4. Personnel loading asbestos containing waste shall be protected by disposable clothing including head, body and foot protection and at a minimum, half-facepiece, air-purifying, dual cartridge respirators equipped with HEPA filters.
 - 5. Any debris or residue observed on containers or surfaces outside of the regulated area resulting from cleanup or disposal activities shall be immediately cleaned up using HEPA filtered vacuum equipment and/or wet methods.
 - 6. Following the removal of all containerized waste, the truck cargo area shall be decontaminated using HEPA vacuums and wet methods to meet the no visible residue criteria. Polyethylene sheeting shall be removed and discarded along with contaminated cleaning materials and protective clothing in bags or drums at the disposal site.

3.14 OSHA PERSONNEL AIR MONITORING

- A. Air monitoring required by OSHA is the responsibility of the contractor. The contractor is responsible for providing daily OSHA compliance monitoring as per 29 CFR 1926.1101, 8 CCR 1529 for asbestos.
 - 1. At minimum, Contractor shall conduct representative (25% of crew) breathing zone personal air monitoring of its employees twice each shift (asbestos only) and repeated daily or until a "negative exposure assessment", as derived in accordance with 29 CFR 1926.1101 (f)(2)(iii) and 8 CCR 1529 for asbestos.
 - 2. Monitoring shall be conducted by a qualified air professional experienced and knowledgeable about the methods of air monitoring and in accordance with 29 CFR 1926.1101, 8 CCR 1529.
 - 3. Monitoring results and appropriate laboratory analysis work shall be submitted to Owner and Project Environmental Consultant within 24 hours of when the samples were collected.

3.15 ALTERNATIVE PROCEDURES

- A. If specified procedures cannot be utilized, a request shall be made in writing to the designated Owner Representative providing details of the problem encountered and recommended alternatives.
- B. Alternative procedures shall provide equivalent or greater protection than procedures that are replaced.
- C. Any alternative procedure must be approved in writing by the Owner Representative prior to the implementation of the procedure.

END OF SECTION

Abatement Specifications - Lead

**San Bernardino High School
Classroom Buildings M1/M2, M3, and M4
1850 North E Street
San Bernardino, California**

Prepared For:

**San Bernardino City Unified School District
956 West 9th Street
San Bernardino, California 92411**

Prepared By:

**Converse Consultants
717 South Myrtle Avenue
Monrovia, California 91016
Converse Project No. 18-16-106-04**

July 14 , 2021

SECTION 02 83 33

REMOVAL AND DISPOSAL OF MATERIALS CONTAINING LEAD

Revision 00

CONTENTS

PART 1 – GENERAL

- .01 Summary and Scope
- .02 References
- .03 Qualifications
- .04 Definitions
- .05 Submittals and Notices
- .06 Site Security
- .07 Emergency Planning
- .08 Meetings
- .09 Delivery, Storage and Handling
- .10 Insurance Requirements
- .11 Bonding Requirements
- .12 Project Schedule

PART 2- PRODUCTS

- .01 Materials
- .02 Equipment

PART 3 - EXECUTION

- .01 General Compliance Measures
- .02 LBP/Lead-Containing Surface Coating Impacts
- .03 Surface Preparation – LBP Stabilization
- .04 Decontamination Enclosure System
- .05 Workplace Entry and Exit Procedures
- .06 Waste Container Pass-Out Procedure
- .07 Water Collection and Disposal
- .08 Wet Removal Procedure
- .09 Encapsulation/Stabilization Procedures
- .10 Air Monitoring
- .11 Work Stoppage
- .12 Cleanup Procedure
- .13 Clearance Testing
- .14 Disposal Procedures
- .15 Alternative Procedures

END OF CONTENTS

PART 1 GENERAL

1.01 SUMMARY AND SCOPE

- A. Applicable provisions of Division 1 – General Requirements shall govern work under this section.
- B. Perform all operations in connection with lead abatement, removal, clean-up and related work as shown on drawings, specific scopes of work, and/or specified herein.
- C. Description of Work – This project involves removal, stabilization, encapsulation, and/or coating of building materials with lead-containing materials including paints; this specification is for removal or stabilization/encapsulation of the following materials:

General LBP Colors and Components

Building	Interior Component & LBP Color	Exterior Component & LBP Color
M1 and M2	Cream wall support frames and beams	Cream and walls and arcade
	Grey ceramic tiles	Black support poles
M3	Cream ceiling beams, door and door frame, window frame and window hatch	Grey parapet cap
	Grey doors and door frames, wall, electrical conduits, and support columns	Black, cream and red fascia
		Black door frame
M4	Cream door frames and roof support beam	White sink
		Red fascia
	Grey walls,	Brown door frame

Although other painted surfaces tested did not meet the criteria for LBP, concentrations of lead were detected in these other materials. Title 8 CCR 1532.1 (Cal/DOSH Lead) may require workers that perform either manual demolition or manual scraping or sanding of painted surfaces to undergo an exposure assessment including air monitoring of the breathing zone and be properly trained and protected per the Cal/DOSH lead regulation. Contractor shall be responsible for monitoring of worker exposure to lead during disturbance of painted and ceramic surfaces.

- C. Special Precautions: Coordinate with the Owner Representative for the shutdown and isolation of all electrical circuits and air movement systems within the regulated area. Refer to Subpart entitled "3.02 LBP/Lead-containing Surface Coating Impacts and 3.03 Surface Preparation-LBP Stabilization", of this section, relative to shutdown of mechanical and electrical systems. The provision of temporary facilities and/or utilities must be arranged prior to each project as necessary and will be the responsibility of the Contractor.
- D. Special Circumstances: Emergency response may be necessary during non-working hours requiring Contractor personnel to be on-site within 3 hours of notification (e.g., due to weather, vandalism, burglary, etc.).
- E. Restoration: Not Applicable.
- F. Related work specified elsewhere (enclosed):

<u>Section Title</u>	<u>Section Number</u>
Removal and Disposal of Asbestos Materials	02 82 13
Handling of Lighting Ballasts Containing PCBs, etc.	02 84 16

1.02 REFERENCES

A. General Reference:

All work under this contract shall be done in accordance with all applicable Federal, State, and local regulations, standards and codes governing asbestos abatement and any other trade work done in conjunction with the abatement. The most recent edition of any relevant regulation in force at the time of bid opening shall be in effect. Where conflict among the laws, rules, regulations, or with these specifications exists, the most stringent requirements shall be utilized.

B. Specific References:

Occupational Safety and Health Administration (OSHA) Title 29 Code of Federal Regulations (CFR):

1910.134 – Respiratory Protection.

1926.59 - Hazard Communication Standard; Construction Industry

1926.62 – Lead; Construction Industry

Environmental Protection Agency (EPA) Title 40 Code of Federal Regulations (CFR) Part 745 -- Lead-Based Paint Poisoning Prevention in Certain Residential Structures.

California Division of Occupational Safety and Health (Cal/DOSH):

8 CCR 5144 – Respiratory Protection Standard

8 CCR 1532.1 – Lead

22 CCR Division 4.5, Environmental Health Standards for the Management of Hazardous Waste

Housing and Urban Development (HUD) Guidelines for the Evaluation and Control of Lead-Based Paint Hazards in Housing.

1.03 QUALIFICATIONS

A. The prospective Contractor shall submit to the Owner Representative the data hereinafter requested within ten (10) days after Bid Opening.

B. The Contractor shall, if requested:

1. Demonstrate prior experience on lead abatement projects of similar nature and scope of that being bid, through the submission of letters of reference from building owners including the name, address, and telephone numbers of the contact persons who are specifically familiar with the referenced projects. At least three previous users of this service shall be submitted. Include descriptions of projects and records of all air monitoring data that was generated during the projects.

2. Submit a description of all major Lead Abatement Equipment owned by the prospective Contractor which is available for use on this project such as respiratory protection equipment, HEPA vacuum equipment dedicated to lead abatement, negative air pressure equipment dedicated to lead abatement, spray equipment for amended water and other coatings, equipment used for shower facilities in decontamination enclosure system.

C. Submit a list of names, work responsibilities and evidence of certification for all employees that will be assigned to this project including:

1. All removal and disturbance of LBPs and lead-containing materials shall be performed by a state-licensed contractor, using California Department of Public Health (CDPH) certified workers with at least one CDPH-certified Supervisor. All removal and disturbance of lead-containing materials (not meeting the definition of lead-based) as defined in 8 CCR 1532.1, shall be performed by a state-licensed contractor, using lead-trained workers with certification of training meeting the requirements of 8 CCR 1532.1. Abatement contractor's workforce shall be supervised by experienced persons trained, knowledgeable and qualified in the techniques of lead abatement, handling and disposal
- D. The Contractor must be licensed by the California State Contractors License Board for activities necessary to complete the projects described in this specification.

1.04 DEFINITIONS

ACGIH:

American Conference of Governmental Industrial Hygienists

AIHA: American Industrial Hygiene Association

Air Monitoring:

The process of measuring lead concentration of a known volume of air collected during a specific period of time shall conform to the requirements of OSHA Standard 29 CFR 1926.62 or 8 CCR 1532.1.

Air Sampling Professional:

The Professional contracted or employed by Owner Representative to supervise and conduct air monitoring and analysis schemes. This individual shall not be affiliated in any way other than through this contact with the Contractor performing the abatement work.

ANSI: American National Standards Institute

ASTM:

American Society for Testing and Materials (now ASTM International)

Authorized Visitor:

The Building Owner (and designated representatives) and any representative of a regulatory agency having jurisdiction over the project.

California Department of Public Health (CDPH):

Certification agency for lead abatement workers, supervisors, inspector/assessors, project monitors and sampling technicians. Lead workers and supervisors must hold current certifications with this agency. CDPH is also the enforcement agency for lead abatement in child-occupied structures.

California Division of Occupational Safety and Health (Cal/DOSH):

The Occupational Safety and Health Enforcement Section aka Cal DOSH or Cal/OSHA which is a part of the California Division of Industrial Relations.

Certified Industrial Hygienist (CIH):

An industrial hygienist certified in Comprehensive Practice by the American Board of Industrial Hygiene.

Competent Person:

Means one who is capable of identifying existing lead hazards in the workplace and who has the authority to take prompt corrective measures to eliminate them.

Consultant:

Means the person, persons, and/or company contracted by the Owner to provide third party oversight of the project described in these specifications. The Consultant shall have no business relationship with the Contractor.

Contractor:

Means the person, persons, and/or company contracted by the Owner to provide the services specified herein.

Decontamination Enclosure:

A decontamination system consisting of a clean room, a shower room, and an equipment room separated from each other and from the regulated area by airlocks. This system is used for all workers to enter and exit the regulated area and may also serve as equipment and waste pass out on small jobs.

Encapsulation:

The application of a bridging or penetrating liquid material to asbestos containing materials to control the release of lead dust into the air. The bridging liquid material creates a membrane over the surface and the penetrating liquid material seeps through the surface and binds all components together.

Enclosure:

The construction of an airtight, impermeable, permanent barrier around asbestos containing material to control the release of lead dust into the air.

EPA: U. S. Environmental Protection Agency

HEPA Filter:

A high efficiency particulate air filter capable of removing particles 0.3 microns in diameter with 99.97% efficiency.

HEPA Vacuum:

A vacuum system equipped with HEPA filtration.

Lead-Based Paint:

Paint or other surface coatings that contain lead equal to or in excess of 1.0 milligrams per square centimeter or more than 5,000 parts per million.

Lead Containing Material (LCM):

Material containing lead of any type and in an amount greater than the detection limit of the analytical method.

Lead Containing Waste Material:

Lead containing material or lead contaminated materials requiring disposal in an EPA approved landfill.

OSHA:

The Occupational Safety and Health Administration; may also be referenced instead of Cal/DOSH or Cal/OSHA equivalent regulations.

Owner:

Means the owner of the properties in which the activities described in these specifications are to be performed for. The Owner will also be the employer of the personnel working in the affected building.

(designated) Owner Representative:

Means the person, persons, or company who monitors the work specified in this document with the Owner's interests as a priority. Compliance with these specifications will be monitored by the Owner's Representative. The Consultant and the Owner's Representative will be the same unless otherwise specified.

Permissible Exposure Limits (PELs):

No personnel associated with lead abatement work shall be exposed to an airborne concentration of lead in excess of the following limits, as determined by the method prescribed in OSHA 29 CFR 1926.62, and 8 CCR 1532.1 or by an equivalent method:

PEL is 50 micrograms per cubic meter ($\mu\text{g}/\text{M}^3$) of air as an eight (8) hour time-weighted average (TWA).

Action Level is 30 $\mu\text{g}/\text{M}^3$ as an eight (8) - hour TWA.

Regulated Area:

An area identified by specific boundaries where airborne concentrations of asbestos exceed, or can reasonably be expected to exceed, the PEL and/or Excursion Limit. The regulated area may take the form of a temporary negative-pressure enclosure, or an area specifically identified and segregated in any manner that minimizes the number of employees exposed to lead dust.

Soluble Threshold Limit Concentration (STLC):

Laboratory test to be conducted on waste to determine if it meets the definition of hazardous waste.

South Coast Air Quality Management District (SCAQMD):

The SCAQMD is the local enforcement and notification agency within Orange, and populated portions of Los Angeles, San Bernardino and Riverside Counties in the State of California.

Surfactant:

A chemical wetting agent added to water to improve penetration.

Toxicity Characteristic Leaching Procedure (TCLP):

Laboratory test to be conducted on waste to determine if it meets the definition of hazardous waste.

Total Threshold Limit Concentration (TTLC):

Laboratory test to be conducted on waste to determine if it meets the definition of hazardous waste.

Visible Emissions:

Any emissions containing particulate material that is visually detectable without the aid of instruments. This does not include condensed uncombined water vapor.

Wet Cleaning:

The process of eliminating asbestos contamination from building surfaces and objects by using cloths, mops, or other cleaning utensils which have been dampened with water and afterwards thoroughly decontaminated or disposed of as lead contaminated waste.

1.05 SUBMITTALS AND NOTICES

A. No later than 10 days prior to commencement of work, Contractor shall submit in electronic format or PDF files to the Owner Representative and/or Consultant documentation that includes, without limitation, the following:

1. Current Copies of licenses and registrations required by Article 1.03, Qualifications (include copies of subcontractor's licenses).
2. Notify the Cal/DOSH at least 24 hours prior to commencement of any lead-related work, per the requirements of 8 CCR 1532.1.
3. Current proof of insurance coverage required by Article 1.10 Insurance Requirements (include proof of insurance for subcontractors).
4. Current proof that required permits, site location and arrangements for transport and disposal of asbestos materials have been made.
5. Current proof of legal right to use patented equipment or processes.
6. Current Manufacturer's certification that HEPA vacuums, differential pressure air filtration devices and other local exhaust ventilation equipment conform to ANSI Z9.2-79 and have been permitted by the SCAQMD.
7. Current documentation showing that Contractor's employees, including foreman, supervisor, and any other company personnel or agents who may be exposed to lead or who may be responsible for any aspects of lead abatement activities, have received training as required by 29 CFR 1926.1101 and 8 CCR 1529.
8. Current documentation from Physician (signed by an M.D.) showing that all employees or agents who may be exposed to lead dust in excess of background levels have received medical monitoring to determine whether they are physically capable of working while wearing the respirator required without suffering adverse health effects. The Contractor must be aware of and provide information to the examining physician about unusual conditions in the workplace environment (e.g. high temperatures, humidity, chemical contaminants) that may impact on the employee's ability to perform work activities.

Evidence of blood lead level testing of workers assigned to the project as well as medical clearance for the work to be performed and clearance to don respirators including fit testing records.

9. Current documentation of respirator fit-testing for all Contractor employees and agents who must enter the work area. This fit-testing shall be conducted annually and in accordance with procedures as required by 29 CFR 1910.134 and 8 CCR 5144.
10. An emergency preparedness plan as required by Article 1.07 - Emergency Planning.

11. Master schedule, showing phasing, number of shifts, time for air clearances, tear down and manpower loading to be utilized for the duration of the project.
 12. A site-specific work plan based on scope of work. Include a diagram showing containment set-up, decontamination unit(s), locations of negative air machines and exhaust placement.
 13. The name, address and telephone number of the transporter and disposal facility must be provided to the Owner.
- B. During abatement activities, Contractor shall submit to the Owner Representative and/or Consultant documentation that includes, without limitation, the following:
1. Copies of the work area entry/exit log book. Log book must record name, affiliation, time in, and time out for each entry into the work area.
 2. Copies of logs documenting filter changes on respirators, HEPA vacuums, differential pressure air filtration devices, water filtration device, and other engineering controls.
 3. Copies of Safety Data Sheets (SDS) for solvents, encapsulants, wetting agents, replacement materials, and other substances brought by Contractor to the Project Site. SDSs shall be available the first day that subject materials/substances are present on the project site.
 4. Results of all required Cal/DOSH compliance air monitoring. Results shall be available prior to the start of the following shift and within 24 hours of completion of the last shift.
 5. Copies of all accident/incident reports where injury or damage has occurred on or to the Owner's property.
 6. Copies of daily work logs indicating location(s) worked, type of materials removed, quantity of materials removed and number of personnel conducting the aforementioned activities.
 7. Contractor shall provide unit costs for the preparation of regulated work areas, abatement, waste storage and disposal for lead encountered during abatement and or renovation of the buildings located at the property. Rates for labor of appropriately trained workers, supervisors and management shall be included in the listing of unit rates.
 8. Copies of all transport manifests, trip tickets and disposal receipts for all lead waste materials removed from the work area shall be provided. Copies shall be emailed to the following individual(s):

Mr. Matt Fulton
Project Manager
San Bernardino City Unified School District
Facilities Planning & Management
956 West 9th Street
San Bernardino, CA 92411
Matt.fulton@sbcusd.k12.ca.us

9. A Close out Report will be generated by the Environmental Consultant at the conclusion of the abatement activities. Documents referenced in the section shall be provided to the Environmental Consultant for inclusion in the Close out Report.
- C. For any new lead abatement employee hired, who has not been previously reported, complete data must be submitted, consisting of: experience, certification, assigned job responsibilities, respirator test fitting, physicians determination of employee's ability to work while wearing respirator and evidence of medical monitoring (blood lead).

1.06 SITE SECURITY

- A. Contractor shall be responsible for the security of the regulated area(s) during abatement operations in order to protect work efforts and Owner equipment. Contractor will also be responsible for the security of all their equipment and materials on the job site.
- B. The regulated area shall be restricted to only authorized, trained, and protected personnel. These may include the Contractor's employees, employees of subcontractors, State representatives, and any other designated individuals. A list of authorized personnel shall be established prior to job start and posted in the clean room of the decontamination facility. A log book shall be maintained in the clean room area of the decontamination system. Anyone who enters the regulated area must record name, affiliation, time in, and time out for each entry.
- C. Contractor shall assure any unauthorized individual entering the regulated area is decontaminated (if required), evict them, and notify the Owner Representative of the actions taken and the identity of the unauthorized individual.
- D. Access to the regulated area shall be through a single decontamination system. All other means of access (doors, windows, hallways, etc.) shall be blocked or locked so as to prevent entry to or exit from the regulated area. The only exceptions to this rule are the waste pass-out air lock which shall be sealed except during the removal of containerized asbestos waste from the regulated area, and emergency exits in case of fire or accident. Emergency exits shall not be locked from the inside. However, they shall be sealed with polyethylene sheeting and tape until needed.

1.07 EMERGENCY PLANNING

- A. Emergency procedures shall be in written form and prominently posted in the clean change area and equipment room of the worker decontamination area. Everyone prior to entering the regulated area must read and sign these procedures to acknowledge receipt and understanding of work site layout, location of emergency exits and emergency procedures.
- B. Contractor employees shall be trained in evacuation procedures in the event of workplace emergencies under the following conditions:
 1. For non-life-threatening situations, employees injured or otherwise incapacitated shall decontaminate following normal procedures with assistance from fellow workers, if necessary, before exiting the workplace to obtain proper medical treatment.
 2. For life-threatening injury or illness, worker decontamination shall take least priority; after measures to stabilize the injured worker, remove the worker from the workplace and secure proper medical treatment.

- C. Telephone numbers of all emergency response personnel shall be prominently posted in the clean change area and equipment room along with the location of the nearest telephone.
- D. Exit routes should be clearly identified in the containment.
- E. Procedures to prevent and treat heat stress must be posted in the clean room area. Workers shall be provided easy access to drinking water outside of the regulated area(s) and encouraged to drink frequently.

1.08 MEETINGS

- A. Refer to Division 1.

1.09 DELIVERY, STORAGE, AND HANDLING

- A. Refer to Division 1.

1.10 INSURANCE REQUIREMENTS

- A. Refer to Division 1 and Owner and General Contractor insurance requirements.

1.11 BONDING REQUIREMENTS

- A. Refer to Division 1 and Owner and General Contractor Subcontractor Agreements.

1.12 PROJECT SCHEDULE

- A. Project Start Date: Refer to Owner or General Contractor's Instructions to Bidders and Published Project Schedule. Multiple notices to regulatory agencies and mobilizations will be required, as the project is phased.

PART 2 PRODUCTS

2.01 MATERIALS

- A. Polyethylene sheeting for all uses shall be a minimum of six (6) mil thickness. Widths will be selected to minimize the frequency of joints. All plastic, spray-on strippable coatings and structural materials shall be UL-certified as fire-retardant or non-combustible.
- B. Deliver all materials in the original packages, containers, or bundles bearing the name of the manufacturer and brand name (where applicable).
- C. Polyethylene sheeting utilized for decontamination enclosure shall be opaque white or black in color and 6-mil in thickness.

- D. Disposal bags shall be of six (6) mil polyethylene, clear bags.
- E. Metal disposal bins shall be used for the storage of asbestos-containing waste materials. Bins shall be lined in plastic sheeting affixed with spray glue and tape at walls, floor and ceiling of the bin. As an alternate, disposal drums for transporting disposal bags may be used. Drums shall be metal, 55-gallon DOT A1A (DOT 17H) with locking ring tops and will meet the requirements of 49 CFR 172 – 178. Stick-on labels as per EPA and 8 CCR 1529 (k) (8) requirements shall be provided for the disposal drums.
- B. Surfactant (Wetting Agent) for Amended Water:
 - 1. For wetting all materials containing lead, it shall consist of soapy water mixed in a proportion of two (2) fluid ounces of liquid sap to five (5) gallons of water.
 - 2. Where regulated area temperature may cause freezing of the amended water solution, the addition of ethylene glycol in amounts sufficient to prevent freezing is permitted.
- G. Encapsulating Material: Bridging type encapsulant (for sealing masonry and concrete walls, barrier surfaces during cleanup phase and lead containing surfaces to remain in place) shall be capable of being applied with airless spray equipment, able to withstand light impact or abrasion without releasing fibers, and be water insoluble when cured, and must retain sufficient integrity after six (6) years to allow recoating.
- G. Durable exterior coating over stabilized LBP: The coating to be used will be designated by Owner Representative.
- H. All caustics shall be properly labeled and containerized in lead-tight containers.

The following procedures and equipment may not be applicable to the lead abatement required for the particular project but are included for completeness. The removal/abatement of lead-containing ceramic tiles, as necessary, would comply with Section M below.

- J. Chemical Stripping Removers (**Alternative**) - Chemical removers shall contain no methylene chloride products. Chemical removers shall be compatible with and not harmful to the substrate to which they are applied. Chemical removers used on masonry surfaces shall contain anti-stain formulation that inhibits discoloration of stone, granite, brick and other masonry construction. Chemical removers used on interior surfaces shall not raise or discolor the surface being abated.
- K. Chemical Stripping Agent Neutralizer (**Alternative**) - Chemical stripping agent neutralizers may be used on exterior surfaces only. Neutralizers shall be compatible with and not harmful to the substrate that they are applied to. Neutralizers shall be compatible with the stripping agent that has been applied to the surface substrate.
- L. Paint Blasting Materials (**Alternative**) – Blasting materials shall not create respirable crystalline silica dust. The blasting debris will be considered hazardous waste for lead. The building must be encased/enclosed in a manner that does not allow visible dust from the building exterior during blasting.
- M. Component removal (**Alternative**) – Building Components coated with LBP (or lead containing glaze) can be removed from the regulated area, wrapped in 6-mil plastic sheeting, or placed in 6-mil plastic bags. Provision must be made with Owner Representative and Consultant for replacement of the component, as necessary.

2.02 EQUIPMENT

A. Negative Pressure Ventilation Units (Use as applicable):

1. A sufficient quantity of negative pressure ventilation units equipped with HEPA filtration and operated in accordance with ANSI and EPA guidance documents. They shall be utilized so as to provide one workplace air change every 15 minutes.

To calculate total air flow requirement:

$$\text{Total Ft}^3/\text{Min.} = \frac{\text{Volume of Regulated area (in Ft}^3\text{)}}{15 \text{ Min.}}$$

To calculate the number of units needed for the abatement:

$$\text{Number of Units Needed} = \frac{\text{Total Ft}^3/\text{Min.}}{0.75(\text{Capacity of Unit in Ft}^3/\text{Min.})}$$

2. The air filtering equipment shall be capable of filtering lead particles at 99.97 percent efficiency. Pre-filters, which protect the final filter by removing the larger particles, are required to prolong the operating life of the HEPA filter. Two stages of pre-filtration are required. The first-stage pre-filter shall be a low efficiency type (e.g., for particles 10 um and larger). The second-stage (or intermediate) filter shall have a medium efficiency (e.g., effective for particles down to 5 um). Pre-filters and intermediate filters shall be installed either on or in the intake grid of the unit and held in place with special housings or clamps.
 3. The exhaust air for the air filtering devices used to maintain negative pressure in the contained regulated area(s) shall be directed outdoors to an area where unprotected personnel are not present.
 4. The regulated area shall be maintained at a negative pressure of 0.02 inches of water (head). The ventilation shall operate on a 24-hour basis throughout the abatement process until final clearance has been approved.
- B. Air Purifying Respirators: Respirator bodies shall be of half face or full-face type with removable cartridges. Single use, disposable or quarter face respirators shall not be used. Full face respirators shall be equipped with a nose cup or other anti-fogging devices as would be appropriate for use in air temperatures less than 32 degrees F. Filter cartridges shall, at a minimum, be HEPA type filters certified by NIOSH under 30 CFR Part 11 or with filters certified for particulates under 42 CFR Part 84 (e.g., P100).
- C. Full body disposable protective clothing, including head, body and foot coverings consisting of material impenetrable by asbestos fibers (Tyvek® or equivalent) shall be provided to all workers and authorized visitors in sizes adequate to accommodate movement without tearing.
1. Full body disposable protective clothing as described above shall be provided to authorized visitors in sizes adequate to accommodate movement without tearing on request.
- D. Additional safety equipment (as necessary), such as hard hats, eye protection, safety shoes, disposable gloves meeting the requirements of current ANSI Standards shall be provided to all

workers and authorized visitors. Nonskid footwear shall be provided to all abatement workers. Disposable clothing shall be adequately sealed to the footwear and gloves to prevent body contamination.

- E. Provide sufficient supply of disposable mops, rags and sponges for work area decontamination. Rubber dust pans and rubber squeegees shall be provided for cleanup.
- F. Provide scaffolds, ladders, lifts and hand tools such as scrapers, wire cutters, brushes, utility knives, and wire saws, as the work requires. Brushes utilized for removing loose asbestos containing material shall have nylon or fiber bristles, not metal.
 - 1. Contractor must have in place a valid Fall Protection Plan, in compliance with Cal/DOSH requirements, to be reviewed and approved by the Owner Representative.
- G. Sprayers shall have pumps capable of providing 14-15 pounds per square inch (psi) at the nozzle tip at a flow rate of 2 gallons per minute for spraying amended water.
- H. A sufficient supply of HEPA filtered vacuum systems shall be available during cleanup.
- I. Airless spray equipment with an adjustable low-pressure nozzle shall be provided for spraying encapsulants. Nozzle tip size and pressure adjustment shall conform to encapsulant manufacturer's written recommendations.
- J. Machine Sanding Equipment - Sanders shall be of the dual action, rotary action, orbital or straight-line system type, fitted with a high efficiency particulate air (HEPA) dust pick-up system. Air compressors utilized to operate this equipment shall be designed to continuously provide 90 to 110 p.s.i. or as recommended by the manufacturer.
- K. Heat Blower Gun Equipment - Electrically operated, heat- blower gun shall be a flameless electrical paint softener type. Heat blower shall have electronically controlled temperature settings to allow usage below a temperature of 1,100 degrees Fahrenheit. Heat blower shall be DI type (non-grounded) 120 V, AC application. Heat blower shall be equipped with various nozzles to cover all common applications (cone, fan, glass protector, spoon reflector, etc.).
- L. Heavy duty power cables for temporary electrical service and a portable electric generator for maintaining negative pressure in the work area in case of power failure.
- M. Warning Signs and Labels: As required OSHA Regulation 29 CFR 1926.629(m) and 8 CCR 1532.1.
- N. Other equipment the Contractor deems necessary for lead work shall be submitted to the Owner Representative and/or Consultant for approval prior to their use.

PART 3 EXECUTION

3.01 GENERAL COMPLIANCE MEASURES

- A. Mandatory Protection Conditions: Contractor's employees shall wear appropriate respiratory protection and protective clothing under the following conditions:
1. During installation or implementation of engineering work practices and control measures.
 2. During maintenance and repair activities for which control measures, hereinafter described, are not feasible.
 3. Whenever the control measures are not yet sufficient to reduce exposure below the Permissible Exposure Limits (TWA and/or Excursion Limits).
 4. Whenever emergency conditions exist.
- B. Control Measures: The Contractor shall use one or any combination of the following control methods to achieve compliance with the "Permissible Exposure Limits" defined herein:
1. Local exhaust ventilation equipped with HEPA filter dust collection systems (ref. 2.02).
 2. General dilution ventilation equipped with HEPA filtration systems on both exhaust and return air (ref. 2.02).
 3. Vacuum cleaners equipped with HEPA filters (ref. 2.02).
 4. Enclosure or isolation of processes producing airborne lead dust.
 5. Use of wet methods, wetting agents or removal encapsulants to control employee exposures during their performance of asbestos abatement activities.
 6. Prompt clean up and disposal of wastes contaminated with lead in leak-tight containers.
- C. Supplement to Control Measures: Whenever the control measures described above are not sufficient to reduce the employee exposure to or below the "Permissible Exposure Limits" (TWA and/or Excursion Limit), the Contractor shall continue to use the control measures to maintain the employee exposure to the lowest levels attainable and supplement them with the use of appropriate respiratory protection and protective clothing.
- C. Negative-Pressure Enclosure: A negative-pressure enclosure shall be employed whenever feasible, prior to commencing removal, demolition and renovation operations involving lead containing materials. The negative air machines (ref. 2.02) should be ducted outdoors, especially if the space outside the containment is occupied. This will prevent the indoor spread of contamination if the negative air machine malfunctions or other chemicals are used in the containment (not recommended) which would not be filtered by the machines. If the area of work outside is dusty, then a square hole may be cut in the containment and fitted with a pleated residential air filter (Minimum Efficiency Reporting Value [MERV] 11 or better) to filter the make-up air. The entry to the containment should be well sealed to prevent the entry of unfiltered outside air.

- E. Types of Respiratory Protection: The following Table represents the minimum respiratory protection required for given airborne concentrations of lead:

Airborne Concentration of Lead milligrams per cubic meter (mg/M ³)	Required Respirator
Not in excess of 0.50 mg/M ³ (10x PEL)	Half-mask air purifying respirator equipped with high-efficiency filters.
Not in excess of 2.50 mg/M ³ (50x PEL)	Full faceplate air purifying respirator equipped with high-efficiency filters.
Not in excess of 5.00 mg/M ³ (100x PEL)	1. Any powered air purifying respirator equipped with high efficiency filters. 2. Any supplied air respirator operated in continuous flow mode.
Not in excess of 50.0 mg/M ³ (1000x PEL)	Full face piece supplied air respirator operated in pressure demand mode.
Greater than 50.0 mg/M ³ (1,000x PEL) or unknown concentration	Full face piece supplied air respirator operated in pressure demand mode equipped with an auxiliary positive pressure self-contained breathing apparatus.

NOTE: Respirators assigned for higher environmental concentrations may be used at lower concentrations. A high-efficiency filter means a filter that is at least 99.97 percent efficient against mono-dispersed particles of 0.3 micrometers in diameter or larger.

- D. Respirator use during initial air monitoring must be selected per the requirements outlined in 29 CFR 1926.62(d)(2) or State equivalent.

3.02 LBP/LEAD-CONTAINING MATERIALS AND SURFACE COATING IMPACTS

This section applies to the removal of LBPs or lead-containing paints and/or the demolition of components coated with lead coatings.

- A. Post warning signs meeting the specifications of 8 CCR 1532.1 and 29 CFR 1926.62 at any location and approaches to a location where airborne concentrations of lead dust may exceed ambient background levels. Signs shall be posted at a distance sufficiently far enough away from a work area to permit a person to read the sign and take necessary protective measures to avoid exposure. Barrier tape shall be utilized in conjunction with signs for exterior removal activities, to delineate the extent of regulated work areas.
- B. Prepare appropriate fall protection systems in accordance with the requirements of Title 8 California Code of Regulations, Sections 1669, 1670, 1724 and anchoring guidance from Title 8 California Code of Regulations, Section 3283 (where applicable).
- C. Install worker decontamination unit described in Article 3.04 or as agreed upon with Project Environmental Consultant.
- D. Lead-containing material handlers involved in removal procedures shall wear disposable Tyvek suits, including gloves, hood, and footwear. Minimum respiratory protective equipment shall be half-face air-purifying respirators equipped with P100 filters.
- For exterior lead work, it is recommended that workers wear two (2) disposable Tyvek suits. Upon exiting the work area, the handlers shall HEPA vacuum all visible debris from

the outer suit, dispose of it as lead-contaminated waste, and proceed through the decontamination unit for full decontamination.

- E. Isolate work area by installing critical barriers or curtained doorways across all openings where airborne lead dust migration may cause secondary lead contamination (for work where components will be removed relatively intact, such as doors, downspouts, and wood trim, drop cloths will suffice). Establish regulated areas with delineators, barrier tape and lead signage for exterior work areas.
- F. Cover floors in each work area with fire retardant polyethylene sheeting (do not cover floors where flooring finishes, such as ceramic flooring, for example, are to be removed).
 - 1. A single layer of six-mil (minimum) sheeting.
 - 2. Containment plastic shall be sized to minimize seams.
 - 3. Where multiple layers of floor poly are utilized, sheeting shall be installed in a fashion so as to prevent slippage between successive layers of material.
- G. Cover all immovable items and/or construct walls in the Work Area with fire retardant polyethylene sheeting. Walls that will be demolished do not necessarily need protection (check with Project Environmental Consultant).
 - 1. Walls shall be covered with six-mil fire-retardant polyethylene sheeting (sealed airtight with duct tape).
 - 2. Plastic shall be sized to minimize seams.
 - 3. Wall sheeting shall overlap floor sheeting by at least 12 inches beyond the wall/floor joint to provide a better seal for negative pressure.
 - 4. Wall sheeting shall be secured adequately to prevent it from falling away from the walls. This may require additional support/attachment when Negative Pressure Ventilation Systems area utilized.
 - 5. Fire exits shall be clearly labeled with red tape or equivalent.
- H. Where manual demolition is employed for lead removal, such as ceramic tile demolition (for example), periodically mist the work area and materials to be impacted to maintain a wet condition and avoid the creation of airborne dust, which may carry lead.
- I. The Contractor shall carry out all impacts to lead-based surface coatings in a manner that will minimize pulverizing, breaking, abrading, or in any other way impacting lead-containing paints and generating airborne lead-containing dust.
- J. Once all removal activities have been completed, clean-up of the work areas shall be conducted in accordance with Article 3.12 - Clean-Up.
- K. Dispose of all lead-containing/contaminated waste in accordance with Article 3.14 - Disposal Procedures.

3.03 Surface Preparation - LBP Stabilization

Contractor shall be responsible to conduct stabilization as necessary and limit the amount of lead-containing dust generated. Damaged paint (loose, flaking or peeling, etc.) shall be stabilized in accordance with the following:

- A. Post warning signs meeting the specifications of 8 CCR 1532.1 and 29 CFR 1926.62 at any location and approaches to a location where airborne concentrations of lead dust may exceed ambient background levels. Signs shall be posted at a distance sufficiently far enough away from a work area to permit a person to read the sign and take necessary protective measures to avoid exposure. Barrier tape shall be utilized in conjunction with signs for exterior removal activities, to delineate the extent of regulated work areas.
- B. Prepare appropriate fall protection systems in accordance with the requirements of Title 8 California Code of Regulations, Sections 1669, 1670, 1724 and anchoring guidance from Title 8 California Code of Regulations, Section 3283 (where applicable).
- C. Install worker decontamination unit described in Article 3.4 or as agreed upon with Environmental Consultant.
- D. Abatement workers involved in stabilization procedures shall wear two disposable Tyvek suits, including gloves, hood and footwear. Minimum respiratory protective equipment shall be half-face air-purifying respirators equipped with P100 filters. Upon exiting the work area the handlers shall HEPA vacuum all visible debris from the outer suit, dispose of it as lead-contaminated waste, and proceed through the decontamination unit for full decontamination.
- E. Isolate work area by installing critical barriers where airborne lead dust migration may cause secondary lead contamination (for work where components will be removed relatively intact, such as doors, downspouts, and wood trim, drop cloths will suffice). At a minimum, the work area will be delineated with the use of appropriately labeled barrier tape and signs. Plastic sheeting shall be placed out a minimum of five (5) feet from the component to be removed.
- F. Cover adjacent areas, if appropriate, to each work area with fire retardant polyethylene sheeting.
 1. A single layer of six-mil (minimum) sheeting.
 2. Containment plastic shall be sized to minimize seams.
 3. Where multiple layers of floor poly are utilized, sheeting shall be installed in a fashion so as to prevent slippage between successive layers of material.
- G. Cover all immovable items and/or construct walls in the Work Area with fire retardant polyethylene sheeting. Walls that will be impacted do not necessarily need protection (check with Project Environmental Consultant).
 1. Walls shall be covered with six-mil fire-retardant polyethylene sheeting (sealed airtight with duct tape).
 2. Plastic shall be sized to minimize seams.
 3. Wall sheeting shall overlap floor sheeting by at least 12 inches beyond the wall/floor joint to provide a better seal for negative pressure.
 4. Wall sheeting shall be secured adequately to prevent it from falling away from the walls. This may require additional support/attachment when Negative Pressure Ventilation Systems area utilized.
 5. Fire exits shall be clearly labeled with red tape or equivalent.

- H. Prior to stabilization of LBP, correct substrate surfaces of defects as necessary.
- I. Paint stabilization activities must utilize wet scraping methods. HEPA vacuums shall be used to clean up small debris generated during lead paint stabilization activities. Do not allow dust and debris to accumulate.
- J. Where manual demolition is employed for lead removal, periodically mist the work area and materials to be impacted to maintain a wet condition and avoid the creation of airborne dust, which may carry lead.
- K. The Contractor shall carry out all impacts to lead-based surface coatings in a manner that will minimize pulverizing, breaking, abrading, or in any other way impacting lead-containing paints and generating airborne lead-containing dust.
- L. Once all removal activities have been completed, clean-up of the work areas shall be conducted in accordance with Article 3.12, Clean-Up Procedures.
- M. Dispose of all lead-containing/contaminated waste in accordance with Article 3.14, Disposal Procedures.

3.04 DECONTAMINATION ENCLOSURE SYSTEM

- A. Worker decontamination enclosure systems shall be provided at all locations where workers will enter or exit the work area. At a minimum, one, three-stage system at a single location is preferred. Each work area where negative pressure enclosure is the selected method of engineering controls shall have a worker decontamination unit.

In the event that a three-stage decontamination unit includes a shower, the shower must be connected to a water source and have a water filtration unit attached and functioning. As an alternate, a cleansing station may be used. See Item E below.
- B. Worker decontamination enclosure systems constructed at the Project site shall utilize six-mil, fire-retardant polyethylene sheeting, or other approved materials for privacy.
- C. Personnel Decontamination Units shall not be located inside the work area(s) unless specifically authorized by the Environmental Consultant.
- D. Alternate methods of providing Decontamination facilities may be submitted to the Environmental Consultant for approval. Do not proceed with any such method(s) without the written authorization from Owner Representative and/or Consultant.
- E. The worker decontamination enclosure system shall consist of at least a cleansing station in accordance with the requirements of 8 CCR 1527 and 8 CCR 1529, equipped with adequate water, towels and cleansing agents to accommodate the entire crew and visitors.
- F. All polyethylene barriers and decontamination enclosure systems shall be inspected at least twice daily by the Contractor's competent person prior to the start of each day's abatement activities and following the completion of the day's abatement activities.
- G. Damage and defects in the enclosure system are to be repaired immediately upon discovery.

3.05 WORKPLACE ENTRY AND EXIT PROCEDURES

- A. All workers and authorized personnel shall enter the regulated area through the decontamination enclosure system.
- B. All personnel shall proceed first to the clean room, remove all street clothes, and appropriately don respiratory protection (as approved for the job conditions) and disposable coveralls, head covering and foot covering. Hard hats, eye protection and gloves shall also be utilized, if required. Clean respirators and protective clothing shall be provided and utilized by each person for each separate entry into the regulated area.
- C. Personnel wearing designated personal protective equipment shall proceed from the clean room through the decontamination enclosure system to the regulated area.
- D. Before leaving the regulated area, all personnel shall remove gross contamination from the outside of respirators and protective clothing by brushing or wet wiping procedures. Small HEPA vacuums with brush attachments may be utilized for this purpose. Each person shall clean bottoms of protective footwear in the walk-off pan just prior to entering the equipment room/pre-shower chamber.
- E. Personnel shall proceed to equipment room where they remove all protective equipment except respirators. Deposit disposable clothing into appropriately labeled containers for disposal.
- F. Reusable, contaminated footwear shall be stored in the equipment room when not in use in the regulated area. Upon completion of abatement, it shall be disposed of as asbestos contaminated waste. Rubber boots may be decontaminated at the completion of the abatement for reuse.
- G. Workers will decontaminate all respirators and non-porous items with wet towels, rags provided in the equipment room. Workers will remove filter cartridges and dispose of them in the bag or receptacle provided in the equipment room. Workers will also wet wipe and decontaminate themselves in this location. Contaminated towels and suits shall be placed in bags/receptacles before proceeding to the clean room.
- H. Workers shall not eat, drink, smoke, and chew gum or tobacco in the regulated area. To eat, drink or smoke, workers shall follow the procedure described above, and then dress in street clothes before entering the non-regulated areas of the building.
- I. Emergency exits shall be established and clearly marked with duct tape arrows or other effective designations to permit easy location from anywhere within the regulated area. They shall be secured to prevent access from uncontaminated areas, but still permit emergency exiting. These exits shall be properly sealed with polyethylene sheeting which can be cut to permit egress, if needed. These exits may be through the decontamination enclosure, the waste pass-out airlock, and/or other alternative exits that are satisfactory to fire officials.

3.06 WASTE CONTAINER PASS-OUT PROCEDURE

- A. Lead contaminated waste that has been containerized shall be transported out of the regulated area through the waste container pass-out airlock (or through the decontamination enclosure if a separate airlock has not been constructed). Wherever possible, this shall be located where there is direct access from the regulated area to the outside of the building and the waste storage/disposal container. The waste container pass-out airlock shall be constructed in similar fashion to the worker decontamination enclosure system using similar materials and airlock and

curtain doorway designs. This airlock system shall not be used to enter or exit the regulated area. The airlock system shall be tightly sealed when not in use.

- B. The inside team wearing protective clothing and respirators appropriate for the contaminated regulated area shall clean the entire surface, including bottoms, of properly labeled bags, using HEPA vacuums and wet wiping techniques and transport them into the waste container pass-out airlock where they will be placed into another properly labeled bag. No worker from the inside team shall further exit the regulated area through this airlock.
- C. Workers from outside the regulated area wearing appropriately assigned respirators shall enter the airlock from outside the regulated area solely for waste removal from the work area. No worker from the outside team shall further enter the regulated area through this airlock.
- D. The exit from this airlock shall be secured to prevent unauthorized entry when not in use.

3.07 WATER COLLECTION AND DISPOSAL

- A. All water resulting from the pre-cleaning operation, excess from the floor of regulated area, decontamination water, and the final cleaning operation shall be collected and placed in a sealed container(s) for disposal as hazardous waste or for waste characterization to determine if it is hazardous waste. No water shall be disposed of in sanitary sewers or storm drains.

3.08 WET REMOVAL PROCEDURE

- A. Wet all lead containing material with an amended water solution using equipment capable of providing a fine spray mist, in order to reduce airborne fiber concentrations when the material is disturbed. Saturate the material to the substrate. Keep all removed material wet to prevent dust release until it can be containerized for disposal.
- B. Saturated lead waste shall be removed in manageable sections, but as large as practical. Removed material should be containerized before moving to a new location for continuance of work. Surrounding areas shall be periodically sprayed and maintained in a wet condition until visible material is cleaned up.
- C. Bags shall be considered full when half their capacity has been filled. They should be securely sealed to prevent accidental opening and leakage by tying tops of bags in an overhand knot or by taping in gooseneck fashion. Do not seal bags with wire or cord.
- D. Large components removed intact may be wrapped in two (2) layers of six (6) mil polyethylene sheeting secured with tape for transport to the approved disposal site.
- E. Lead containing waste with sharp edged components (e.g., nails, screws, metal lathe, tin sheeting) shall be placed into drums for disposal in lieu of polyethylene bags. Drums shall be marked to differentiate contents from those drums containing bagged material.
- F. After completion of all stripping work, surfaces from which lead has been removed such as plaster base coat or metal deck, etc., the surfaces shall be wet brushed and sponged to remove all visible residues.

3.09 ENCAPSULATION/STABILIZATION PROCEDURES

- A. Clean and isolate the regulated area as specified in Subpart entitled "3.02 LBP/Lead-Containing Surface Coating Impacts", hereinbefore.
- B. Repair damaged and missing areas of existing materials with non-lead-containing substitutes. Material must adhere adequately to existing surfaces and provide an adequate base for application of encapsulating agents. Filler material shall be applied in accordance with manufacturer's recommended specifications.
- C. Feather back rough edges of paint by carefully sanding with HEPA equipped sanders.
- D. Spray apply with airless equipment with low nozzle pressure to all surfaces where lead is removed or surfaces containing lead that are to remain in place. Spray must completely encapsulate any remaining lead, permanently locking it in place.
- E. Apply a minimum of one (1) coat with coverage in strict accordance with manufacturer's recommendations. Surfaces must be dry and free of dirt, oil and dust.

3.10 AIR MONITORING

- A. The Consultant (Owner's Representative) shall perform the ambient air sampling. All sample collection procedures and evaluation to determine employee exposure levels (Contractor responsibility) shall conform to the requirements of OSHA Standard 29 CFR 1926.62 or 8 CCR 1532.1. For exterior lead abatement areas, a minimum of two upwind and two downwind ambient air samples (one at each of four sides of the area is acceptable) shall be collected during the disturbance of lead containing materials (e.g., stabilization and coating). For interior lead abatement areas air samples shall be collected outside the perimeter of the regulated area(s), outside the decontamination unit, and outside the waste load-out unit. The samples shall be placed as close as practical to the affected area.
- B. All samples collected shall be analyzed on a 24-hour turnaround basis by a laboratory accredited by the California Environmental Laboratory Accreditation Program (CA ELAP) and the American Industrial Hygiene Association Laboratory Accreditation Programs, LLC (AIHA-LAP) under their Environmental Lead Laboratory Accreditation Program (ELLAP). The results of each analysis shall be submitted to the Owner's Representative within two hours of receipt from the lab. Copies of the analysis results shall also be made available to Owner Representative and the Contractor upon request and posted in the clean room or break area on the day of receipt from the lab.
- C. Documentation requirements must include the following, as a minimum:

Air Sampling Procedures: Sampling times, sampling locations (with appropriate diagrams), evidence of periodic inspection of sampling equipment, documentation of pre and post calibration of equipment, detailed description of work conditions, description of worker protective devices, and a description of any atypical environmental conditions.
- D. Minimum testing required for the project shall consist of the following:
 - 1. Exterior Testing During Exterior Paint Disturbance: Area air samples will be collected at the perimeters of the regulated area.

2. Personal Sampling for OSHA - PEL and Action Level - As required by 29CFR 1926.62 samples shall be within the breathing zone of each worker category (i.e., wetter, receiver, bagger, etc.) 25% of the crew, or one per job category (Contractor responsibility).

E. Daily Personal Air Monitoring (OSHA Compliance):

1. Daily determination of employee exposure during LBP disturbance (e.g., exterior paint stabilization and coating disturbance) shall be made by collecting one or more breathing zone samples that are representative of the 8-hour TWA, full-shift exposure for each employee in each regulated area.
2. Daily testing may be dispensed with if employees are equipped with supplied-air respirators operated in a positive-pressure mode while performing abatement work or sampling indicates that exposures do not exceed the OSHA Action Level.
3. Daily testing may also be dispensed with if the contractor is in possession of a negative exposure assessment performed in accordance with 8 CCR 1532.1 on the same workers for like tasks within the last 12 months.

3.11 WORK STOPPAGE

- A. The Owner's Representative has the authority to stop the abatement work under the provisions of the General Conditions of this contract at any time he/she determines either personally or through the services of the air sampling professional that conditions are not in compliance with the specifications and applicable regulations. The stoppage of work shall continue until conditions have been corrected and corrective steps have been taken to the satisfaction of the Owner's Representative. Standby time required to resolve violations shall be at the Contractor's expense.
- B. When exterior paint is being stabilized or removed any visible debris or dust must not migrate beyond the work area. If wind conditions cause this to occur, then work shall stop until the wind decreases to allow for no further dust/debris migration. Wind speed of over 10 mph may cause this. As such wind conditions expected for the days of work must be considered when planning these activities.

3.12 CLEANUP PROCEDURE

- A. Remove and containerize all visible accumulations of lead and lead contaminated debris utilizing rubber dust pans and rubber squeegees to move material around. Do not use metal shovels to pick up or move accumulated waste. Special care shall be taken to minimize damage to floor containment sheeting, when present.
- B. Wet clean all surfaces in the regulated area using rags, mops and sponges as appropriate. (Note: Some HEPA vacuums might not be wet-dry vacuums.)
- C. Prior to removing the inner layer of plastic sheeting, the sheeting shall be sprayed with an encapsulant so that any residue remaining will be adhered to the plastic sheeting.
- D. Remove the cleaned inner layer of plastic sheeting from walls and floors. Windows, doors, HVAC system vents and all other openings shall remain sealed. The negative pressure ventilation units shall remain in continuous operation. Decontamination enclosure systems shall remain in place and be utilized.

- E. Remove all containerized waste from the regulated area and waste container pass-out airlock. Decontaminate all tools and equipment and remove at the appropriate time in the cleaning sequence.
- F. The Owner's Representative and the Contractor shall inspect the regulated area for visible residue. If any accumulation of residue is observed, it will be assumed to be asbestos and the cleaning cycle shall be repeated.

3.13 CLEARANCE TESTING

- A. If requested by Owner Representative only. Either or both interior floor surfaces and exterior soils will be sampled. Clearance soil sampling will be conducted by the Consultant (Owner's Representative) of one area on each side of the building (four samples). Floor wipe samples will be collected from each affected interior space, as necessary.
- B. Submit samples to an CA ELAP certified laboratory for analysis.
- C. Interpret results by comparing them to the EPA Clearance Standards (40CFR 745.227(e)) or 17 CCR Division 1, Chapter 8 lead hazard standards. The standard for soil is ≤ 400 parts per million (ppm) (total lead). However, the soil testing before this project indicated no detectable lead above 130 ppm. This criteria will be met unless circumstances require alternative criteria.
- D. The floor wipe sampling clearance criteria is 10 microgram per square foot (per July 9, 2019 amendment to 745.65; Lead-based paint hazards which reads "(b) Dust-lead hazard. A dust-lead hazard is surface dust in a residential dwelling or child-occupied facility that contains a mass-per-area concentration of lead equal to or exceeding 10 $\mu\text{g}/\text{ft}^2$ on floors or 100 $\mu\text{g}/\text{ft}^2$ on interior windowsills based on wipe samples.")
- D. Should laboratory results indicate that either the soil or floor wipe clearance level is exceeded, the Contractor shall remove additional soil or reclean the affected areas, at no additional cost to the Owner, utilizing the methods specified above. Retesting will then be performed to verify compliance with the mandated levels. The Owner will pay for the initial clearance testing and one re-testing. The cost of any further retesting, necessitated as a result of failure to meet requirements for clearance, shall be borne by the Contractor.

3.14 DISPOSAL PROCEDURES

- A. Contractor is responsible for characterization of lead waste prior to waste being transported off site. All waste characterization samples must be taken under the supervision of the Project Environmental Consultant. Characterization sample results must be submitted to the Owner and/or Project Environmental Consultant for review prior to waste being transported off site.
- B. All lead wastes shall be either disposed of as construction debris (if STLC/TCLP results allow) or lead-containing waste (with attendant RCRA codes, if STLC/TCLP results so require).
- C. All hazardous wastes must be disposed of by a certified waste hauler approved by the Owner.
- D. Obtain the EPA Hazardous Waste Generator Identification Number and State of California Hazardous Waste Tax Identification Number from the Owner.

- E. All hazardous waste manifests, non-hazardous material data forms and bills of lading shall be delivered to the Project Environmental Consultant. Record keeping format shall utilize a chain of custody form which includes the names and addresses of the Generator (Owner), Contractor, Waste Hauler, pickup site, disposal site, the estimated quantity of the asbestos waste and the type of containers used. The form shall be signed by the Generator, Contractor, Waste Hauler and the Disposal Site Operator, as the responsibility for the material changes hands.

3.15 ALTERNATIVE PROCEDURES

- A. If specified procedures cannot be utilized, a request shall be made in writing to the Owner Representative and Consultant providing details of the problem encountered and recommended alternatives.
- B. Alternative procedures shall provide equivalent or greater protection than procedures that are replaced.
- C. Any alternative procedure must be approved in writing by the Environmental Consultant and the Owner Representative prior to the implementation of the procedure.

END OF SECTION

Attachment 2 – Request for Substitution at Time of Bid

Request for Substitution: NO YES

Pursuant to Public Contract Code section 3400, bidder submits the following request to Substitute with the bid that is submitted. I understand that if the request to substitute is not an “or equal” or is not accepted by DISTRICT and I answer “no” I will not provide the specified item, then I will be held non-responsive and my bid will be rejected. With this understanding, I hereby request Substitution of the following articles, devices, equipment, products, materials, fixtures, patented processes, forms, methods, or types of construction:

	Specification Section	Specified Item	Requested Substituted Item	Contractor Agrees to Provide Specified Item if request to Substitute is Denied ¹ (circle one)	DISTRICT Decision (circle one)
1.	075420	Sarnafil	Carlisle	Yes <input type="checkbox"/> No <input checked="" type="checkbox"/>	Grant Deny
2.				Yes No	Grant Deny
3.				Yes No	Grant Deny
4.				Yes No	Grant Deny
5.				Yes No	Grant Deny
6.				Yes No	Grant Deny
7.				Yes No	Grant Deny
8.				Yes No	Grant Deny
9.				Yes No	Grant Deny
10.				Yes No	Grant Deny
11.				Yes No	Grant Deny
12.				Yes No	Grant Deny

This Request Form must be accompanied by evidence as to whether the proposed Substitution (1) is equal in quality, service, and ability to the Specified Item; (2) will entail no change in detail, construction, and scheduling of related work; (3) will be acceptable in consideration of the required design and artistic effect; (4) will provide no cost disadvantage to the DISTRICT; (5) will require no excessive or more

¹ Bidder must state whether bidder will provide the Specified Item in the event the Substitution request is evaluate and denied. If bidder states that bidder will not provide the Specified Item the denial of a request to Substitute shall result in the rejection of the bidder as non-responsive. However, if bidder states that bidder will provide the Specified Item in the event that bidder’s request for Substitution is denied, bidder shall execute the Agreement and provide the Specified Item(s). If bidder refuses to execute the Agreement due to the DISTRICT’s decision to require the Specified Item(s) at no additional cost, bidder’s Bid Bond shall be forfeited.

expensive maintenance, including adequacy and availability of replacement parts; (6) will require no change of the construction schedule or milestones for the Project; and, (7) CONTRACTOR agrees to pay for any DSA Fees or other Governmental Plan check costs associated with this Substitution Request. (See General Conditions Section 3.6)

The undersigned states that the following paragraphs are correct:

1. The proposed Substitution does not affect the dimensions shown on the Drawings.
2. The undersigned will pay for changes to the building design, including Architect, engineering, or other consultant design, detailing, DSA plan check or other governmental plan check costs, and construction costs caused by the requested substitution.
3. The proposed substitution will have no adverse effect on other trades, the Contract Time, or specified warranty requirements.
4. Maintenance and service parts will be available locally for the proposed substitution.
5. In order for the Architect to properly review the substitution request, within five (5) days following the opening of bids, the CONTRACTOR shall provide samples, test criteria, manufacturer information, and any other documents requested by Architect or Architect's engineers or consultants, including the submissions that would ordinarily be required under Article 3.7 for Shop Drawings along with a document which provides a side by side comparison of key characteristics and performance criteria (often known as a CSI side by side comparison chart).
6. If Substitution Request is accepted by the DISTRICT, CONTRACTOR is still required to provide a Submittal for the substituted item pursuant to Article 3.7 and shall provide required Schedule information (including schedule fragments, if applicable) for the substituted item as required under Article 8.3.2.1. The approval of the Architect, Engineer, or DISTRICT of the substitution request does not mean that the CONTRACTOR is relieved of CONTRACTOR's responsibilities for Submittals, Shop Drawings, and schedules under Article 3.7 and 8.3.2 if the CONTRACTOR is awarded the Project.

Name of Bidder: Kiss Enterprises dba. Golden State Roofing

By: Peter Simon

DISTRICT: _____

By: _____



◀ PVC Roofing Substitution Request

San Bernardino City Unified School District
Building M Maker Space

Golden State Roofing

System Overview

Product Reviews

*Product Data
Sheets*

*Testing and
Warranty*

Documents



Arturo Ortiz
Specified Sales, Inc.
818-813-4082

arturo@specifiedsales.com



June 15, 2021

GOLDEN STATE ROOFING

22120 AVALON BLVD

CARSON, CA 90745

US

Project: San Bernardino HS Bldg M - Maker Space

To Whom It May Concern:

This letter is to confirm that GOLDEN STATE ROOFING in CARSON, CA is a Carlisle Authorized Applicator.

This Applicator has been awarded with the following awards:

ESP 2021

If you should have any further questions, please feel free to contact me.

Sincerely,

A handwritten signature in black ink, appearing to read "Ryan Paxton". The signature is fluid and cursive, with a large initial "R" and a long, sweeping tail.

Ryan Paxton

Regional Sales Manager, North West

/ems

CSI Form 1.5C

SUBSTITUTION REQUEST (During the Bid Period)

Project: San Bernardino City Unified SD Building "M" Makers Space
To: To Whom it May Concern
Re:
Substitution Request Number: From: Carlisle Syntec
Date: 6-15-2021
A/E Project Number:
Contract For:

Specification Title: Adhered Feltback PVC Thermoplastic Membrane Roofing Description: Feltback fiberglass reinforced membrane
Section: 075420 Page: Article/Parag 2.2

Proposed Substitution: Carlisle PVC 115 and 135 -Mil Fully Adhered Feltback Roofing System (60 & 80 Mil)
Manufacturer: Carlisle Syntec
Trade Name: Sure-Flex

Attached data includes product description, specifications, drawings, photographs, and performance and test data adequate for evaluation of the request; applicable portions of the data are clearly identified.
Attached data also includes a description of changes to the Contract Documents that the proposed substitution will require for its proper installation.

- The Undersigned certifies:
Proposed substitution has been fully investigated and determined to be equal or superior in all respects to specified product.
Same warranty will be furnished for proposed substitution as for specified product.
Same maintenance service and source of replacement parts, as applicable, is available.
Proposed substitution will have no adverse effect on other trades and will not affect or delay progress schedule.
Proposed substitution does not affect dimensions and functional clearances.

Submitted by: Karen Smith
Signed by: Karen Smith
Firm: Carlisle Syntec
Address: 1285 Ritner Hwy
Carlisle PA 17013
Telephone: 253-271-3221

A/E's REVIEW AND ACTION
Substitution approved - Make submittals in accordance with Specification Section 01 25 00 Substitution Procedures.
Substitution approved as noted - Make submittals in accordance with Specification Section 01 25 00 Substitution Procedures.
Substitution rejected - Use specified materials.
Substitution Request received too late - Use specified materials.

Signed by: Date:

Supporting Data Attached: Drawings Product Data Samples Tests Reports

FleeceBACK® PVC

Adhered System

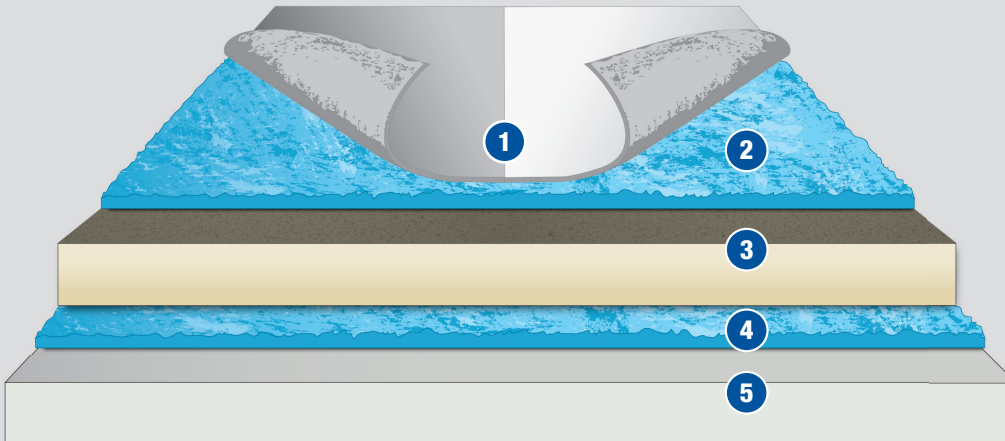

- 1 FleeceBACK PVC Polyester Reinforced Membrane
- 2 Flexible FAST™ Adhesive
- 3 Approved Carlisle Insulation
- 4 Flexible FAST Adhesive
- 5 Approved Roof Deck

72 and 60 Mils thick
min.

FleeceBACK PVC Membranes for adhered roofing systems are available in the following:

Thicknesses	Roll Size	Color
115-mil	10' x 100'	White, Gray, Tan, Light Gray, and Slate Gray
135-mil	10' x 75'	White, Gray, Tan, Light Gray, and Slate Gray

Description

Carlisle's FleeceBACK PVC polyester reinforced membrane is tough, durable, and versatile, making it ideal for a wide variety of re-roofing and new construction projects.

FleeceBACK PVC polyester reinforced membrane offers exceptional weatherability, flexibility, and toughness due to its polyester reinforcing scrim and polyester fleece backing. The polyester reinforcing scrim provides the sheet with added breaking strength, tear strength and puncture resistance for fully adhered or mechanically attached applications; the fleece backing adds to the puncture-resistance of the membrane and provides a built-in separation layer against rough concrete decks or existing asphaltic-based roofing systems. Years of proven PVC formulation performance helps to ensure the membrane remains pliable and weldable as it ages.

System Features & Benefits:

- » Added Puncture / Tear Resistance
 - Polyester scrim and external Fleece provide excellent puncture resistance
 - Fleece backing provides 30% greater puncture resistance than standard membrane
 - Combination of FleeceBACK PVC membrane with Flexible FAST adhesive increases puncture resistance up to 50% compared to traditional competitive low-rise adhesives
- » Superior Wind Uplift
 - Uplift pressures ranging from 90–945 psf depending on the substrate. Due to its superior wind uplift performance, the FleeceBACK/Flexible FAST Adhesive System can qualify for upgraded wind speed warranties of 80–120 mph with design enhancements
- » Increased Hail Performance
 - Passes FM's severe hail test
 - Passes UL-2218 Class 4 rating

FleeceBACK® PVC Adhered System

- » Expedient Installation without Interruptions
 - Due to the low noise and low odor associated with the system, the FleeceBACK/Flexible FAST assembly is an excellent choice for re-roofing occupied buildings, as there is minimal disruption
 - Labor-savings 10'-wide sheets result in 67% fewer seams than a modified bitumen system of comparable size
- » Energy Efficient and Environmentally Sounds
 - Each layer of full coverage Flexible FAST provides an additional R-Value of .20-.50 per layer
 - Insulation adhered with Flexible FAST can reduce R-value loss by 3-8% by expanding and sealing insulation joints
- » Longer Term Performance
 - Enhanced physical property characterizes for long-term weatherability
 - Excellent chemical resistance to acids, bases, restaurant oils, and grease
 - Meets ENERGY STAR®, CRRC, LEED, and Title 24 guidelines (white only)

Existing or New Deck Type	New Construction						Re-roofing		
	Steel	Plywood or OSB	Lt. Wt. Concrete	Structural Concrete	Wood Planks	Gypsum & Fibrous Cement	Smooth BUR Surface	Gravel Surfaced BUR	Existing Single-Ply
Insulation Required	Yes	No	No	No	No	No	No	Yes	No
Recommended Insulations	Carlisle Polyiso, DensDeck®, SECUROCK® or SecurShield® HD over acceptable insulation						← Refer to New Construction		
Insulation Attached By	Flexible FAST Adhesive or Carlisle HP Fasteners						← Refer to New Construction		
Membrane Attached By	Flexible FAST Adhesive						← Refer to New Construction		

FOR TEAR OFF OPTIONS REFER TO NEW CONSTRUCTION ABOVE.
 For current code approvals and warranties, visit Carlisle's web site or contact a design analyst.

Warranty Options 20 year warranty min.

Mil-Thickness	Warranty Length	Accidental Puncture Coverage with Flexible FAST at Full Coverage	Hail Coverage with Flexible FAST at Full Coverage
115-mil	15 or 20 year	16 man-hours per year	Up to 2" diameter hail
135-mil	25 year	32 man-hours per year	Up to 3" diameter hail

- » A 10-, 15-, 20-, or 25-year Golden Seal™ Total System Warranty may be requested when all materials used for the roofing installation are manufactured or marketed by Carlisle
- » A maximum peak gust wind speed coverage of 120mph is available with design enhancements
- » For projects specified with warranties greater than 20 year and/or wind coverage specified greater than 80mph, additional design enhancements are required
- » Refer to Carlisle's currently published specifications and details for additional warranty information and specific requirements concerning the application of this roof

Product Data Sheets



FleeceBACK® PVC

Polyester Membrane



Overview

Carlisle's FleeceBACK PVC polyester reinforced membrane is tough, durable, and versatile, making it ideal for a wide variety of re-roofing and new construction projects. Manufactured using a hot-melt extrusion process for complete scrim encapsulation, this product is available in total sheet thicknesses of 115, and 135 mils.

FleeceBACK PVC polyester reinforced membrane offers exceptional weatherability, flexibility, and toughness due to its polyester reinforcing scrim and polyester fleece backing. The polyester reinforcing scrim provides the sheet with added breaking strength, tear strength and puncture resistance for fully adhered or mechanically attached applications; the fleece backing adds to the puncture-resistance of the membrane and provides a built-in separation layer against rough concrete decks or existing asphaltic-based roofing systems. Years of proven PVC formulation performance helps to ensure the membrane remains pliable and weldable as it ages.

Features and Benefits

- » Available in white, gray, light gray, slate gray, and tan and offered in 115- and 135-mil thicknesses
- » Roll Sizes: 115-mil = 10' x 100'
135-mil = 10' x 75'
- » Provides superior wind uplift performance and ratings (up to FM 1-990) due to a mechanical bond between the fleece and adhesive
- » Passes UL-2218 Class 4 rating
- » Labor-saving 10'-wide sheets result in 67% fewer seams than a modified bitumen system of comparable size
- » Polyester reinforcing scrim provides exceptional puncture strength

- » Low-volatility plasticizer in proven performance PVC formulation
- » Good chemical resistance to acids, bases, restaurant oils, fats, greases, and acid rain
- » ENERGY STAR®*-qualified, White and Light Gray KEE HP are California Title 24 compliant, can contribute to LEED® (Leadership in Energy and Environmental Design) credits.

Installation

Mechanically Fastened Roofing System

The mechanically fastened system starts with approved insulation being fastened with a minimum of 5 fasteners per 4' x 8' board. The FleeceBACK PVC membrane is then mechanically fastened to the deck using HP-X Fasteners and Piranha Plates or HP-XTRA Fasteners and Piranha XTRA Plates. Adjoining sheets of FleeceBACK PVC membrane are overlapped over the fasteners and plates and joined together with a minimum 1½"-wide hot-air weld.

Adhered Roofing System – Low Rise Foam

Insulation is mechanically fastened or adhered with Flexible FAST™ Adhesive to the roof deck. Spray-apply, splatter, or extrude adhesive onto the substrate, and allow foam to develop string/body/gel prior to setting FleeceBACK membrane into the adhesive. Roll FleeceBACK membrane with a 30"-wide, 150-pound (68 kg) segmented weighted roller to ensure full embedment. Splices are hot-air welded.

Adhered Roofing System – Water Based

The fully adhered system starts with a suitable surface on which to apply the HydroBond™ Water-Based Adhesive.

HydroBond can be applied to the approved substrate with a medium nap roller. Once the adhesive has been applied, roll the membrane in place. To prevent over-drying, Carlisle recommends applying the adhesive 3'–4' at a time ahead of the roll. Immediately broom the membrane starting from the center and working out to the sides of the sheet using a soft bristle push broom to work out any air bubbles. Immediately after brooming, roll the adhered membrane in two directions in a crossways pattern using a minimum 150-lb (68 kg) segmented membrane roller.

Review Carlisle specifications and details for complete installation information.

Supplemental Approvals, Statements, and Characteristics

FleeceBACK PVC Polyester Reinforced membranes meet or exceed the requirements of ASTM D4434 Standard Specification for Poly (Vinyl Chloride) Sheet Roofing. FleeceBACK PVC is classified as Type III or Type IV as defined by ASTM D4434.

FleeceBACK PVC

Polyester Membrane

Precautions

- » Use proper stacking procedures to ensure sufficient stability of the materials.
- » Exercise caution when walking on wet membrane; membranes may be slippery when wet.
- » Sunglasses which filter out ultraviolet light are strongly recommended since white surfaces are highly reflective to sunlight. Roofing technicians should dress appropriately and wear sunscreen.
- » White surfaces reflect heat and may become slippery due to frost and ice accumulation.
- » Care must be exercised when working close to a roof edge, particularly when the surrounding area is snow-covered, as the roof edge may not be clearly visible.
- » FleeceBACK membrane rolls must be tarped and elevated to keep them dry prior to installation. If the fleece gets wet, use a wet vac system to help remove moisture from the fleece.
- » PVC membrane that has been exposed to the weather must be prepared with Carlisle's PVC & KEE HP Membrane Cleaner prior to hot-air welding.

Radiative Properties for ENERGY STAR®, Cool Roof Rating Council (CRRC), and LEED

Physical Property	Test Method	White PVC	Tan PVC	Gray PVC	Light Gray PVC	Slate Gray PVC
ENERGY STAR - E-903 Initial Solar Reflectance	Solar Spectrum Reflectometer	0.86	0.73	0.59	0.74	N/A
ENERGY STAR - E-903 Solar Reflectance after 3 years	Solar Spectrum Reflectometer (Uncleaned)	0.63	Pending	Pending	Pending	N/A
CRRC - Initial Solar Reflectance	ASTM C1549	0.86	0.72	0.59	0.74	N/A
CRRC - Solar Reflectance after 3 years	ASTM C1549 (uncleaned)	0.63	0.60*	0.49*	0.64*	N/A
CRRC - Initial Thermal Emittance	ASTM C1371	0.89	0.87	0.89	0.88	N/A
CRRC - Thermal Emittance after 3 years	ASTM C1371 (uncleaned)	0.87	0.86*	0.86*	0.89*	N/A
Solar Reflective Index (SRI)	ASTM E1980	108	88	70	90	N/A
Solar Reflective Index (SRI) SRI after 3 years	ASTM E1980	75	71*	56*	77*	N/A

*Rapid Ratings

Typical Properties and Characteristics

Physical Property	ASTM D4434 Requirement	115-mil	135-mil
Thickness over fleece	No requirement	60-mil	80-mil
Membrane Thickness Over Scrim , in. (mm) ASTM D4434 optical method, average of 3 areas	0.016 min (0.40)	0.027 (0.686)	0.037 (0.940)
Weight , lbs/ft ² (kg/m ²)	No requirement	0.45	0.59
Breaking strength (MD x CD) , lbf/in (kN/m) ASTM D751 grab method	200 min (890)	420 x 380 (73 x 66)	450 x 410 (79 x 72)
Elongation break of reinforcement (MD x CD) , % ASTM D751 grab method	15 x 15 min For reinforcing fabric only	30 x 30	30 x 30
Tearing strength (MD x CD) , lbf (N) ASTM D751 proc. B, 8 in. x 8 in.	45 min (200)	197 x 165 (876 x 734)	173 x 191 (769 x 849)
Low temperature bend , ASTM D2135, no cracks 5x at -40°C	PASS	PASS	PASS
Linear dimensional change , % ASTM D1204, 6 hours at 176°F	± 0.5 max	0.4 typ.	0.4 typ.
Water absorption resistance , mass % ASTM D570, 166 hours at 158°F water	±3.0 max	2.0	2.0
Puncture resistance - Dynamic , J (ft-lbf) ASTM D5635	20 (14.7)	40 (29.5)	42.5 (31.3)
Puncture resistance - Static , lbf (N) ASTM D5602	33 (145)	63.99 (284.6)	63.99 (284.6)
Puncture Resistance - Federal Puncture (Max. Load in lbf) FTM 101C	No requirement	380	460
Xenon-Arc resistance , no cracks/crazing 10x, ASTM G155 0.35 W/m ² at 340-nm, 63°C B.P.T. 12,600 kJ/m ² total radiant exposure 10,000 hours	PASS	PASS	PASS
Properties after heat aging ASTM D3045, 56 days at 176°F	90 min	90 min	90 min
Breaking strength, % retained	90 min	90 min	90 min
Elongation reinf., % retained			

Typical properties and characteristics are based on samples tested and are not guaranteed for all samples of this product. This data and information is intended as a guide and does not reflect the specification range for any particular property of this product.

LEED® Information

Pre-consumer Recycled Content	10%
Post-consumer Recycled Content	0%
Manufacturing Location	Greenville, IL
Solar Reflectance Index (SRI), Initial	White: 108, Tan: 88, Gray: 70, Light Gray: 90, Slate Gray: N/A

DensDeck® Prime Roof Board



Overview

DensDeck Prime Roof Board's patented design features a gypsum core with embedded glass mat facers on the top and bottom of the board. DensDeck Prime can be used in a variety of commercial roof systems and provides an excellent thermal barrier as well as exceptional fire, moisture, and wind uplift resistance properties.

DensDeck Prime is typically used as a cover board over insulation in fully adhered EPDM, TPO, and PVC applications. It is compatible with solvent-based bonding adhesives. For applications in which Carlisle's FAST™, or Flexible FAST Adhesive is used to attach insulation and a vapor barrier is specified, DensDeck Prime can be used as a base layer for Carlisle's VapAir™ Seal 725TR Air and Vapor Barrier (in conjunction with CCW 702-LV or CAV-GRIP™ Primer). DensDeck Prime is also compatible with hot asphalt and can be used as a membrane underlayment in hot mopped roofing systems or as a parapet wall substrate in all systems.

Features and Benefits

- » UL code ratings available for high slopes and wood decks
- » FM Approved
- » Improves resistance to foot traffic and hail damage
- » Excellent wind uplift ratings
- » Resistant to deterioration, warping, and jobsite damage
- » 5/8" DensDeck Prime can replace any generic type "X" gypsum board in any roof assembly in the UL Fire Resistance Directory under the prefix "P"

Installation

DensDeck Prime may be secured with FAST Adhesive, fastened in accordance with an approved fastening pattern, or mopped with Type III or IV asphalt.

Edge joints should be located on and parallel to deck ribs. End joints of adjacent lengths should be staggered.

1. This material shall be installed with ends and edges butted tightly.
2. When installed over combustible wood decks or insulations, all joints should be staggered.
3. In accordance with approved shop drawings, FM Approved fasteners shall be installed with plates through the roof board, flush with the surface.
4. When attaching VapAir Seal 725TR, use DensDeck Prime in conjunction with CCW-702, 702-LV, or CAV-GRIP Primer.

Review Carlisle specifications and details for complete installation information.

FM Approvals 1-90 1/4" DensDeck Prime Cover Board

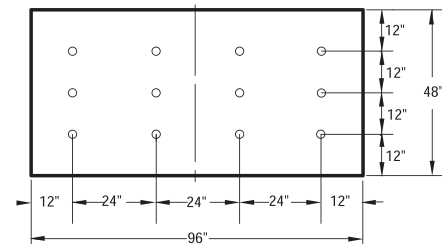

4' X 8' Boards
(12 fasteners per 4' x 8' board)

FM Approvals 1-90 1/2" or 5/8" DensDeck Prime Cover Board

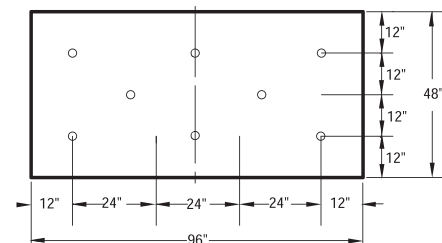

4' X 8' Boards
(8 fasteners per 4' x 8' board)

DensDeck Prime Roof Board

Precautions

- » Panels must be kept dry before, during and after installation. Apply only as much roof board as can be covered by roof membrane in the same day.
- » When applying solvent-based adhesives or primers, allow sufficient time for the solvents to flash off.
- » ¼" DensDeck Prime is not recommended for vertical parapet applications.
- » In ballasted roofing systems, DensDeck Prime is not an acceptable membrane underlayment.

Ratings and Certifications

- » Manufactured to conform to ASTM C-1177
- » Tested in accordance with ASTM E-84 or CAN/ULC-S102
- » Non-combustible when tested in accordance with ASTM E-136
- » UL Classified when tested in accordance with ASTM E-119

LEED® Information

Manufacturing Location ¹	Total Recycled Content ²	Pre-Consumer Recycled Content ²	Post-Consumer Recycled Content ²
Acme, TX	0%	0%	0%
Antioch, CA	0%	0%	0%
Ft. Dodge, IA	0%	0%	0%
Las Vegas, NV	0%	0%	0%
Lovell, WY	0%	0%	0%
Newington, NH	30%	30%	0%
Savannah, GA	0%	0%	0%
Tacoma, WA	14%	14%	0%
Wheatfield, IN	94%	94%	0%

¹ Manufacturing locations subject to change. Please visit www.gpgypsum.com and click on Sustainability.

² Recycled content subject to change +/- 1.0%.

³ Based on ICC Evaluation Service Verification of Attributes Report for Dens® brand products issued August 1, 2009. www.saveprogram.icc-es.org

Typical Properties and Characteristics

Properties	¼" (6.4 mm)	½" (12.7 mm)	¾" (15.9 mm)
Thickness, nominal	¼" (6.4 mm) ± ⅛" (1.6 mm)	½" (12.7 mm) ± ⅛" (.8 mm)	¾" (15.9 mm) ± ⅛" (.8 mm)
Width, standard	4' (1219 mm) ± ⅛" (3 mm)	4' (1219 mm) ± ⅛" (3 mm)	4' (1219 mm) ± ⅛" (3 mm)
Length, standard	4' (1219 mm) 8' (2438 mm) ± ¼" (6.4 mm)	4' (1219 mm) 8' (2438 mm) ± ¼" (6.4 mm)	4' (1219 mm) 8' (2438 mm) ± ¼" (6.4 mm)
Weight, nominal, lbs./sq. ft. (Kg/m ²) ⁷	1.2 (5.9)	2.0 (9.8)	2.5 (12.2)
Surfacing	Fiberglass mat with non-asphaltic coating	Fiberglass mat with non-asphaltic coating	Fiberglass mat with non-asphaltic coating
Flexural Strength ¹ , parallel, lbf. min. (N)	≥ 40 (178)	≥ 80 (356)	≥ 100 (444)
Flute Spanability ²	2⅝" (67 mm)	5" (127 mm)	8" (203 mm)
Permeance ³ , Perms (ng/Pa• S• m ²)	>30 (>1710)	>23 (>1300)	>17 (>970)
R Value ⁴ , ft ² • °F• hr/BTU (m ² • K/ W)	0.28	0.56	0.67
Linear Variation with Change in Temp., in/in °F (mm/mm/°C)	8.5 x 10 ⁻⁶ (15.3 x 10 ⁻⁶)	8.5 x 10 ⁻⁶ (15.3 x 10 ⁻⁶)	8.5 x 10 ⁻⁶ (15.3 x 10 ⁻⁶)
Linear Variation with Change in Moisture	6.25 x 10 ⁻⁶	6.25 x 10 ⁻⁶	6.25 x 10 ⁻⁶
Water Absorption ⁵ , %	5	5	5
Compressive Strength ⁶ , psi nominal ¹	900	900	900
Surface Water Absorption, grams, nominal	1.0	1.0	1.0
Flame Spread, Smoke Developed (ASTM E84)	0/0	0/0	0/0
Bending Radius	4' (1219 mm)	6' (1829 mm)	8' (2438 mm)

¹ Tested in accordance with ASTM C473 method B.

² Tested in accordance with ASTM E661.

³ Tested in accordance with ASTM E96 (dry cup method).

⁴ Tested in accordance with ASTM C518 (heat flow meter).

⁵ Tested in accordance with ASTM C1177.

⁶ Tested in accordance with ASTM C473.

⁷ Represents approximate weight for design and shipping purposes. Actual weight may vary based on manufacturing location and other factors.

InsulBase[®] POLYISO

Insulation



Overview

InsulBase is a rigid-roof insulation panel composed of a closed-cell polyisocyanurate foam core bonded on each side to glass-reinforced felt (GRF).

Features and Benefits

- » InsulBase polyiso insulation provides the highest R-value per inch of commercially available insulation products
- » Environmentally friendly construction with 0% ozone-depleting components and CFC free
- » Approved for direct application to steel decks

Panel Characteristics

- » Available in 4' x 4' (1220 mm x 1220 mm) and 4' x 8' (1220 mm x 2440 mm) panels in thickness of ½" (13 mm) to 4.5" (115 mm)

Applications

- » Single-Ply Roof Systems (Ballasted, Mechanically Attached, Fully Adhered)

InsulBase Polyiso Thermal Values

Thickness (inches)	Thickness (MM)	LTRR R-value	Flute Spanability
0.50	13	2.8	2 5/8"
1.00	25	5.7	2 5/8"
1.50	38	8.6	4 3/8"
2.00	51	11.4	4 3/8"
2.50	64	14.4	4 3/8"
3.00	76	17.4	4 3/8"
3.50	89	20.5	4 3/8"
4.00	102	23.6	4 3/8"
4.50	114	26.8	4 3/8"

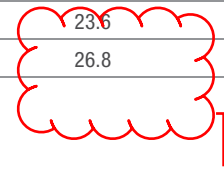

Installation

Ballasted Single-Ply Systems

R30 min.

Each InsulBase panel is loosely laid on the roof deck. Butt edges and stagger joints of adjacent panels. Install the roof membrane according to Carlisle's specifications.

Mechanically Attached Single-Ply Systems

InsulBase panels must be secured to the roof deck with fasteners and plates (appropriate to the deck type). Butt edges and stagger joints of adjacent panels. Install the roof membrane according to Carlisle's specifications.

Fully Adhered Single-Ply Systems

InsulBase panels must be secured to the roof deck with fasteners and plates (appropriate to deck type). Butt edges and stagger joints of adjacent panels. Install the roof membrane according to Carlisle's specifications.

InsulBase 4' x 8' panels can be secured to the roof deck with Carlisle's FAST[®] Adhesive, either full coverage or bead spacing.

InsulBase 4' x 4' panels may be adhered to prepared concrete deck with a full mopping of Type III or IV asphalt.

Review Carlisle specifications and details for complete installation information.

InsulBase POLYISO

Insulation

Codes and Compliances

- » ASTM C1289, Type II, Class 1, Grade 2 (20 psi), Grade 3 (25 psi)
- » International Building Code (IBC) Section 2603
- » UL Standard 790, 263 and 1256: Component of Class A Roof Systems (refer to UL Roof Materials' system directory)
- » FM® Standards 4450/4470: Class 1 approval for steel roof-deck constructions (refer to FM RoofNavSM)
- » California Code of Regulations, Title 24, Insulation Quality Standard License #TI-1418
- » Third-party certification with the PIMA Quality Mark for Long-Term Thermal Resistance (LTTR) values
- » CAN/ULC S704, Type 2 & 3, Class 2
- » Florida Building Code Approval

Precautions

Insulation must be protected from open flame and kept dry at all times. Install only as much insulation as can be covered the same day by completed roof-covering material. Protect installed product from excessive foot traffic. Carlisle will not be responsible for specific building and roof design by others, for deficiencies in construction or workmanship, for dangerous conditions on the job site or for improper storage and handling. Technical specifications shown in this literature are intended to be used as general guidelines only and are subject to change without notice. Call Carlisle for more specific details, or refer to PIMA Technical Bulletin No. 109: Storage & Handling Recommendations for Polyiso Roof Insulation.

Typical Properties and Characteristics (ASTM C1289)

Physical Property	Test Method	Value
Compressive Strength	ASTM D1621	20 psi* minimum (138 kPa, Grade 2)
Dimensional Stability	ASTM D2126	2% linear change (7 days)
Moisture Vapor Permeance	ASTM E96	<1 perm (57.5 ng/(Pa•s•m ²))
Water Absorption	C1763	<1% volume

Typical properties and characteristics are based on samples tested and are not guaranteed for all samples of this product. This data and information is intended as a guide and does not reflect the specification range for any particular property of this product.

*Also available in 25 psi minimum, Grade 3



Foamed plastic as roof deck construction material with resistance to an internal fire exposure only for use in construction no.(s) 120 and 123. See UL Directory of Products Certified for Canada and UL Roofing Materials and Systems Directory. 99DL.



Sure-Flex™ PVC

Contour Rib™ Profile

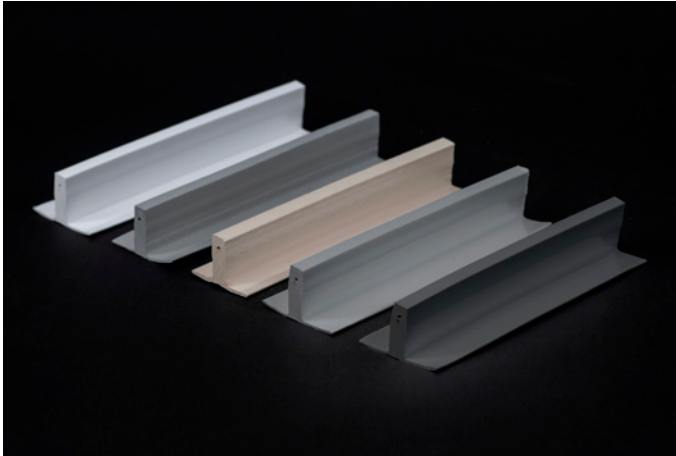

Overview

Obtain the look of standing seam metal roofing with the performance of a PVC single-ply membrane with the Carlisle Contour Rib Profile. This profile is extruded from the same weather-resistant PVC compound as the membrane. The Contour Rib Profile is secured to the PVC roofing membrane to simulate a standing seam metal roofing system. The physical dimensional stability of the profile is enhanced with fiberglass and the rectangular profile provides exceptional shadow lines for aesthetic appeal. Available in White, Gray, Tan, Light Gray and Slate Gray.

The Contour Rib Profile measures 1¼" tall and 2½" wide including the welding flanges while the vertical profile is a substantial ⅜" thick. The profile has an ⅛" alignment hole as well as an ⅛" fiberglass reinforcing cord. The Contour is available in 10' lengths packaged 20 per carton. Twenty-five (25) connecting pins are also included in the carton.

Features and Benefits

- » Available in white, gray, tan, light gray and slate gray
- » Same weatherability as membrane
- » Improves aesthetics of sloped roofs
- » Zero maintenance
- » Lower cost than conventional metal roofing
- » Flexible heat-weldable flange allows easy welding of the profile to the roofing membrane

- » Fiberglass reinforcement adds dimensional stability
- » Low-volatility plasticizer
- » Creative installations allow for building design features
- » Proper installation does not affect watertight integrity of membrane
- » Non-penetrating application

Installation

The Sure-Flex PVC Contour Rib Profile is designed for use with FleeceBACK PVC adhered roofing systems, but may also be used with adhered Sure-Flex PVC systems. Ensure that all welding surfaces are clean and dry.

Method 1 – Using a standard autowelder and hand welding

Method 2 – Using the Hapco, Inc. Standing Seam Profile Wheel Kit Part Number 107081C2

Review Carlisle specifications and details for complete installation information.

Precautions

- » Use proper stacking procedures for cartons to ensure sufficient stability.
- » Exercise caution when walking on wet membrane.
- » Sunglasses that filter out ultraviolet light are strongly recommended as the membrane's white surface is highly reflective to sunlight. White surfaces reflect heat and light. Roofing technicians should dress appropriately and wear sunscreen to protect skin from the sun.
- » White surfaces reflect heat and may become slippery due to frost and ice accumulation.
- » Care must be exercised when working close to a roof edge when the surrounding area is snow covered.
- » Sure-Flex PVC membrane exposed to the weather must be prepared with Carlisle PVC Membrane Cleaner prior to hot-air welding.

Sure-Flex PVC

Contour Rib Profile

Typical Properties and Characteristics (Per purchasing spec)

Length (inches)	120 ± ¼
Weight/Ln Ft (lb)	0.40
Weight/Piece (lb)	4.2
Height (inches)	1.25 ± ³ / ₁₀₀
Width (inches)	2.125 ± ¹ / ₂₅
Pieces/carton	20
Connecting pins/carton	25

Typical properties and characteristics are based on samples tested and are not guaranteed for all samples of this product. This data and information is intended as a guide and does not reflect the specification range for any particular property of this product.

LEED® Information

Pre-consumer Recycled Content	10%
Post-consumer Recycled Content	0
Manufacturing Location	Mount Airy, NC

Sure-Flex™ KEE HP

Roofing System Accessories

A ready reference guide for ordering accessories for your next PVC and KEE HP job.



Molded Sealant Pockets

Interlocking, two-piece, injection-molded, weldable pockets used to waterproof pipe clusters or other oddly shaped penetrations.

Sizes Available: 6" wide x 2" high. Can be adjusted from 7½" to 11½" in length.

Quantity Per Box: 5 complete pockets

Manufactured using PVC.



Split Pipe Seals

Fabricated flashings made of 60-mil reinforced Sure-Flex membrane used for flashing pipes with an obstruction that prevents the use of a molded pipe seal.

Sizes Available: 1", 2", 3", 4", 5" and 6" diameter. Other sizes and colors available through special order.

Quantity Per Box: 8



Molded Pipe Seals

Injection-molded, pre-formed flashings.

Sizes Available: ¾" to 8" diameter

Colors Available: White, Gray, Tan

Quantity Per Box: 8



Square Tubing Wraps

Fabricated using 60-mil reinforced Sure-Flex membrane and are designed to flash square metal tubing. A split and overlap tab are incorporated into these parts to allow the flashings to be opened and wrapped around a square penetration with an obstruction.

Sizes Available: 3" x 3", 4" x 4", and 6" x 6". Other sizes and colors available through special order.

Quantity Per Box: 8



Flashing

Non-reinforced, 80-mil Sure-Flex membrane used to field-fabricate pipe flashing, sealant pockets and scuppers when the use of a pre-molded accessory is not feasible.

Sizes Available: 12" x 50' and 24" x 50'

Colors Available: White, Gray/Tan

Quantity Per Box: 1 roll



Reinforced Coverstrip

Pre-slit, reinforced membrane used to strip-in fasteners and plates and to cover end laps on FleeceBACK® membranes.

Sizes Available: 8" x 80' (60-mil KEE HP reinforced), 8" x 65' (80-mil KEE HP reinforced), 8" x 65' (80-mil PVC reinforced)

Colors Available: White, Gray, Tan

Quantity Per Box: 2 rolls (60-mil), 1 roll (80-mil)



Walkway Rolls

Heat-weldable walkway rolls designed to protect Sure-Flex PVC and KEE membranes in areas exposed to repetitive foot traffic and other hazards.

Sizes Available: 36" x 60' (Gray)

Packaged Individually

Manufactured using PVC.



1 - Outside Corners

2 - Inside Corners

Pre-molded and used for flashing inside and outside corners of a variety of details.

Colors Available: White, Gray/Tan

Quantity Per Bag: 12



T-Joint Covers

Injection-molded, non-reinforced flashings used to seal T-Joint splice intersections.

Sizes Available: 4.5" diameter

Colors Available: White, Gray, Tan

Quantity Per Box: 100



Curb Wrap Corners

Fabricated flashings made of 60-mil reinforced Sure-Flex membrane designed to reduce curb flashing time. One curb will require 4 corners.

Sizes Available: 7" Wrap for 12" Curb, 13" Wrap for 24" Curb, 19" Wrap for 36" Curb. Other sizes and colors available through special orders. Can also be ordered in 1- or 2-piece wraps.

Quantity Per Box: 12 pieces or 3 complete curbs



Overlayment Strip

Carlisle Sure-Flex PVC Overlayment Strip is an 80-mil (2 mm) non-reinforced thermoplastic poly (Vinyl Chloride) based membrane.

Sizes Available: 6" by 100' rolls

Colors Available: White, Gray/Tan

Quantity Per Box: 2 rolls



All Sure-Flex PVC/KEE HP accessories come with a Certified Fabricated Accessory (CFA) stamp of approval. This signifies that it meets the stringent quality requirements to be labeled as a Carlisle product and included on warranted projects.

FASTENERS & PLATES

Carlisle SynTec Systems offers an array of fasteners and plates to complement our roofing systems. From pre-assembled choices for EPDM installations to Purlin fasteners for Metal Retrofit Systems and Piranha plates for Sure-Weld® options, our mission continues to be to provide all components necessary for the application of a long-lasting and secure single-ply roofing system from Carlisle.

 Sure-Seal® & Sure-White® EPDM

 Sure-Weld TPO

 Sure-Flex™ PVC

HP FASTENER

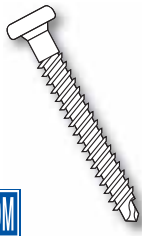

Applicable to steel, 22-gauge and heavier, CDX plywood and wood plank deck types. Can be used to secure Sure-Tough membranes, RUSS and insulation. Longer fastener sizes available as special order.

Sizes Available:
1 1/4", 2"– 15" (1" Increments)

Size & Quantity Per Box:
2"– 6": 1,000; 7"– 12": 500; 13"– 15": 250
1 1/4": 1,000



CD-10

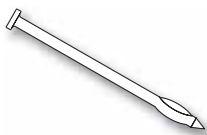

Applicable for concrete decks. Used to secure Sure-Seal, Sure-Weld and Sure-Flex membranes and for insulation securement.

Sizes Available:
2"– 6" (1/2" Increments)
7"– 12" (1" Increments)

Size & Quantity Per Box:
2"– 8": 500; 9"– 12": 250



HP-X FASTENER™ & HP-XTRA FASTENER



A #15 diameter fastener applicable to steel, wood and CDX plywood. Can be used to secure Sure-Seal, Sure-Weld and Sure-Flex membranes.

Sizes Available:
2"– 8" (1" Increments)
10"– 16" (2" Increments)

Size & Quantity Per Box:
2"– 4": 1,000; 5"– 12": 500; 14"– 16": 250



Size & Quantity Per Box:
500 (2" – 6"), 250 (7" – 8")

HP-XTRA FASTENER
Also Available (Not shown)

A #21 diameter fastener applicable to steel, wood and CDX plywood decks.

Sizes Available:
2" – 8" (1" increments)

INSULFAST™



A #12 diameter fastener applicable to wood decks and steel, 22-gauge and heavier, decks. Used only for insulation attachment.

Sizes Available:
2"– 8" (1" Increments)
1 5/8", 2 1/4", 3"– 8" (1" Increments)

Size & Quantity Per Box:
2"– 8": 1,000

SURE-TITE®



A 0.33" diameter fastener applicable to steel, 22-gauge and heavier. Can be used for Sure-Tough membrane securement in mechanically attached systems.

Sizes Available:
2"– 8" (1" Increments)

Size & Quantity Per Box:
2", 3": 500; 4"– 8": 250



HD 14-10

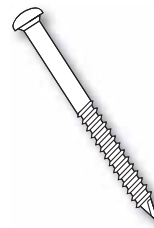

A #14 diameter fastener used for Sure-Tough, Sure-Weld and Sure-Flex membrane securement into wood and concrete decks. Also applicable to insulation securement into steel, wood and concrete decks.

Sizes Available:
2"– 12" (1" Increments)
14"– 24" (2" Increments)

Size & Quantity Per Box:
2"– 4": 1,000; 5"– 11": 500; 12"– 24": 250



GYPTEC FASTENER & PLATE

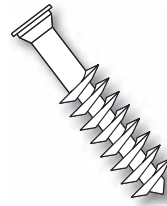

Applicable to cementitious wood fiber, lightweight concrete and gypsum decks. Can be used to secure Sure-Tough, Sure-Weld and Sure-Flex membranes and insulation.

Sizes Available:
2 1/2"– 10" (1/2" Increments)

Size & Quantity Per Box:
2 1/2"– 7": 500; 7 1/2"– 10": 250



GYPTEC PLATE

Sizes Available:
2" Metal membrane plate
3" Metal insulation plate
Quantity Per Box: 1,000

Experience the Carlisle Difference

800-479-6832 • P.O. Box 7000 • Carlisle, PA 17013 • Fax: 717-245-7053 • www.carlisesyntec.com

CARLISLE
SYNTEC SYSTEMS

FASTENERS & PLATES

ASAP WITH POLYMER PLATE

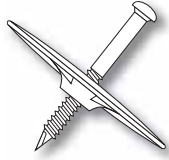

A pre-assembled #12 diameter fastener and plastic insulation plate applicable to steel and wood decks. Used to secure insulation only. Longer fastener sizes available as special order.

Sizes Available:
2¼", 3"– 12" (1" Increments)
Size & Quantity Per Box:
2¼"– 8": 250; 9"– 12": 200

HP-X ASAP

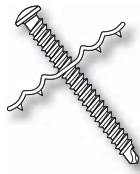

A pre-assembled HP-X Fastener and Piranha Plate™ applicable to steel, wood and CDX plywood decks. Used to secure Sure-Weld and Sure-Flex membranes.

Sizes Available:
2"–10" (1" Increments)
12"–16" (2" Increments)
Size & Quantity Per Box:
2"– 9": 250; 10"– 12": 200; 14"– 16": 150



HP PRE-ASSEMBLED



Pre-assembled HP Fastener and Polymer seam plate applicable to steel, wood and CDX plywood decks. Used to secure Sure-Tough membranes.

Sizes Available:
2¼", 3"– 12" (1" Increments)
Size & Quantity Per Box:
2¼", 3", 3¾", 3¾": 450; 4", 5": 400; 6": 350;
7", 8": 300; 9": 250; 10"– 12": 200



RHINO BOND® PLATE



3"-round, specially coated plates used with HP-X Fasteners and the RhinoBond induction welding system. Available in TPO and PVC versions.

Sizes Available:
3" diameter
Quantity Per Box: 500/carton



HP POLYMER SEAM PLATE

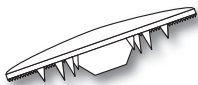

Along with the HP Fastener, used to mechanically fasten reinforced Sure-Tough membrane and RUSS over steel decks.

Sizes Available:
2" diameter
Quantity Per Box: 1,000



PIRANHA PLATE

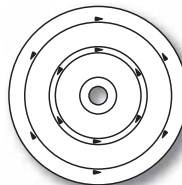

Along with the appropriate fastener, used to secure Sure-Weld and Sure-Flex membranes to steel, concrete and wood decks.

Sizes Available:
2¾" diameter
Quantity Per Box: 1,000



HP-XTRA POLYMER SEAM PLATE

Also Available (Not shown)

For use with HP-XTRA Fastener to secure Sure-Tough membranes to steel decks.

Sizes Available:
2¾" diameter
Quantity Per Box: 1,000

HP-XTRA PIRANHA PLATE

Also Available (Not shown)

For use with HP-XTRA Fastener to secure Sure-Weld and Sure-Flex membranes to steel and wood decks.

Sizes Available:
2¾" diameter
Quantity Per Box: 1,000

SEAM FASTENING PLATE

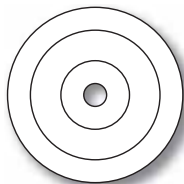

Applicable with HP, HD 14-10 and CD-10 fasteners to mechanically attach reinforced Sure-Tough membrane (excluding steel decks) and RUSS (except when used with mechanically fastened EPDM to steel decks).

Sizes Available:
2" diameter
Quantity Per Box: 1,000



INSULATION FASTENING PLATE

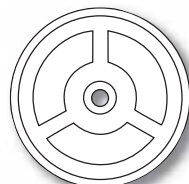

Applicable with InsulFast, HP, CD-10 and HD 14-10 fasteners. Used for insulation securement only on steel, wood and concrete decks.

Sizes Available:
3" diameter
Quantity Per Box: 1,000

Experience the Carlisle Difference

800-479-6832 • P.O. Box 7000 • Carlisle, PA 17013 • Fax: 717-245-7053 • www.carlisesyntec.com

Carlisle, Sure-Seal, Sure-Weld, FleeceBACK, Sure-Flex, Sure-White, HP-X Fastener, InsulFAST, Sure-Tite and RUSS are trademarks of Carlisle. RhinoBond is a registered trademark of OMG, Inc.

REPRINT REQUEST CODE: 600269 - Fasteners & Plates Product Data Sheet - 02.19.13 © 2013 Carlisle.

CARLISLE
SYNTEC SYSTEMS

Sure-Flex™ PVC

HydroBond™ Water-Based Adhesive



Overview

Carlisle's HydroBond PVC Water-Based Adhesive is a wet lay-in, one-sided dispersion adhesive. Compatible with TPO, PVC, and KEE HP FleeceBACK® membranes, this product is ideal for bonding only PVC membranes to various porous and non-porous substrates (**cannot be used with any KEE or KEE HP bareback membranes**). See coverage rates chart for acceptable substrates. HydroBond is used to secure PVC membranes to clean and dry horizontal surfaces with up to a 2:12 slope and as a contact adhesive in vertical applications. This water-based adhesive is specially formulated to be in compliance with the state of California Clean Air Act of 1988 (updated in 1997) and as further regulated by California's Air Quality Control District's listing of VOC limitations. HydroBond also meets the requirements of the OTC Model Rule for Single-Ply Roofing Adhesives.

Features and Benefits

- » Long-lasting, high-strength bond
- » One-sided wet lay-in application saves time and labor
- » Quickly and easily applied with a medium nap roller
- » 12-month shelf life (sealed container)
- » No HAZMAT restrictions

Coverage Rates

Acceptable Substrates	Coverage Rates	
	Roller (SF/Gallon)	Spray (SF/Gallon)
Smooth-Backed Membrane		
Polyiso - Paper or Glass Facer	100	133
Gypsum Cover Boards	100	133
Plywood	100	133
FleeceBACK Membrane		
Polyiso - Paper or Glass Facer	100	133
DensDeck®	100	100
DensDeck Prime®/SECUROCK®	100	133
Plywood	100	133

Application

1. The surface on or against which the adhesive is to be applied shall be clean, smooth, dry, free of fins, sharp edges, loose and foreign materials, oil, and grease. Depressions greater than ¼" (6 mm) shall be feathered using epoxy, mortar, or another approved patching material. All sharp projections shall be removed by sweeping, blowing, or vacuum cleaning.
2. HydroBond can be applied directly to the substrate using an airless spray machine or a medium nap roller. Do not apply HydroBond to splice areas to be hot-air welded. When applying HydroBond, ensure that the adhesive has not dried before the membrane is laid in place. This is a wet lay-in adhesive; drying occurs rapidly during high temperatures, and care must be taken to ensure the membrane is laid into wet adhesive. To ensure a wet lay-in, adjust the application technique according to weather conditions. Avoid heavy or thin application of adhesive. Roll the membrane into the wet, adhesive-coated substrate while avoiding wrinkles. Immediately brush down the bonded portion of the membrane with a soft-bristle push broom or a clean, dry roller applicator to achieve maximum contact and to work out any air bubbles. Immediately after brooming out from the center, roll the membrane in all directions with a minimum 100–150-lb (45–68 kg) weighted roller to achieve maximum contact. Pay particular attention to rolling the membrane along the insulation joints, especially on DensDeck Prime, due to the slight step-off of the facer.

Sure-Flex PVC

HydroBond Water-Based Adhesive

Standard Membrane (vertical walls two-sided contact method):

3. First, apply a medium to heavy coat of adhesive to the wall, and then apply a standard coat to the flashing membrane and allow to tack or string. Allowing the adhesive to dry will result in no adhesion strength. Avoiding wrinkles, mate the membrane with the adhesive-coated wall. Immediately broom the bonded portion of the sheet with a stiff-bristle push broom and roll the membrane, starting in the angle change and working the membrane up the wall. Use a 3"-wide "J" roller (preferred) to achieve maximum contact. Roll up from the base evenly and work in small sections, ensuring full attachment at the lower portions before moving to the top of the membrane. Until the termination detail can be completed, it may be necessary to temporarily pin or tape the top membrane edge to the wall to prevent membrane curl-back.

Review Carlisle specifications and details for complete application information.

Precautions

- » Review the applicable Material Safety Data Sheet for complete safety information prior to use.
- » Keep container closed when not in use. Use with adequate ventilation.
- » If swallowed, DO NOT INDUCE VOMITING. Call a physician immediately.
- » Avoid contact with eyes. Safety glasses or goggles are recommended. If splashed in eyes, immediately flush eyes with plenty of water for at least 15 minutes. Contact a physician immediately.
- » Avoid contact with skin. Occasional contact with hands or skin does not result in significant irritation unless it is not allowed to evaporate. Prolonged contact may cause irritation and dermatitis. Wash your hands thoroughly after handling.
- » Jobsite storage temperatures in excess of 99°F (37°C) may affect product shelf life. DO NOT ALLOW PRODUCT TO FREEZE. Do not store below 40°F.
- » Do not thin the HydroBond Adhesive. Thinning will affect performance.
- » Adhesive will dry quickly in dry, hot climates, drying will affect adhesion. Dry time is dependent on ambient conditions.
- » This adhesive is to be applied when the ambient temperature is 40°F (4°C) and rising. Do not apply if ambient temperature will drop below 32°F (0°C) before adhesive completely dries (normally 72 hours, longer if colder).
- » **Do not use with KEE or KEE HP bareback membranes**
- » Extended drying times can be expected in cool or humid conditions as

well as shaded areas. Not allowing the adhesive to dry in a standard membrane application will result in poor adhesion strength or blistering over time.

- » KEEP OUT OF THE REACH OF CHILDREN.

Typical Properties and Characteristics

Property	Value
Color	Light tan
Average Net Weight	9 lbs/gal
Packaging	5-gal pail
Shelf Life	1 year

Typical properties and characteristics are based on samples tested and are not guaranteed for all samples of this product. This data and information is intended as a guide and does not reflect the specification range for any particular property of this product.

LEED® Information

Pre-consumer Recycled Content	N/A
Post-consumer Recycled Content	N/A
VOC Content	Less than 120.5 g/l
Manufacturing Location	Ohio

Flexible FAST™ Adhesive



Overview

Carlisle pioneered and patented the VOC-free, energy-absorbing, impact-resistant Flexible FAST Adhesive for use with FleeceBACK® membranes and to secure insulation boards to the deck for a totally non-penetrating system application. This industry-leading breakthrough in urethane adhesive technology offers built-in elongation and energy-absorbing properties that work in conjunction with the FleeceBACK membrane to enhance puncture and hail resistance. Flexible FAST Adhesive is applied in full spray, splatter, or extrusions to deliver the two components onto the substrate. Parts A & B are mixed in the spray gun and applied to the roof. A catalytic reaction takes place, causing the Flexible FAST Adhesive to expand and foam. FleeceBACK membrane is then laid into the foamed adhesive after developing “string/body” and rolled with a 150-lb. segmented roller to ensure the fibers of the fleece are embedded into the adhesive. Within 20 minutes, Flexible FAST Adhesive cures to form a tenacious bond between the substrate and the FleeceBACK membrane.

Features and Benefits

» Added Puncture Resistance

In side-by-side dynamic puncture tests, Flexible FAST Adhesive increased puncture resistance between 33–50% compared to traditional competitive 2-component low-rise adhesives. The energy absorbing nature of the Flexible FAST foam makes this an ideal product for use in Roof Garden, Plaza Paver and Solar Panel applications in conjunction with FleeceBACK membrane.

» FM approved

» Energy Efficient and Environmentally Sound

Each layer of Flexible FAST Adhesive expands to 1/16"–1/8"-thick and provides an additional R-value of 0.20 to 0.50 per layer. The NRCA estimates that up to 10% of R-value can be lost due to joints in the insulation. The expanding nature of Flexible FAST adhesive helps to seal insulation joints, when Flexible FAST Adhesive is specified for insulation attachment in place of mechanical fasteners, the 3–8% loss in R-value can be eliminated. Water is used as the blowing agent in Flexible FAST Adhesive, making it VOC compliant and not labeled as a flammable product.

» Superior Wind Uplift

Superior wind uplift resistance is delivered with uplift pressures ranging from 90–945 psf depending on the substrate. Due to its superior wind uplift performance, the FleeceBACK/Flexible FAST Adhesive System can qualify for upgraded wind speed warranties of 80–120 mph with design enhancements. **Contact Carlisle SynTec Systems for design enhancement requirements.**

» Expedient Installations without Interruption

Due to the low noise and low odor associated with the system, the FleeceBACK/Flexible FAST assembly is an excellent choice for re-roofing occupied buildings, as there is minimal disruption. Because of these benefits, schools, universities and hospitals are some of the biggest users of the FleeceBACK/Flexible FAST assembly. The speed of application with Flexible FAST Adhesive affords project completion in a timely manner. Flexible FAST offers a significant reduction in free MDI: from 32% to 23% compared to traditional urethane adhesives.

» System Warranties

A full range of system warranties are available including 10-, 15-, 20-, and 30-year terms, which are No Dollar Limit, transferable and not voided for ponded water. In summary, the combination of 50 years of single-ply experience, fleece backing reinforcement, and Carlisle's impact-resistant adhesive technology results in an extremely tough and durable roofing composite system with superior wind uplift performance that can be applied with minimal business disruption and no deck penetrations.

Productivity Boosting Features and Benefits:

- » Reduces membrane application time up to 93% when compared to traditional installations using bonding adhesives on non-FleeceBACK systems
- » Eliminates the need to pre-drill into concrete and gypsum decks
- » 15- and 50-gallon drums reduce empty adhesive container stoppage time by 67%-90% when compared to Bag-in-a-Box



Flexible FAST Adhesive

Application

- The surface to which adhesive is to be applied shall be dry and free of fins, protrusions, sharp edges, loose and foreign materials, oil and grease. Depressions greater than ¼" (6 mm) shall be filled with Flexible FAST Adhesive or other approved patching material. All sharp projections shall be removed. **Previously unweathered asphalt must be primed with CAV-GRIP™ III.**
- Seal gaps between the wall/penetration and concrete deck with Carlisle 725TR, Flashing Foam, or other suitable material, to avoid condensation issues and positive pressure from air infiltration.**
- For reroofing sprayed-in-place (SPF) urethane roofs, all wet areas must be removed. The surface must then be scarified or perforated, depending on the coating, before applying Flexible FAST Adhesive.
- Apply Flexible FAST Adhesive when the substrate and ambient temperatures are 25°F (-4°C) or above when spraying or extruding with heated or non-heated equipment. Dispense the adhesive between 300-800 psi depending on the equipment used. Consult with your local FleeceBACK Specialist for more details.
- Set pre-heater and hose temperature to 120°F (49°C). Temperature settings will vary with conditions.

FleeceBACK Installation

Slide-in Method:

- Unroll FleeceBACK sheet and position. Fold the sheet back in half lengthwise (end-to-end).
- Spray-apply, splatter, or extrude Flexible FAST Adhesive to the substrate.
 - For full spray applications, spray adhesive at 1-gallon per square to obtain full coverage (approximately ¼ to ½ thick after foaming). Ensure membrane end laps are protected from adhesive.
 - For splatter applications, spray adhesive at ½ gallon per square to obtain 50% coverage (approximately ¼ to ½ thick after foaming). Ensure membrane end laps are protected from adhesive.
 - For extruded applications, apply at 4", 6", or 12" on center with a minimum ½" bead. Ensure membrane end laps are protected from adhesive.
- Once "string time" occurs, gradually feed FleeceBACK sheet into Flexible FAST Adhesive, checking for "string/body" every few feet. Stop feeding FleeceBACK sheet into adhesive when applicator reaches adhesive that has NOT developed "string/body". Immediately begin to roll membrane width-wise with a 150-lb. segmented weighted roller. Repeat process until FleeceBACK sheet is fully installed.

Roll-in (Mod Bit) Method:

- Keeping the FleeceBACK sheet on the core, position roll of FleeceBACK membrane at the designated starting point.

- Spray-apply, splatter, or extrude Flexible FAST Adhesive to the substrate.
 - For full spray applications, spray adhesive at 1-gallon per square to obtain full coverage (approximately ¼ to ½ thick after foaming). Ensure membrane end laps are protected from adhesive.
 - For splatter applications, spray adhesive at ½ gallon per square to obtain 50% coverage (approximately ¼ to ½ thick after foaming). Ensure membrane end laps are protected from adhesive.
 - For extruded applications, apply at 4", 6", or 12" on center with a minimum ½" bead. Ensure membrane end laps are protected from adhesive.
- Once "string time" occurs, gradually roll FleeceBACK membrane into Flexible FAST Adhesive, checking for "string/body" every few feet. Stop rolling FleeceBACK into adhesive when applicator reaches adhesive that has NOT developed "string/body". Immediately begin to roll membrane width-wise with a 150-lb. segmented weighted roller. Repeat process until FleeceBACK sheet is fully installed.

Insulation Attachment

- Apply Flexible FAST Adhesive to the substrate achieving a light-blue-colored foam.
 - For full spray applications, spray adhesive at 1-gallon per square to obtain full coverage (approximately ¼ to ½ thick after foaming). Ensure membrane end laps are protected from adhesive.
 - For splatter applications, spray adhesive at ½ gallon per square to obtain 50% coverage (approximately ¼ to ½ thick after foaming). Ensure membrane end laps are protected from adhesive.
 - For extruded applications, apply at 4", 6", or 12" on center with a minimum ½" bead. Ensure membrane end laps are protected from adhesive.

Bead Spacing parameters for 5-, 10-, or 15-year 55-mph warranties: (Contact Carlisle Project Review for bead spacing on higher mph warranties or 20- and 30-year warranty projects).

Building Height	Bead Spacing (Perimeter)	Bead Spacing (Field)
0' – 25'	6" o.c. (4' perimeter)	12" o.c.
25' – 50'	6" o.c. (8' perimeter)	12" o.c.
50' – 75'	6" o.c. (12' perimeter)	12" o.c.
75' – 100'	6" o.c. (16' perimeter)	12" o.c.
100' or greater: Contact Carlisle for bead spacing requirements		

- Factory Mutual bead spacing guidelines in the perimeter and corner may differ from the table above. Beads at 12" o.c. are not acceptable at perimeters and corners.
- Allow Flexible FAST Adhesive to rise and develop "string/body" (approx. 1½–2 min.). String time will vary based on environmental

conditions like temperature and humidity. Do not allow the adhesive to over-cure prior to setting insulation boards.

4. Place insulation boards (maximum 4' x 4' insulation boards when adhesive is extruded at 12" o.c. or when boards exceed 4" thickness, or 4' x 8' insulation boards when adhesive is applied in full spray, 4", or 6" beads) into adhesive after allowing it to rise and develop "string/body". String time will vary based on environmental conditions like temperature and humidity. Do not allow the adhesive to over-cure prior to setting insulation boards.
5. Designate one person to walk boards into place and then roll the boards between 5–7 minutes from the initial adhesive application. Boards may be temporarily weighted or relief-cut where necessary to keep the boards in constant contact with the adhesive until the adhesive cures.
6. At the beginning of the insulation attachment process and periodically throughout the day, check the adhesion of boards to ensure a tight bond is created and maximum contact is achieved.

Review Carlisle specifications and details for complete application information.

Precautions

- » Review the Safety Data Sheet for complete safety information prior to use.
- » The foam produced is an organic material. It must be considered as combustible and may constitute a fire hazard. The foam adhesive must not be left exposed or unprotected. Shield from heat and sparks.
- » Do not smoke during application.
- » Use with adequate ventilation. Avoid breathing vapors. Wear a NIOSH- or MSHA-approved respirator for organic vapors with prefilters and solvent-resistant cartridges or supplied airline respirators while spraying. Proper safety training is essential for all persons involved in the installation process. If vapor is inhaled, remove to fresh air and administer oxygen if breathing is difficult. Consult a physician immediately.
- » Avoid contact with eyes. Safety glasses or goggles are required.
- » If Flexible FAST adhesive is splashed in eyes, immediately flush eyes with plenty of clean water for at least 15 minutes. Contact a physician immediately.
- » Avoid contact with skin. Wear long-sleeved shirts and long pants. Wash hands thoroughly after handling. In case of contact with skin, thoroughly wash affected area with soap and water or corn oil. NOTE: Permeation-resistant gloves that meet ANSI/ISEA 105-2005 are required when handling the material or during application.
- » Jobsite storage temperatures in excess of 90°F (32°C) may affect product shelf life. When temperatures are in excess of 90°F (32°C) utilize white membrane or material to shield the drums from direct sunlight. Should the components be stored at temperatures lower than 70°F (21°C), restore to room temperature prior to use. Do not

allow Flexible FAST Adhesive to freeze (storage below 0°F (-18°C) for at least 3 days).

- » Use spray booths, windscreens and/or lower spray pressure with spatter tips when spraying.
- » Precautions must be taken to prevent Flexible FAST Adhesive vapors or overspray from entering buildings during application. All air-intake vents on roofs must be closed during application of adhesive.
- » Use desiccant dryers on Part A drums to avoid formation of crystals from exposure to moisture in the air.
- » KEEP OUT OF THE REACH OF CHILDREN.
- » Desiccant dryers should be used to prevent atmospheric moisture contamination of the remaining diisocyanate. Even a small amount of contamination by water or other foreign substance could result in excess pressure and catastrophic failure of the jug container. Do not reseal a jug if contamination is suspected. Move container to a well-ventilated area (outside) and allow to stand for at least 48 hours to allow escape of evolved carbon dioxide to avoid hazardous pressure build-up in container.

Coverage Rates

Application rates may vary depending on ambient temperatures, surface, and substrate absorption rate.

Approximate Coverage Rate (Sq. Ft.)	50 Gallon Drums				
	Full Spray	4" o.c.	6" o.c.	12" o.c.	Splatter Value
	5,000-10,000	6,700-9,000	10,000-12,500	20,000-25,000	18,000-20,000
Approximate Coverage Rate (Sq. Ft.)	15 Gallon Drums				
	Full Spray	4" o.c.	6" o.c.	12" o.c.	Splatter Value
	1,800-3,000	2,110-2,700	3,000-3,750	6,000-7,500	5,400-6,000

LEED® Information

Pre-consumer Recycled Content	0%
Post-consumer Recycled Content	0%
Manufacturing Location	Geismar, LA, Elwood, IL Chattanooga, TN
VOC Content	0 g/L
Solar Reflectance Index	N/A

Flexible FAST Adhesive

Substrate Compatibility

Insulation/Underlayments		Roof Decks		Existing Roofing Materials	
HP Polyiso	Yes	Concrete	Yes	Smooth BUR	Yes ⁵
HP Recovery Board	Yes	Cellular Lt.Wt. Concrete	Yes	Gravel BUR	Yes ⁶
Expanded Polystyrene (EPS)	Yes ¹	NVS Lt.Wt. Concrete	Yes	Mineral Cap Sheet	Yes
Extruded Polystyrene	Yes ²	Gypsum	Yes	Granular Modified-Bitumen	Yes
New Sprayed Foam	Yes	Cementitious Wood Fiber	Yes	Smooth Modified-Bitumen	Yes
Scarified SPF	Yes	Plywood/OSB	Yes	Coal Tar Pitch	Yes ⁷
DensDeck®	Yes	Painted Steel	Yes	Aluminum-Coated BUR	Yes ⁸
SECUROCK®	Yes	Galvanized Steel	Yes ³	Acrylic-Coated SPF	Yes
Oriented Strand Board	Yes	Acoustical Steel	Yes ⁴	Silicone-Coated SPF	Yes ⁹
SecurShield®	Yes	Wood Plank	Yes	Aged EPDM, Hypalon®, TPO	Yes ^{10,12}
				Unweathered Asphalt	Yes/No ¹¹

1. EPS insulation cannot be used directly beneath Sure-Seal® (Black) FleeceBACK membrane unless a light-colored coating is specified. Both Sure-White™ and Sure-Weld® FleeceBACK membranes may be installed directly over minimum 1.5-lb.-density EPS; however, to obtain UL & FM codes, an overlayment of HP Recovery Board, DensDeck, Securock or HP Polyiso insulation is required.
2. For insulation attachment only.
3. For new galvanized steel decks, power-washing is necessary to remove finishing oil residue if present.
4. For acoustical steel decks, fill the flutes with fiberglass or other suitable fill insulation and tack in place with strips of duct tape 3' o.c., or other adhesive, prior to spraying the deck with Flexible FAST Adhesive.
5. Existing Smooth BUR must be Type III or IV asphalt if the (Black) FleeceBACK EPDM, FleeceBACK PVC and KEE HP, or FleeceBACK TPO membrane is to be installed directly without insulation.
6. A minimum ½" HP Recovery Board or insulation is required over properly prepared gravel BUR. FleeceBACK membrane cannot be installed directly over a gravel/slag surface.
7. An insulation providing the necessary R-value must be specified to prevent the coal tar pitch from softening. FleeceBACK membranes cannot be installed directly to coal tar pitch.
8. Any loose coatings must be removed by power-washing or by physical abrasion prior to the application of Flexible FAST Adhesive. A test installation over the aluminum-coated smooth BUR is recommended to ensure the aluminum coating is fully adhered.
9. Silicone-coated substrates must be scarified (coating removed) prior to the application of Flexible FAST Adhesive.
10. Power-washing aged EPDM, Hypalon, or TPO membrane is required prior to the application of Flexible FAST Adhesive.
11. Requires CAV-GRIP III for all applications.
12. Contact Carlisle for specific requirements on TPO recover.

Typical Properties and Characteristics

Base	A-Side Polymeric Isocyanate	B-Side Surfactants and Catalysts
Mixing Ratios by Volume	1:1 Part A to Part B	
Viscosity (CPS @ 25C)	400	400
MDI Content	23%	
Avg. Net Weight	9.88 lbs/gal	9.23 lbs/gal
Packaging	15-gallon drum (57 L) 50-gallon drum (190 L)	15-gallon drum (57 L) 50-gallon drum (190 L)
Shelf Life	1 year	1 year
Temperature Requirements (Substrate & Ambient)		min. 25°F (Heated Equipment) min. 25°F (Unheated Equipment)

Typical R-value added for FleeceBACK membrane attachment: 0.20 to 0.50 R-value. R-value may be higher as more adhesive is used on uneven surfaces.

Physical Property	Test Method	Results
Elongation	ASTM D412	150%
Modulus at 150% Elongation	ASTM D412	20 psi
Dynamic Puncture Resistance - OSB Dynamic Puncture Resistance - HP Recovery Board Dynamic Puncture Resistance - Polyiso	ASTM D5635-04a	33% greater than standard FAST 40% greater than standard FAST 50% greater than standard FAST

Documents





G U I D E - S P E C

Sure-Flex™ PVC KEE HP FleeceBACK® Adhered Roofing System

January 2021

This **GUIDE-SPEC** is a brief outline of Carlisle's Sure-Flex PVC KEE HP FleeceBACK Adhered Roofing System requirements and is intended for use as a submittal with a bid package. Specifiers and the Carlisle Authorized Roofing Applicator must comply with the applicable Sections of Carlisle's Technical Manual, prior to design or bid.

PART I GENERAL

1.01 DESCRIPTION

The Sure-Flex PVC KEE HP FleeceBACK Adhered Roofing System incorporates Sure-Flex KEE HP 50-, 60- or 80-mil thick, 10' wide, polyester reinforced scrim, Sure-Flex PVC KEE HP membrane laminated to a 55-mil thick non-woven polyester fleece-backing resulting in a total finished sheet thickness of 105, 115 or 135-mils. Available in white, gray and tan. The membrane is fully adhered to an acceptable insulation or substrate with a two-component, spray applied, low-rise Flexible FAST Adhesive. Adjoining sheets of membrane are overlapped and joined together with a minimum 1-1/2" wide hot air weld.

1.02 QUALITY ASSURANCE

- A. The specified roofing system must be installed by a Carlisle Authorized Roofing Applicator in compliance with drawings and specifications as approved by Carlisle SynTec.
- B. Upon request, an inspection shall be conducted by a Field Service Representative of Carlisle to ascertain that the membrane roofing system has been installed according to Carlisle's published specifications and details applicable at the time of bid. This inspection is to determine whether a warranty shall be issued. It is not intended as a final inspection for the benefit of the owner.
- C. For specific code approvals achieved with this system, refer to Carlisle's FleeceBACK Code Approval Guide, DORA (Directory of Roof Assemblies), FM Approvals or UL Fire Resistance Directory for Roofing Materials and Systems.

1.03 SUBMITTALS

- A. To ensure compliance with Carlisle's minimum warranty requirements, the following projects should be forwarded to Carlisle for review prior to installation, preferably prior to bid.
 - 1. Air pressurized buildings, canopies, and buildings with large openings, cold storage buildings or freezer facilities, adhered roofing system projects over 100' in height or projects where the FleeceBACK membrane is expected to come in direct contact with petroleum-based products, waste products (i.e., grease, oil, animal fats, etc) and other chemicals.
- B. Shop drawings must be submitted to Carlisle by the Carlisle Authorized Roofing Applicator along with a completely executed Notice of Award (Page 1 of Carlisle's Request For Warranty form) for approval. Approved shop drawings are required for inspection of the roof and on projects where on-site technical assistance is requested.

1.04 GENERAL DESIGN CONSIDERATIONS

- A. It is the responsibility of the building owner or his/her designated representative to verify structural load limitation. In addition, a core cut may be taken to verify weight of existing components when the roofing system is to be specified on an existing facility.
- B. On new construction projects, especially in cold climate regions, moisture generated due to the construction process could adversely impact various components within the roofing assembly if not addressed. [Refer to Spec Supplement G-01-18 "Construction Generated Moisture" included in the Carlisle Technical Manual.]
- C. On structural concrete decks, when a vapor retarder is not used, gaps in the deck along the perimeter and around penetrations must be sealed along with vertical joints between tilt-up panels, if present, to prevent infiltration of hot humid air and possible moisture contamination resulting from condensation. This is specifically important when adhesive is used to attach the roof insulation.



CAUTION: If left unaddressed, collected moisture could weaken insulation boards and facers resulting in a blow-off or increase the probability of mold growth.

D. Vapor Retarders

1. Carlisle does not require a vapor retarder for the protection of the membrane; however, it should be considered by the specifier for the protection of the roofing assembly (i.e. primarily insulation, underlayment and adhesives). The following criteria should be considered by the specifier:
 - a. Use of a vapor retarder to protect insulation and reduce moisture accumulation within an insulated roofing assembly, should be investigated by the specifier.
 - b. In the generally temperate climate of the United States, during the winter months, water vapor flows upward from a heated, more humid interior toward a colder, drier exterior. Vapor retarders are more commonly required in northern climates than in southern regions, where downward vapor pressure may be expected and the roofing membrane itself becomes the vapor retarder.

1.05 WARRANTY

Table I Sure-Flex KEE HP FleeceBACK Adhered Systems Warranty Options

Years	Minimum Membrane Thickness	Warranty Wind Speed			Additional Hail Coverage			
		55 or 72 mph	80 mph	90 or 100 mph	1" Dia. Hail	2" Dia. Hail	3" Dia. Hail	4" Dia. Hail
5,10,15 or 20 year	Sure-Flex KEE HP 105-mil	√	√	√	√	√(1)	N/A	N/A
25 year	Sure-Flex KEE HP 115-mil	√	√	√	√	√	√(1)	N/A
30 year	Sure-Flex KEE HP 135-mil	√	√	√	√	√	√(1)	N/A

Notes: N/A = Not Acceptable √= Acceptable

(1) Requires Flexible FAST in full coverage or beads spaced at 4" o.c.

1.06 PRODUCT DELIVERY, STORAGE AND HANDLING

- A. Deliver materials to the job site in the original, unopened containers labeled with the manufacturer's name, brand name and installation instructions.
- B. Job site storage temperatures in excess of 90°F may affect shelf life of curable materials (i.e., Flexible FAST Adhesive - Parts A & B, sealants, cleaners, primers, and Pourable Sealer).
- C. FleeceBACK Membrane should be stored in its original plastic wrap or be covered to protect from moisture. Any moisture absorbed by the fleece-backing must be removed by using a wet-vac system, prior to membrane adhesion

1.07 JOB CONDITIONS

- A. Refer to Carlisle Technical Manual for applicable project specific Job Conditions.

PART II PRODUCTS

2.01 GENERAL

The components of this roofing system are to be products of Carlisle or accepted by Carlisle as compatible. The installation, performance or

integrity of products by others, **when selected by the specifier and accepted as compatible by Carlisle**, is not the responsibility of Carlisle and is expressly disclaimed by the Carlisle Warranty.

2.02 MEMBRANE

FleeceBACK KEE HP membrane incorporates 50-, 60- or 80-mil thick Polyester Reinforced Elvaloy KEE HP PVC membrane laminated to a 55-mil non-woven fleece backing resulting in a total finished sheet thickness of 105, 115, or 135- mils. Membrane sheets are available in rolls 10' wide by 100' for 105- or 115-mil membranes and 10' wide by 75' long for 135-mil membranes. Sure-Flex KEE HP FleeceBACK Membrane is available in white, gray and tan.

2.03 RELATED MATERIALS

- A. Carlisle Flexible FAST Adhesive, Sure-Flex Non-Reinforced Flashing, Reinforced Cover Strips, Cut-Edge Sealant, PVC and KEE HP Membrane Cleaner, Termination Bars, Insulation Fasteners and Water Cut-Off Mastic. Other Carlisle products such as insulation and edgings are also required when a System Warranty is specified.
- B. **Other Products:** Heat Weldable Walkway Rolls, Pre-Molded Pipe Flashings, Split Pipe Seals, Inside and Outside Corners, Tubing Wraps, LIQUISEAL Liquid Flashing and Molded or Pourable Sealant Pockets.

PART III EXECUTION

3.01 GENERAL

When feasible, begin the application at the highest point of the highest roof level and work to the lowest point to prevent moisture infiltration and minimize construction traffic on completed sections. This will include completion of all flashings and terminations.

3.02 ROOF DECK CRITERIA

- A. A proper substrate shall be provided by the building owner. The structure shall be sufficient to withstand normal construction loads and live loads.
- B. Defects in the roof deck must be reported and documented to the specifier, general contractor and building owner for assessment. The Carlisle Authorized Roofing Applicator shall not proceed unless the defects are corrected.
- C. Refer to Carlisle Technical Manual for acceptable decks and the applicable Carlisle Fasteners (when mechanical attachment of insulation is specified).

3.03 SUBSTRATE REQUIREMENTS

- A. The membrane may be adhered with Flexible FAST Adhesive directly over structural concrete, wood, gypsum and fibrous cement roof decks (new or tear-off). An existing smooth surfaced asphalt built-up roof (Type III or IV Asphalt), modified bitumen or mineral surfaced cap sheet are also acceptable substrates. Direct application over certain types of lightweight insulating concrete substrates may also be specified (contact Carlisle for acceptable lightweight insulating concretes).
- B. Acceptable Carlisle insulations include all types currently approved with Design "A" Adhered Roofing Systems.
- C. The substrate must be dry, relatively smooth, free of protrusions, debris, sharp edges or foreign materials and must be free of accumulated water, ice and snow. Cracks or voids in the substrate greater than 1/4" must be filled with Flexible FAST Adhesive or other suitable material.
- D. On retrofit-recover projects, cut and remove wet insulation as identified by the specifier and fill all voids with new insulation, so that it is relatively flush.

3.04 INSTALLATION

Refer to the applicable Safety Data Sheets and Product Data Sheets for cautions and warnings.

A. Insulation Attachment

1. Carlisle Flexible FAST Adhesive may be specified for insulation securement in full spray or beads with spacing as outlined in the Carlisle Technical Manual.
2. Carlisle Fasteners may be used, when specified, to secure Carlisle Insulation at the specified density outlined in the Carlisle Technical Manual.

B. Membrane Installation

1. FleeceBACK Membrane shall be fully adhered to an acceptable substrate with Carlisle Flexible FAST Adhesive. The adhesive is spray applied to the substrate only and the membrane is rolled into the wet adhesive once it has foamed up approximately 1/8" and begins to string when touched with a HP Splice wipe. Roll the membrane with a 30" wide 150 pound weighted segmented steel roller to set the membrane into the adhesive.
2. Adjoining sheets of FleeceBACK Membrane are overlapped a minimum of 2" along the length of the membrane (at the selvage edge) in preparation for membrane splicing. At end laps (along the width of the sheet), membranes shall be butted together which will be overlaid with a minimum 6" wide Sure-Flex reinforced membrane heat welded on all edges.
3. Refer to Carlisle Technical Manual for alternate attachment methods.
4. **Membrane Splicing – Heat Welding**
 - a. Along the length of the membrane (at selvage edges), heat weld membrane sheets a minimum of 1-1/2" with an Automatic Heat Welder or Hot Air Hand Welder and silicone roller. Refer to Carlisle Technical Manual for specific heat welding procedures.
 - b. Membrane that has been exposed to the elements for approximately 7 days must be prepared by scrubbing the splice area with a scouring pad and Carlisle PVC and KEE HP Membrane Cleaner. Clean all residue from the prepared splice area with a HP Splice Wipe or clean natural fiber (cotton) rag prior to welding.

C. Flashing

1. When feasible, flash all walls/curbs, etc., with continuous deck membrane. When the use of continuous deck membrane is not feasible, a separate piece of Sure-Flex Reinforced Membrane may be utilized (in conjunction with Sure-Flex Bonding Adhesive).
2. Sure-Flex Non-Reinforced Flashing shall be limited to inside/outside corners, field fabricated pipe flashings, scuppers or other unusually shaped walls or penetrations where the use of Sure-Flex FleeceBACK Membrane, Reinforced Sure-Flex Membrane or Prefabricated accessories (pipe flashings, pourable sealer pockets, corners) is not practical.
3. When using the Overlayment Strip (hot air welded) to overlay metal edging flanges, Carlisle PVC and KEE HP Membrane Cleaner is used to clean surfaces as needed.
4. Terminate the flashing in accordance with the appropriate Carlisle Details above anticipated slush line.
5. Copings, counterflashing and metal work, not supplied by Carlisle, shall be fastened to prevent metal from pulling free or buckling and sealed to prevent moisture from entering the roofing system or building.

Copyright 2021 Carlisle Construction Materials Incorporated

Carlisle, Sure-Flex, FleeceBACK, LIQUISEAL and Flexible FAST are Trademarks of Carlisle Construction Materials Incorporated

Carlisle SynTec
P.O. Box 7000, Carlisle, PA 17013-0925
800-479-6832

<http://www.carlisle-syntec.com>

Physical properties of Sure-Flex FleeceBACK Membrane can be referenced in Part II, "Products" of the FleeceBACK Specification. Attach copies of the applicable Carlisle Details that pertain to the individual project to complete a bid package submittal.



Re: Carlisle Sure-Flex PVC Manufacturing

This letter is intended to provide you with confidence in specifying Carlisle Syntec, and assure you of our commitment to providing you and your clients with “best in class” performance when it comes to single-ply roofing. Carlisle is the oldest and most experienced single-ply manufacturer in the United States. We manufacture PVC, EPDM, and TPO membranes, vapor retarders, polyiso insulation, EPS insulation, high density coverboards, and adhesives for both insulation and membrane attachment. No other company has the manufacturing experience of Carlisle, with over 50 years of experience and 18 billion square feet of single-ply membrane manufactured.

Regarding our history in PVC membranes, Carlisle obtained our PVC formulation from HPG in 2003. The Carlisle Sure-Flex membrane’s basic formulation has been successfully used in low-slope roofing applications since 1978.

Our Sure-Flex KEE HP products were developed with the assistance from, and following the formula recommendations of the DuPont Company. The successful track record of the DuPont Elvaloy® based products are well documented and have been in the marketplace for over 45 years.

Carlisle introduced the Sure-Flex PVC line to the market in 2004. We are in our 14th year manufacturing, marketing and selling Sure-Flex, and Carlisle has hundreds of millions of square feet successfully installed and warranted over that period. Carlisle operates 6 extrusion Thermoplastic lines in the United States. Carlisle has more experience and has produced more thermoplastic membrane than any other manufacturer. Please note that Carlisle did not re-label either the Sure-Flex PVC or the Sure-Flex KEE HP. Both product lines were toll manufactured specifically for Carlisle prior to December 2013. As opposed to a private label agreement, Carlisle controlled the specifications, composition, manufacturing parameters and formulation.

We are proud to announce that in December 2013 we opened our newest extrusion manufacturing facility in Greenville, IL. This state of the art PVC manufacturing facility has 10,000 quality control data points, and is far and away the most technologically advanced extrusion process PVC manufacturing line in the industry. Carlisle produces both the PVC and KEE HP membranes on this line.

No other supplier of PVC membranes can provide you with the level of primary manufactured components (membrane, insulation, adhesives) of the roofing



assembly as Carlisle. We also pride ourselves on providing the highest level of technical support, field service, and qualified and trained authorized installers.

Lastly, Carlisle maintains a prudent and conservative approach to warranty reserves. Carlisle Companies Incorporated (the "Company") has recognized liabilities in its Consolidated Balance Sheets for the warranties associated with products produced and sold by Carlisle SynTec (included in the Company's "Construction Materials" business). Total warranty liabilities accrued for the Company's Construction Materials business exceeds \$170 million. This amount is included in the Company's deferred revenue and extended product warranty reserves. The company's quarterly and annual financial statements can be accessed at www.carlisle.com under the investor relation's tab. Specific disclosure product warranty balances can be found at Note 16 Product Warranties (page 104 of Form 10-K).

Based on this information I hope you will choose to include Carlisle Syntec in your master roofing specification.

Please do not hesitate to call or email should you need any additional information on our history or current PVC capabilities.

Respectfully,

A handwritten signature in black ink that reads "John C. Greko". The signature is written in a cursive style with a long horizontal flourish at the end.

John C. Greko
PVC Product Manager
Carlisle Construction Materials
jgreko@carlisleccm.com
Office: 717-245-7325
Mobile: 717-254-9170

Testing & Warranty



GOLDEN SEAL TOTAL ROOFING SYSTEM WARRANTY

SERIAL NO.

Item #4 Sample copy of Warranty.

DATE OF ISSUE:

BUILDING OWNER:**NAME OF BUILDING:****BUILDING ADDRESS:****DATE OF COMPLETION OF THE CARLISLE TOTAL ROOFING SYSTEM:****DATE OF ACCEPTANCE BY CARLISLE:**

Carlisle Roofing Systems, Inc., (Carlisle) warrants to the Building Owner (**Owner**) of the above described building, that; subject to the terms, conditions, and limitations stated in this warranty, Carlisle will repair any leak in the Carlisle Golden Seal™ Total Roofing System (**Carlisle Total Roofing System**) installed by a Carlisle Authorized Roofing applicator for a period of 20 years commencing with the date of Carlisle's acceptance of the Carlisle Total Roofing System installation. However, in no event shall Carlisle's obligations extend beyond 20 years subsequent to the date of substantial completion of the Carlisle Total Roofing System. See below for exact date of warranty expiration.

The Carlisle Total Roofing System is defined as the following Carlisle brand materials: Membrane, Flashings, Counterflashings, Adhesives and Sealants, Insulation, Cover Boards, Fasteners, Fastener Plates, Fastening Bars, Metal Work, Insulation Adhesives, and any other Carlisle brand products utilized in this installation.

TERMS, CONDITIONS, LIMITATIONS

- Owner shall provide Carlisle with written notice via letter, fax or email within thirty (30) days of the discovery of any leak in the Carlisle Total Roofing System. Owner should send written notice of a leak to Carlisle's Warranty Services Department at the address set forth at the bottom of this warranty. By so notifying Carlisle, the Owner authorizes Carlisle or its designee to investigate the cause of the leak. Should the investigation reveal the cause of the leak to be outside the scope of this Warranty, investigation and repair costs for this service shall be paid by the Owner.
- If, upon inspection, Carlisle determines that the leak is caused by a defect in the Carlisle Total Roofing System's materials, or workmanship of the Carlisle Authorized Roofing Applicator in installing the same, Owner's remedies and Carlisle's liability shall be limited to Carlisle's repair of the leak.
- This warranty shall not be applicable if, upon Carlisle's inspection, Carlisle determines that any of the following has occurred:
 - The Carlisle Total Roofing System (Membrane, Insulation or Accessory) is damaged by natural disasters, including, but not limited to, lightning, fire, insect infestations, earthquake, tornado, hail, hurricanes, and winds of (3 second) peak gust speeds of 55mph or higher measured at 10 meters above ground; or
 - Loss of integrity of the building envelope and, or structure including, but not limited to partial or complete loss of roof decking, wall siding, windows, doors or other envelope components or from roof damage by wind-blown objects, or;
 - The Carlisle Total Roofing System is damaged by any intentional or negligent acts, accidents, misuse, abuse, vandalism, civil disobedience, or the like.
 - Deterioration or failure of building components, including, but not limited to, the roof substrate, walls, mortar, HVAC units, non-Carlisle brand metal work, etc., occurs and causes a leak, or otherwise damages the Carlisle Total Roofing System; or
 - Acids, oils, harmful chemicals and the like come in contact with the Carlisle Total Roofing System and cause a leak, or otherwise damage the Carlisle Total Roofing System.
 - The Carlisle Total Roofing System encounters leaks or is otherwise damaged by condensation resulting from any condition within the building that may generate moisture.
- This Warranty shall be null and void if any of the following shall occur:
 - If, after installation of the Carlisle Total Roofing System by a Carlisle Authorized Roofing Applicator there are any alterations or repairs made on or through the roof or objects such as, but not limited to, structures, fixtures, solar panels, wind turbines, roof gardens or utilities are placed upon or attached to the roof without first obtaining written authorization from Carlisle; or
 - Failure by the Owner to use reasonable care in maintaining the roof, said maintenance to include, but not be limited to, those items listed on Carlisle's Care & Maintenance Information sheet which accompanies this Warranty.
- Only Carlisle brand insulation products are covered by this warranty. Carlisle specifically disclaims liability, under any theory of law, for damages sustained by or caused by non-Carlisle brand insulation products.
- During the term of this Warranty, Carlisle shall have free access to the roof during regular business hours.
- Carlisle shall have no obligation under this Warranty while any bills for installation, supplies, service, and warranty charges have not been paid in full to the Carlisle Authorized Roofing Applicator, Carlisle, or material suppliers.
- Carlisle's failure at any time to enforce any of the terms or conditions stated herein shall not be construed to be a waiver of such provision.
- Carlisle shall not be responsible for the cleanliness or discoloration of the Carlisle Total Roofing System caused by environmental conditions including, but not limited to, dirt, pollutants, or biological agents.
- Carlisle shall have no liability under any theory of law for any claims, repairs, restoration, or other damages including, but not limited to, consequential or incidental damages relating, directly or indirectly, to the presence of any irritants, contaminants, vapors, fumes, molds, fungi, bacteria, spores, mycotoxins, or the like in the building or in the air, land, or water serving the building.
- This warranty is not assignable by operation of law or otherwise. Application may be made by a new building owner for reissuance of the warranty during the original warranty period. Certain procedures including, but not limited to, an inspection of the Roofing System by a Carlisle representative and fees will apply to any reissuance. Should these procedures be satisfied, Carlisle will not unreasonably withhold the reissuance of this warranty.

CARLISLE DOES NOT WARRANT PRODUCTS UTILIZED IN THIS INSTALLATION WHICH IT HAS NOT FURNISHED; AND SPECIFICALLY DISCLAIMS LIABILITY, UNDER ANY THEORY OF LAW, ARISING OUT OF THE INSTALLATION AND PERFORMANCE OF, OR DAMAGES SUSTAINED BY OR CAUSED BY, PRODUCTS NOT FURNISHED BY CARLISLE OR THE PRIOR EXISTING ROOFING MATERIAL OVER WHICH THE CARLISLE ROOFING SYSTEM HAS BEEN INSTALLED

THE REMEDIES STATED HEREIN ARE THE SOLE AND EXCLUSIVE REMEDIES FOR FAILURE OF THE CARLISLE TOTAL ROOFING SYSTEM OR ITS COMPONENTS. THERE ARE NO WARRANTIES EITHER EXPRESSED OR IMPLIED, INCLUDING THE IMPLIED WARRANTIES OF FITNESS FOR A PARTICULAR PURPOSE AND MERCHANTABILITY, WHICH EXTEND BEYOND THE FACE HEREOF. CARLISLE SHALL NOT BE LIABLE FOR ANY INCIDENTAL, CONSEQUENTIAL OR OTHER DAMAGES INCLUDING, BUT NOT LIMITED TO, LOSS OF PROFITS OR DAMAGE TO THE BUILDING OR ITS CONTENTS UNDER ANY THEORY OF LAW.

BY: Robert H. McNeill

AUTHORIZED SIGNATURE

TITLE: Director, Technical and Warranty Services

This Warranty Expires:

DIVISION: 07 00 00—THERMAL AND MOISTURE PROTECTION
Section: 07 53 23—Ethylene-Propylene-Diene-Monomer Roofing
Section: 07 54 19—Polyvinyl-Chloride Roofing
Section: 07 54 23—Thermoplastic-Polyolefin Roofing

REPORT HOLDER:

CARLISLE SYNTEC SYSTEMS, A DIVISION OF CARLISLE CONSTRUCTION MATERIALS, LLC

EVALUATION SUBJECT:

CARLISLE EPDM, PVC AND TPO SINGLE-PLY ROOFING MEMBRANES

ADDITIONAL LISTEES:

- KELLY COMPANY/2001 INC.**
- MULE-HIDE PRODUCTS COMPANY, INC.**
- VERSICO**
- WEATHERBOND**
- ROOFING PRODUCTS INTERNATIONAL, INC.**

1.0 EVALUATION SCOPE

Compliance with the following codes:

- 2018, 2015, 2012 and 2009 *International Building Code*® (IBC)
- 2018, 2015, 2012 and 2009 *International Residential Code*® (IRC)
- 2013 *Abu Dhabi International Building Code* (ADIBC)†

†The ADIBC is based on the 2009 IBC. 2009 IBC code sections referenced in this report are the same sections in the ADIBC.

For evaluation for compliance with codes adopted by the Los Angeles Department of Building and Safety (LADBS), see [ESR-1463 LABC and LARC Supplement](#).

Properties evaluated:

- Weather resistance
- Roof covering fire classification
- Wind uplift resistance
- Impact resistance

2.0 USES

Carlisle ethylene propylene diene monomer (EPDM), polyvinyl chloride (PVC) and thermoplastic polyolefin (TPO) single-ply roofing membranes are used as roof coverings in adhered and mechanically fastened membrane roofing systems.

3.0 DESCRIPTION

3.1 General:

The EPDM, PVC and TPO Membrane Roofing Systems described in this report consist of single-ply roofing membranes, insulation where used, barrier board or slip sheet where used, flashing, mechanical fasteners and adhesives that are installed on a combustible or noncombustible deck. See Table 1 for Carlisle product trade names and corresponding product names for Mule-Hide Products Company, Inc., WeatherBond, Versico, Kelly Company/2001 Inc., and Roofing Products International, Inc., the additional listees.

3.2 EPDM Membranes:

3.2.1 Sure-Seal: Sure-Seal is a black, nonreinforced EPDM membrane, 45 mils thick [0.045 inch (1.14 mm)].

3.2.2 Sure-Seal FR: Sure-Seal FR is a black, nonreinforced EPDM membrane with fire retardants. Available thicknesses range from 45 mils (0.045 inch [1.14 mm]) to 90 mils (0.090 inch [2.29 mm]).

3.2.3 Sure-White: Sure-White is a white, nonreinforced EPDM membrane. It is available in thicknesses of 60 mils [0.060 inch (1.52 mm)] and 90 mils [0.090 inch (2.29 mm)].

3.2.4 Sure-Tough: Sure-Tough is a black, reinforced membrane consisting of a polyester reinforcement encapsulated between two EPDM membrane plies. It is available in thicknesses ranging from 45 mils [0.045 inch (1.14 mm)] to 75 mils [0.075 inch (1.90 mm)].

3.2.5 Sure-Tough FR: Sure-Tough FR is a black, reinforced membrane consisting of a polyester reinforcement encapsulated between two EPDM membrane plies with fire retardants. Available thicknesses are 45 mils [0.045 inch (1.14 mm)] and 60 mils [0.060 inch (1.52 mm)].

3.2.6 Sure-Seal FleeceBACK: Sure-Seal FleeceBACK is a 45-mil to 90-mil [0.045 inch to 0.090 inch (1.14 mm to 2.29 mm)] non-reinforced EPDM bonded to a polyester fleece. Available product thicknesses range from 100 mils [0.100 inch (2.55 mm)] to 145 mils [0.145 inch (3.68 mm)].

3.2.7 Sure-White FleeceBACK: Sure-White FleeceBACK is a 45-, 60- or 90-mil [0.045, 0.060 or 0.090 inch

(1.14, 1.52 or 2.29 mm)] nonreinforced white EPDM bonded to a polyester fleece. Available product thicknesses are 100, 115 and 145 mils [0.100, 0.115 or 0.145 inch (2.54, 2.92 or 3.68 mm)].

3.2.8 Sure-Seal AFX: Sure-Seal AFX is a 45-mil [0.045 inch (1.14 mm) or 60-mil [0.060 inch (1.52 mm)] non-reinforced EPDM bonded to a 7 polyester fleece. Available thicknesses are 90 mils [0.090 inch (2.29 mm)] and 105 mils [0.105 inch (2.67 mm)].

3.3 PVC Membranes:

3.3.1 Sure-Flex PVC: Sure-Flex PVC is a heat-weldable PVC thermoplastic membrane consisting of a weft-inserted polyester fabric that is encapsulated by PVC based top and bottom plies. Available thicknesses range from 50 mils [0.050 inch (1.27 mm)] to 80 mils [0.080 inch (2.03 mm)].

3.3.2 Sure-Flex KEE HP: Sure-Flex KEE HP is a heat-weldable thermoplastic membrane that consists of a polyester fabric that is encapsulated by KEE HP based top and bottom plies. Available thicknesses range from 50 mils [0.50 inch (1.27 mm)] to 80 mils [0.80 inch (2.03 mm)].

3.3.3 Sure-Flex PVC FRS: Sure-Flex PVC FRS is a heat-weldable thermoplastic membrane that consists of a fiberglass reinforcement encapsulated with PVC based top and bottom plies. Available thicknesses range from 60 mils [0.60 inch (1.52 mm)] to 80 mils [0.80 inch (2.03 mm)].

3.3.4 Sure-Flex PVC FleeceBACK: Sure-Flex PVC FleeceBACK membrane consists of polyester reinforcing scrim and polyester fleece backing. Available thicknesses range from 115 mils [0.115 inch (2.92 mm)] to 135 mils [0.135 inch (3.43 mm)].

3.3.5 Sure-Flex KEE HP FleeceBACK: Sure-Flex KEE HP FleeceBACK membrane consists of a polyester reinforcing scrim, polyester fleece backing, and DuPont® Elvaloy® KEE HP copolymer. Available thicknesses range from 105 mils [0.105 inch (2.67 mm)] to 135 mils [0.135 inch (3.43 mm)].

3.3.6 Sure-Flex PVC FRS FleeceBACK: Sure-Flex PVC FRS FleeceBACK membrane consists of a high-strength fiberglass scrim and polyester fleece backing. Available thicknesses range from 115 mils [0.115 inch (2.92 mm)] to 135 mils [0.135 inch (3.43 mm)].

3.3.7 Sure-Flex KEE HP FRS FleeceBACK: Sure-Flex KEE HP FRS FleeceBACK membrane consists of a fiberglass reinforcing scrim, polyester fleece backing, and DuPont® Elvaloy® KEE HP copolymer. Available thicknesses range from 105 mils [0.105 inch (2.67 mm)] to 135 mils [0.135 inch (3.43 mm)].

3.4 TPO Membranes:

3.4.1 Sure-Weld: Sure-Weld membrane consists of a polyester reinforcement encapsulated between two plies of TPO. The membrane is available in white, gray, tan and custom colors. Available thicknesses range from 45 mils [0.045 inch (1.14 mm)] to 80 mils [0.080 inch (2.03 mm)].

3.4.2 Sure-Weld HS: Sure-Weld HS is the Sure-Weld membrane formulated with an additional flame retardant for fire resistance at higher slopes. The membrane is available in white, gray, tan and custom colors. Available thicknesses are 45 mils (0.045 inch [1.14 mm]) and 60 mils (0.060 inch [1.52 mm]).

3.4.3 Sure-Weld SAT-TPO: Sure-Weld SAT-TPO is a self-adhered version of the Sure-Weld HS membrane with adhesive.

3.4.4 Sure-Weld FleeceBACK: Sure-Weld FleeceBACK is the Sure-Weld HS membrane, 45 mils [0.045 inch

(1.14 mm)], 60 mils [0.60 inch (1.52 mm)] and 80 mils [0.60 inch (2.03 mm)] thick, with a laminated polyester fleece backing. Available thicknesses are 100 mils [0.100 inch (2.54 mm)], 115 mils [0.115 inch (2.92 mm)] and 135 mils [0.135 inch (3.43 mm)].

3.4.5 Sure-Weld AFX: Sure-Weld AFX is the Sure-Weld HS membrane with a laminated polyester fleece backing. Available thicknesses range from 120 mils [0.120 inch (3.05 mm)] to 155 mils [0.155 inch (3.94 mm)].

3.4.6 Spectro-Weld: Spectro-Weld is the Sure-Weld membrane, described in Section 3.4.1, formulated with a brighter white color. Available thicknesses are 60 mils [0.060 inch (1.52 mm)] and 80 mils [0.080 inch (2.03 mm)].

3.4.7 Spectro-Weld FleeceBACK: Spectro-Weld FleeceBACK is the Spectro-Weld membrane with a laminated 5.5-ounce-per-square-yard (0.18 kg/m²) polyester fleece backing. It is 115 mils [0.115 inch (2.92 mm)] thick.

3.5 Insulation:

See Tables 2 through 5 for insulations for use with specific roofing systems. Foam plastic insulation, where used, must have a flame-spread index of not more than 75 when tested at the maximum thickness intended for use in accordance with ASTM E84 or UL 723.

3.6 Barrier Board:

Barrier board, where used, must be either minimum 1/4-inch-thick (6.4 mm) Georgia-Pacific Gypsum LLC “DensDeck® Roofboard” or “DensDeck Prime® Roofboard,” minimum 1/4-inch-thick (6.4 mm) Owens Corning “StrataGuard,” minimum 1/4-inch-thick (6.4 mm) USG Corporation “SECUROCK® Gypsum-Fiber Roof Board” or “SECUROCK® Glass-Mat Roof Board,” or minimum 1/2-inch-thick (12.7 mm) gypsum board. Barrier board must be UL-classified for roofing applications or UL-classified gypsum board.

3.7 Slip Sheet:

The slip sheet, where used, must include Carlisle “FR Base Sheet 1S or 2S,” GAF “VersaShield® Fire-Resistant Roof Deck Protection ([ESR-2053](#)),” Elk “VersaShield FB-1S or FB-2S,” or Atlas “FR 10 or FR 50.” Slip sheets must be UL-classified for roofing applications.

3.8 Flashing:

Flashing must be provided in accordance with IBC Section 1503.2 or IRC Section R903.2, as applicable. Where flashing is of metal, the metal must be corrosion-resistant, minimum No. 26 gage [0.019 inch (0.483 mm)] galvanized steel.

3.9 Fasteners:

Fasteners, used to mechanically attach insulation and membranes to the roof deck, must be corrosion-resistant, and must be Carlisle fasteners, plates or fastening bars, unless otherwise noted in this report. Refer to Table 4 and 5 for spacing of fasteners.

3.9.1 HP Fastener: This is an epoxy-coated steel screw used in combination with Carlisle’s fastening plates or bars to mechanically attach roofing insulation and membranes to steel or wood substrate. Fastener length must be selected to penetrate through the steel deck a minimum of 3/4 inch (19.1 mm), and into the wood deck a minimum of 1 inch (25.4 mm).

3.9.2 InsulFast Insulation Fastener: This is an epoxy-coated steel screw used in combination with Carlisle’s insulation plates to mechanically attach roofing insulation to steel or wood substrates. Fastener length must be selected to penetrate through the steel deck a minimum of 3/4 inch

(19.1 mm), or into the wood deck a minimum of 1 inch (25.4 mm).

3.9.3 HP Purlin Fastener: This is an epoxy-coated steel screw used in combination with Carlisle's fastening plates or bars to mechanically attach roofing insulation and membranes to structural steel members. Fastener length must be selected to penetrate through the steel member a minimum of $\frac{3}{4}$ inch (19.1 mm).

3.9.4 HD 14-10 Fastener: This is a heavy-duty, epoxy-coated steel screw used in combination with Carlisle's fastening plates or bars to mechanically attach roofing insulation and membranes to concrete roof deck. Fastener length must be selected to penetrate into the concrete deck a minimum of 1 inch (25.4 mm).

3.9.5 CD-10 Fastener: The CD-10 is an epoxy-coated, hammer-driven, nonthreaded fastener specifically designed to be used with insulation and seam fastening plates to secure membrane and insulation to structural concrete. Fastener length must be selected to penetrate into the concrete deck a minimum of 1 inch (25.4 mm).

3.9.6 Lite-Deck Fastener: The Lite-Deck Fastener is used in conjunction with a specially designed 3-inch (76.2 mm) Lite-Deck Metal Plate for insulation attachment to gypsum, cementitious wood fiber (Tectum [\[ESR-1112\]](#)), and lightweight concrete decks. Fastener length must be selected to penetrate into the deck a minimum of 2 inches (50.8 mm).

3.9.7 GypTec Fastener: The GypTec Fastener is a glass-filled nylon auger fastener designed for securing mechanically attached membranes and insulation to gypsum and cementitious wood fiber (Tectum [\[ESR-1112\]](#)) decks. Fastener length must be selected to penetrate into the deck a minimum of 1.5 inches (38.1 mm).

3.9.8 HP Polymer Seam Plate: This is a 2-inch-diameter (50 mm) polymer plate designed to be used with HP and HD 14-10 fasteners to mechanically attach roofing membranes to the roof deck.

3.9.9 Sure-Tite Fastener and ST Fastening Bar: This is a heavy-duty, epoxy-coated steel screw and bar used to secure reinforced EPDM membranes to steel or wood deck. The bar is 1-inch-wide-by-0.040-inch-thick-by-10-foot-long (25.4 mm by 1.1 mm by 3.1 m) galvalume-coated steel with pre-punched holes 6 inches (150 mm) on center.

3.9.10 HP-X Fastener: This is an epoxy-coated carbon steel screw used in combination with the Piranha Fastening Plate to mechanically attach TPO membranes to steel or wood substrate. Fastener length must be selected to penetrate through the steel deck a minimum of $\frac{3}{4}$ inch (19.1 mm), and into the wood deck a minimum of 1 inch (25.4 mm).

3.9.11 Piranha Fastening Plate: This is a $2\frac{3}{8}$ -inch-diameter galvalume-coated steel plate designed to be used with HP-X fasteners to mechanically attach PVC and TPO membranes to the roof deck.

3.9.12 HP-XTRA Fastener: This is an epoxy-coated carbon steel screw used in combination with the Piranha XTRA Fastening Plate to mechanically attach PVC and TPO membranes to steel or wood substrate. Fastener length must be selected to penetrate through the steel deck a minimum of $\frac{3}{4}$ inch (19.1 mm) and into the wood deck a minimum of 1 inch (25.4 mm).

3.9.13 Piranha XTRA Fastening Plate: This is a $2\frac{3}{8}$ -inch-diameter galvalume-coated steel plate designed to be used with HP-XTRA fasteners to mechanically attach PVC and TPO membranes to the roof deck.

3.9.14 PVC Oval Barbed Plate: This is a $1\frac{1}{2}$ -inch-by- $2\frac{3}{4}$ -inch (35 mm by 69.85 mm) Oval Barbed Plate designed to be used with HP-X Fasteners to mechanically attach PVC membranes to the roof deck.

3.9.15 OMG Roofing Products RhinoBond Plate: The RhinoBond Plate is a 3-inch-diameter (76.2 mm), 0.028-inch-thick (0.7 mm) galvalume-coated steel plate, coated with a proprietary adhesive and used with the HP-X fastener to mechanically attach PVC and TPO membranes to the roof deck. The adhesive bonds the plate to the underside of the membrane.

3.10 Carlisle Syntec Adhesives: See Tables 2 and 5 for adhered roofing systems.

3.10.1 90-8-30A Bonding Adhesive: 90-8-30A Bonding Adhesive is a high-strength, solvent-based contact adhesive used to adhere EPDM membranes to the insulation or substrate. It has a coverage rate of approximately 60 square feet per gallon (1.5 m²/L) when applied to the finished surface area. The adhesive is supplied in 5-gallon (18.9 L) containers and has a shelf life of one year.

3.10.2 Aqua Base 120 Bonding Adhesive: Aqua Base 120 Bonding Adhesive is a high-strength, water-based contact adhesive used to adhere EPDM and TPO membranes to the insulation or substrate. It has a coverage rate of approximately 120 square feet per gallon (3 m²/L) when applied to the finished surface area. The adhesive is supplied in 5-gallon (18.9 L) containers and has a shelf life of one year.

3.10.3 Low-VOC PVC Bonding Adhesives: Low VOC PVC Bonding Adhesives is high-strength, solvent-based contact adhesives used to adhere PVC membranes to an insulation or substrate. They have a coverage rate of approximately 60 square feet per gallon (1.5 m²/L) when applied to the finished surface area. The adhesive is supplied in 5-gallon (18.9 L) containers with a shelf life of one year.

3.10.4 Sure-Weld TPO Bonding Adhesive: Sure-Weld TPO Bonding Adhesive is a high-strength, solvent-based contact adhesive used to adhere TPO membranes to an insulation or substrate. It has a coverage rate of approximately 60 square feet per gallon (1.5 m²/L) when applied to the finished surface area. The adhesive is supplied in 5-gallon (18.9 L) containers with a shelf life of one year.

3.10.5 Low VOC Bonding Adhesive: Low VOC Bonding Adhesive is a high-strength, solvent-based contact adhesive used to adhere EPDM and TPO membranes to an insulation or substrate. It has a coverage rate of approximately 60 square feet per gallon (1.5 m²/L) when applied to the finished surface area. The adhesive is supplied in 5-gallon (18.9 L) containers with a shelf life of one year.

3.10.6 HydroBond Water-Based Bonding Adhesive: HydroBond Water-Based Bonding Adhesive is a water-based, wet lay-in, one-sided adhesive to be used to adhere Sure-Flex PVC, Sure-Flex PVC FRS and FleeceBACK membranes to an insulation or substrate. It has a coverage rate of 100 square feet per gallon (2.5 m²/L). The adhesive is supplied in 5-gallon (18.9 L) containers with a shelf life of one year.

3.10.7 Low VOC Bonding Adhesive 1168: Low VOC Bonding Adhesive 1168 is high-strength, solvent-based contact adhesive used to adhere EPDM and TPO membranes to an insulation or substrate. It has a coverage rate of approximately 60 square feet per gallon (1.58 m²/L) when applied to the finished surface area. The adhesive is

supplied in 5-gallon (18.9 L) containers with a shelf life of one year.

3.10.8 Solvent-Free EPDM Bonding Adhesive: Solvent-Free EPDM Bonding Adhesive is a high-strength, polymer-based adhesive. This adhesive can be used to adhere all Sure-Seal or Sure-White EPDM membranes as a one-sided, wet lay-in adhesive. It has a coverage rate of 100 square feet per gallon (2.5 m²/L). The adhesive is supplied in 5-gallon (18.9 L) containers with a shelf life of six months.

3.10.9 Cold Applied Adhesive: Cold Applied Adhesive is a solvent-free, asphalt-modified polyether adhesive. This adhesive can be used with all Sure-Seal or Sure-Weld AFX membranes as a one-sided, wet lay-in adhesive. It has a coverage rate of 67 square feet per gallon (1.6 m²/L). The adhesive is supplied in 5-gallon (18.9 L) containers with a shelf life of one year.

3.10.10 FAST Adhesives: FAST 100, FAST 100LV, and Flexible FAST Adhesives are two-component polyurethane adhesives used to adhere FleeceBACK membranes and insulations to various substrates. The adhesives have a coverage rate of approximately 100 square feet per gallon (2.5 m²/L). The adhesives are supplied in 5-gallon (18.9 L) jugs, 15-gallon (56.7 L) and 50-gallon (189 L) drums, box sets, cartridge tubes, dual tanks, and/or cylinders, and have a shelf life of one year.

3.10.11 OlyBond 500 Adhesive: OMG Roofing Products OlyBond 500 Spot Shot and OlyBond 500 BA are two-component polyurethane adhesives used to adhere insulations to various substrates. The adhesives have a coverage rate of approximately 100 square feet per gallon (2.5 m²/L). The adhesives are supplied in cartridge tubes and box sets, and have a shelf life of one year.

3.10.12 EPDM X-23 Low-VOC Bonding Adhesive: EPDM X-23 Low-VOC Bonding Adhesive is a high strength, solvent-based contact adhesive used to adhere EPDM membranes to an insulation or substrate. It has a coverage rate of approximately 60 square feet per gallon (1.5 m²/L) when applied to the finished surface area. The adhesive is supplied in 5-gallon (18.9 L) containers with a shelf life of one year.

3.10.13 CAV-GRIP III Low-VOC Adhesive/Primer: CAV-GRIP III Low-VOC Adhesive/Primer is a contact adhesive used to adhere EPDM and TPO membranes to various substrates. It has a coverage rate of 1000 ft² per cylinder when applied to the finished surface area. The adhesive is supplied in No. 40 cylinders with a shelf life of one year (unopened).

3.11 Impact Resistance:

The EPDM, PVC, and TPO roofing membranes described in this report meet requirements for impact resistance in IBC Section 1504.7, based on testing in accordance with Section 4.6 of FM 4470.

4.0 INSTALLATION

4.1 General:

Installation of the EPDM, PVC, and TPO roofing membranes described in this report must comply with the applicable code, the manufacturer's published installation instructions and this report. The manufacturer's published installation instructions must be available at all times on the jobsite during installation.

The substrate to which the membrane is to be applied must be clean, dry, and free of frost, loose fasteners, and other protrusions or contaminants that will interfere with the adhesion or attachment of the membrane or that will puncture the membrane. All materials must be protected

against contact with incompatible materials. Where gypsum board is used as barrier board in the roofing assembly, weather protection must be provided to prevent damage to the gypsum board prior to application of the roofing membrane.

The slope of the roof on which the single-ply membranes are installed must not be more than the maximum slope indicated for the particular assembly as listed in Tables 2 and 3.

Penetrations and terminations of the roof covering must be flashed and made weather tight in accordance with the requirements of the membrane manufacturer and the applicable code.

4.2 Fire Classification:

4.2.1 New Construction: The adhered and mechanically fastened EPDM, PVC, and TPO single-ply membrane roofing systems, when installed in accordance with this report, are Class A, B or C roof covering systems in accordance with ASTM E108 or UL 790, as noted in Tables 2 and 3.

4.2.2 Reroofing: The existing deck must be inspected to verify that the structure to be reroofed is structurally sound and adequate to support and secure the roofing membrane. Prior to installation of new roof coverings, inspection by and written approval from the code official having jurisdiction must be required.

Class A, B or C roof covering systems may be installed over existing classified roof covering systems under the following conditions without additional roof classification tests, provided the resulting classification is the lower of the new or existing roofing classification:

- New uninsulated systems installed only over existing uninsulated assemblies.
- New insulated systems installed over existing uninsulated systems only.

4.3 Wind Resistance:

4.3.1 New Construction: The allowable wind uplift pressures for the EPDM, PVC, and TPO roofing membranes as parts of roof assemblies are noted in Tables 4 and 5.

Metal edge securement systems must be listed in accordance with the 2011 edition of ANSI/SPRI/FM4435 ES-1 and designed and installed for wind loads in accordance with IBC Section 1504.5 and IBC Chapter 16.

4.3.2 Reroofing: Mechanically anchored systems may be accepted based on the adequacy of anchors penetrating through existing roof coverings into structural substrates. Since the composition and/or condition of any particular existing underlying material may vary widely, reroofing with adhered systems is outside the scope of this report.

5.0 CONDITIONS OF USE

The single-ply EPDM, PVC, and TPO roofing membranes described in this report comply with, or are suitable alternatives to what is specified in, those codes listed in Section 1.0 of this report, subject to the following conditions:

- 5.1** Installation must comply with the applicable code, the manufacturer's published installation instructions and this report. The instructions within this report must govern if there are any conflicts between the manufacturer's installation instructions and this report.
- 5.2** The adhered and mechanically fastened single-ply membrane roofing systems must be installed by professional roofing contractors who are trained and approved by the manufacturer.

- 5.3 Foam plastic insulation must be separated from the interior of the building by an approved thermal barrier in accordance with IBC Section 2603.4.1.5 or IRC Section R316.4, as applicable.
- 5.4 Foam plastic insulation, where used, must bear the label of an approved agency indicating that the foam plastic has a flame-spread index of not more than 75 when tested at the maximum thickness intended for use in accordance with ASTM E84 or UL 723, subject to the approval of the code official.
- 5.5 Design wind uplift pressure on any roof area, including edge and corner zones, must not exceed the allowable wind uplift pressure for the system installed in that particular area. Refer to allowable wind uplift pressures for systems as listed in Tables 4 and 5.
- 5.6 The allowable wind uplift pressures listed in Tables 4 and 5 are for the roof covering system only. The deck and framing to which the system is attached must be designed for the applicable components and cladding wind loads in accordance with the applicable code.
- 5.7 When application is over existing roofs, documentation of the wind-uplift resistance of the composite roof construction must be submitted to the code official for approval at the time of permit application.
- 5.8 For buildings under the IBC, above deck thermal insulation board must comply with the applicable standards listed in IBC Table 1508.2 or IRC Table R906.2, as applicable.
- 5.9 The roofing membranes are manufactured at Carlisle, Pennsylvania; Greenville, Illinois; Tooele, Utah; and Senatobia, Mississippi, under a quality control program with inspections by ICC-ES.

6.0 EVIDENCE SUBMITTED

Data in accordance with ICC-ES Acceptance Criteria for Membrane Roof-covering Systems (AC75), dated July 2010 (editorially revised March 2018).

7.0 IDENTIFICATION

- 7.1 Each roll of the roofing membrane must bear a label noting the product name, the manufacturer's name (Carlisle SynTec Systems) or the name of the

additional listee, the manufacturer's address or plant code and the ICC-ES evaluation report number (ESR-1463).

- 7.2 The report holder's contact information is the following:

**CARLISLE SYNTEC SYSTEMS, A DIVISION OF
CARLISLE CONSTRUCTION MATERIALS
POST OFFICE BOX 7000
CARLISLE, PENNSYLVANIA 17013
(717) 245-7000
www.carlisesyntec.com**

- 7.3 The Additional Listees' contact information is the following:

**KELLY COMPANY/2001 INC.
325 THOMASTON AVENUE
WATERBURY, CONNECTICUT 06702
(203) 575-9220**

**MULE-HIDE PRODUCTS COMPANY, INC.
1195 PRINCE HALL DRIVE
BELOIT, WISCONSIN 53511
(800) 786-1492**

**VERSICO
POST OFFICE BOX 1289
CARLISLE, PA 17013
(800) 992-7663**

**WEATHERBOND
POST OFFICE BOX 251
PLAINFIELD, PENNSYLVANIA 17081
(866) 471-5125**

**ROOFING PRODUCTS INTERNATIONAL, INC.
57460 DEWITT STREET
ELKHART, INDIANA 46517
(800) 628-2957**

TABLE 1—PRODUCT NAMES

CARLISLE PRODUCT NAME	KELLY CO./ 2001 INC. PRODUCT NAME	MULE-HIDE PRODUCT NAME	VERSICO PRODUCT NAME	WEATHERBOND PRODUCT NAME	ROOFING PRODUCTS INTERNATIONAL PRODUCT NAME
Sure-Seal	C-EPDM	Mule-Hide Standard Black EPDM	VersiGard Non-reinforced EPDM	WeatherBond EPDM Non-Reinforced Membrane	Royal Edge Non-Reinforced EPDM
Sure-Seal FR	C-EPDM-C	Mule-Hide FR EPDM	VersiGard FR Non-Reinforced EPDM	WeatherBond EPDM FR Non-Reinforced Membrane	Royal Edge Non-Reinforced FR EPDM
Sure-Seal FleeceBACK	C-EPDM-FB	-	VersiFleece EPDM	WeatherBond Fleece EPDM Membrane	Royal Edge EPDM FleeceBACK
Sure-Seal AFX	C-EPDM-AFX	-	VersiFleece AC EPDM	WeatherBond EPDM AC Fleece Membrane	-
Sure-Tough	C-EPDM-C, Type 2	Mule-Hide Standard Reinforced EPDM	VersiGard Reinforced EPDM	WeatherBond EPDM Reinforced Membrane	Royal Edge Reinforced EPDM
Sure-Tough FR	C-EPDM-CR Reinforced	Mule-Hide FR Reinforced EPDM	VersiGardFR Reinforced EPDM	WeatherBond EPDM FR Reinforced Membrane	Royal Edge Reinforced Fire Rated EPDM
Sure-White	C-EPDM-White	Mule-Hide White-on-Black EPDM	VersiGard –White Standard	WeatherBond EPDM White Membrane	Re-Flex White EPDM
Sure-White FleeceBACK	C-EPDM-FB-White	-	-	-	Re-Flex White EPDM FleeceBACK
Sure-Weld	TPO-K	Mule-Hide TPO-c	VersiWeld Reinforced TPO Membrane	WeatherBond TPO Membrane	Re-Flex TPO
Sure-Weld HS	TPO-K-FR	Mule-Hide TPO-c (FR)	VersiWeld HS	WeatherBond TPO High Slope Membrane	Re-Flex TPO HS
Sure-Weld SAT-TPO	TPO-K_SAT	Mule-Hide SA-TPO	VersiWeld QA TPO Membrane	WeatherBond TPO PAS Membrane	Re-Flex TPO SAT
Sure-Weld FleeceBACK	TPO-K-FB	Mule-Hide TPO-c Fleece Back	VersiFleece TPO	WeatherBond FleeceTPO Membrane	Re-Flex TPO FleeceBACK
Sure-Weld AFX	TPO-K-AFX	Mule-Hide TPO-c Fleece Back Plus	VersiFleece AC TPO	WeatherBond TPO AC Fleece Membrane	-
Spectro-Weld	-	-	-	-	-
Spectro-Weld FleeceBACK	-	-	-	-	-
Sure-Flex PVC	-	Mule-Hide PVC Membrane	VersiFlex PVC	WeatherBond PVC Membrane	Re-Flex PVC
Sure-Flex KEE HP	-	Mule-Hide PVC KEE HP Membrane	VersiFlex KEE HP	WeatherBond KEE HP Membrane	Re-Flex KEE HP
Sure-Flex PVC FRS	-	Mule-Hide PVC FRS Membrane	VersiFlex FRS PVC	WeatherBond PVC FRS Membrane	Re-Flex FRS PVC
Sure-Flex PVC FleeceBACK	-	Mule-Hide PVC FleeceBack Membrane	VersiFleece PVC	WeatherBond PVC Fleece Membrane	-
Sure-Flex KEE HP FleeceBACK	-	Mule-Hide PVC KEE HP Fleece Back Membrane	VersiFleece KEE HP	WeatherBond KEE HP Fleece Membrane	-
Sure-Flex PVC FRS FleeceBACK	-	-	VersiFleece FRS PVC	WeatherBond PVC FRS Fleece Membrane	Re-Flex FRS PVC FleeceBACK
Sure-Flex KEE HP FRS FleeceBACK	-	-	VersiFleece FRS KEE HP	WeatherBond KEE HP FRS Fleece Membrane	-
90-8-30A Bonding Adhesive	2001 Inc. Bonding Adhesive	Mule-Hide Bonding Adhesive	G200SA Yellow Substrate Adhesive	LC-60 Bonding Adhesive	Royal Edge Bonding Adhesive
EPDM X-23 Low- VOC Bonding Adhesive	-	EPDM X-23 Low VOC Bonding Adhesive	EPDM X-23 Low VOC Bonding Adhesive	EPDM X-23 Low VOC Bonding Adhesive	-
Solvent-Free EPDM Bonding Adhesive	-	-	Solvent-Free EPDM Bonding Adhesive	Solvent-Free EPDM Bonding Adhesive	Royal Edge Solvent-Free EPDM Bonding Adhesive
Aqua Base 120 Bonding Adhesive	-	Aqua Base 120 Bonding Adhesive	Aqua Base 120 Bonding Adhesive	Aqua Base 120 Bonding Adhesive	Royal Edge Water Based Bonding Adhesive
Sure-Weld TPO Bonding Adhesive	-	Mule-Hide TPO-c Bonding Adhesive	VersiWeld TPO Bonding Adhesive	TPO Bonding Adhesive	Royal Edge EPDM/TPO Bonding Adhesive
Low VOC Bonding Adhesive	-	Low VOC Bonding Adhesive	LOW VOC Bonding Adhesive	Low VOC Bonding Adhesive	Royal Edge Low VOC Bonding Adhesive
Low VOC Bonding Adhesive 1168	-	Low VOC Bonding Adhesive 1168	Low VOC Bonding Adhesive 1168	Low VOC Bonding Adhesive 1168	--
Low VOC PVC Bonding Adhesive	-	Low -VOC PVC Bonding Adhesive	Low-VOC PVC Bonding Adhesive	Low-VOC PVC Bonding Adhesive	Re-Flex PVC Low VOC Bonding Adhesive
HydroBond Water-Based Bonding Adhesive	-	HydroBond Water-Based Bonding Adhesive-	HydroBond Water-Based Bonding Adhesive	HydroBond Water-Based Bonding Adhesive	=
CAV-GRIP III Low VOC Adhesive/Primer	-	AeroWeb Adhesive	Cav-Grip 3V Low VOC Adhesive/Primer	Cav-Grip III Low VOC Adhesive/Primer	-

TABLE 1—PRODUCT NAMES (continued)

CARLISLE PRODUCT NAME	KELLY CO./ 2001 INC. PRODUCT NAME	MULE-HIDE PRODUCT NAME	VERSICO PRODUCT NAME	WEATHERBOND PRODUCT NAME	ROOFING PRODUCTS INTERNATIONAL PRODUCT NAME
Cold Applied Adhesive	-	Cold Applied Adhesive	Cold Applied Adhesive	Cold Applied Adhesive	RPI Cold Applied Adhesive
FAST 100 Adhesive	-		DASH 100 Adhesive	-	-
FAST 100-LV Adhesive	-	Helix® 2 Low-Rise Adhesive	DAST Adhesive	DASHAdhesive	FastBond 100 LV Adhesive
Flexible FAST Adhesive	-	Helix® Max Low-Rise Adhesive	Flexible DAST Adhesive	Flexible DASH Adhesive	FastBond Flex Adhesive
OlyBond 500 Adhesive	-	-	OlyBond 500 Adhesive	OlyBond 500 Adhesive	OlyBond 500 Adhesive

TABLE 2—FIRE CLASSIFICATION ASSEMBLIES—ADHERED ROOFING SYSTEMS^{2,5}

SYSTEM NO.	ROOF CLASS	DECK	MAX SLOPE	BARRIER BOARD OR SLIP SHEET	INSULATION ¹	MEMBRANE
1	A	Noncombustible	1/4:12	—	Any of the following insulations, 1-inch min. to 6-inch max. thickness: Carlisle "SecurShield Polyiso", "InsulBase", Hunter Panels "H-Shield" or "H-Shield-CG"	Sure-Weld, Spectro-Weld
2			1/2:12			Sure-Seal FR, Sure-Tough, Sure-White, Sure-Seal FleeceBACK, Sure-Weld HS, Sure-Weld SAT-TPO, Sure-Weld FleeceBACK, Spectro-Weld FleeceBACK, Sure-White FleeceBACK
3			3/4:12			Sure-Flex PVC FleeceBACK, Sure-Flex KEE HP FleeceBACK, Sure-Flex PVC FRS FleeceBACK, Sure-Flex KEE HP FRS FleeceBACK
4			2:12			Sure-Flex PVC, Sure-Flex PVC FRS, Sure-Flex KEE HP
5	A	Noncombustible	3/4:12	—	1/2-inch-thick fiberboard ⁴ , 1/2-inch-thick fiberboard ⁴ or barrier board (see Section 3.6) over 5-inch max Insulfoam EPS ³ , 1/2-inch-thick fiberboard or barrier board (see Section 3.6) over System No. 1 insulations	Sure-White FleeceBACK
6			1:12			Sure-Seal FR, Sure-Tough
7			1 1/2:12			Sure-White, Sure-Seal FleeceBACK, Sure-Weld, Spectro-Weld, Sure-Weld HS, Sure-Weld SAT-TPO, Sure-Weld FleeceBACK, Spectro-Weld FleeceBACK, Sure-Flex PVC, Sure-Flex PVC FRS, Sure-Flex KEE HP, Sure-Flex PVC FleeceBACK, Sure-Flex KEE HP FleeceBACK, Sure-Flex PVC FRS FleeceBACK, Sure-Flex KEE HP FRS FleeceBACK
8	A	Noncombustible or Combustible - min. 15/32-inch-thick plywood or min. 7/16-inch-thick OSB.	3/4:12	1/4-inch thick "DensDeck Prime" or 1/4-inch thick "SECUROCK Gypsum Fiber Roof Board"	—	Sure-White FleeceBACK
9			1 1/2:12			Sure-White, Sure-Seal FleeceBACK
10			3:12			Sure-Tough, Sure-Weld, Spectro-Weld, Sure-Weld FleeceBACK, Spectro-Weld FleeceBACK
11			4:12			Sure-Weld HS, Sure-Weld SAT-TPO
12			Unlimited			Sure-Seal FR, Sure-Flex PVC, Sure-Flex PVC FRS, Sure-Flex KEE HP
13			3:12			Sure-Flex PVC FleeceBACK, Sure-Flex KEE HP FleeceBACK, Sure-Flex PVC FRS FleeceBACK, Sure-Flex KEE HP FRS FleeceBack

TABLE 2—FIRE CLASSIFICATION ASSEMBLIES—ADHERED ROOFING SYSTEMS^{2,5} (continued)

SYSTEM NO.	ROOF CLASS	DECK	MAX SLOPE	BARRIER BOARD OR SLIP SHEET	INSULATION ¹	MEMBRANE
14	A	Combustible min. ¹⁵ / ₃₂ -inch-thick plywood or min. ⁷ / ₁₆ -inch-thick OSB.	¹ / ₄ :12	Barrier board (see Section 3.6) or Slip sheet: 2 layers (see Section 3.7)	Any of the following insulations, 1-inch min. to 6-inch max. thickness: Carlisle "SecurShield Polyiso", "InsulBase", Hunter Panels "H-Shield" or "H-Shield-CG"	Sure-Weld, Spectro-Weld
15			¹ / ₂ :12			Sure-Seal FR, Sure-Tough, Sure-White, Sure-Seal FleeceBACK, Sure-Weld HS, Sure-Weld SAT-TPO, Sure-Weld FleeceBACK, Spectro-Weld FleeceBACK, Sure-White FleeceBACK
16			³ / ₄ :12			Sure-Flex PVC FleeceBACK, Sure-Flex KEE HP FleeceBACK, Sure-Flex PVC FRS FleeceBACK, Sure-Flex KEE FRS FleeceBACK
17			2:12			Sure-Flex PVC, Sure-Flex PVC FRS, Sure-Flex KEE HP
18	C	Noncombustible or Combustible min. ¹⁵ / ₃₂ -inch-thick plywood or min. ⁷ / ₁₆ -inch-thick OSB.	Unlimited	—	Any of the following insulations, min. 1-inch thickness: Carlisle "InsulBase" or Hunter Panels "H-Shield"	EPDM, PVC and TPO Membranes
19	A	Combustible	¹ / ₂ :12	—	Single layer of minimum 3.0" or double layer of minimum 1.5" Carlisle "SecurShield Polyiso" or Hunter Panels "H-Shield-CG"	EPDM, PVC, and TPO Membranes
20	B	Combustible	¹ / ₂ :12	—	Single layer of minimum 1.9" Carlisle "SecurShield Polyiso" or Hunter Panels "H-Shield-CG"	EPDM, PVC, and TPO Membranes

For SI: 1 inch = 25.4 mm.

¹All foam plastic insulation must be UL-classified foamed plastic for roofing systems, and must be limited to the maximum thickness in accordance with Section 5.4 of this report or the maximum thickness in accordance with this table, whichever is less.

²See Section 3.10 for adhesive application rate.

³UL Classified EPS may be installed below min. 1-inch-thick Carlisle or Hunter Panels polyisocyanurate insulations (max slope 1:12) or below min. ¹/₂-inch-thick Carlisle SecurShield HD or Hunter Panels H-Shield HD (max slope 2:12) on noncombustible decks.

⁴Carlisle SecurShield HD or Hunter Panels H-Shield HD may replace fiberboard and may be used as a coverboard over any insulation. When these two boards are used directly below the Sure-Weld membrane, the slope is limited to max. ¹/₂:12.

⁵When these systems are used for reroofing or recovering, installation must be in accordance with Sections 4.2.2 and 5.7 of this report, and 2018 and 2015 IBC Section 1511 [2012 and 2009 IBC Section 1510], 2018 and 2015 IRC Section R908 [2012 and 2009 IRC Section R907], as applicable.

TABLE 3—FIRE CLASSIFICATION ASSEMBLIES—MECHANICALLY FASTENED ROOFING SYSTEMS⁴

SYSTEM NO.	ROOF CLASS	DECK	MAX. SLOPE	BARRIER BOARD OR SLIP SHEET	INSULATION ¹	MEMBRANE/MAX. ROOF SLOPE
1	A	Noncombustible	1/2:12	—	Any of the following insulations, 1-inch min. to 6-inch max. thickness: Carlisle “SecurShield Polyiso” or “InsulBase”, Hunter Panels “H-Shield” or “H-Shield-CG”	Sure-Tough, Sure-Weld, Spectro-Weld
2			1 1/2:12			Sure-Weld HS
3			3/4:12			Sure-Tough FR
4			2 1/2:12			Sure-Flex PVC, Sure-Flex KEE HP
5	A	Noncombustible	1:12	—	1/2-inch-thick fiberboard ³ , 1/2-inch-thick fiberboard ⁴ or barrier board (see Section 3.6) over 5-inch max Insulfoam EPS ² , 1/2-inch-thick fiberboard or barrier board (see Section 3.6) over System No. 1 insulations	Sure-Tough, Sure-Flex
6			1 1/2:12			Sure-Weld, Spectro-Weld, Sure-Weld HS
7			2 1/2:12			Sure-Tough FR
8	A	Noncombustible	1/2:12	—	To 5-inch max: Insulfoam SP	Sure-Weld, Spectro-Weld, Sure-Weld HS, Sure-Flex, Sure-Flex KEE HP
9	A	Noncombustible or Combustible min. 15/32-inch-thick plywood or min. 7/16-inch-thick OSB.	3:12	Barrier board (see Section 3.6)	—	Sure-Tough, Sure-Weld, Spectro-Weld
10			3 1/2:12			Sure-Tough FR
11			Unlimited			Sure-Weld HS, Sure-Flex, Sure-Flex KEE HP
12	A	Combustible min. 15/32-inch-thick plywood or min. 7/16-inch-thick OSB.	1/2:12	Barrier board (see Section 3.6) or Slip sheet: 2 layers, (see Section 3.7)	Any of the following insulations, 1-inch min. to 6-inch max. thickness: Carlisle “SecurShield Polyiso” or “InsulBase”, Hunter Panels “H-Shield” or “H-Shield-CG”	Sure-Tough, Sure-Weld, Spectro-Weld
13			1 1/2:12			Sure-Weld HS
14			3/4:12			Sure-Tough FR
15			2 1/2:12			Sure-Flex PVC, Sure-Flex KEE HP
16	A	Combustible min. 15/32-inch-thick plywood or min. 7/16-inch-thick OSB	1:12	Slip sheet, 2 layers (see Section 3.7)	—	Sure-Tough
17			1 1/2:12			Sure-Tough FR, Sure Weld, Spectro-Weld, Sure-Weld HS, Sure-Flex, Sure-Flex KEE HP
18	B	Combustible min. 15/32-inch-thick plywood or min. 7/16-inch-thick OSB.	1 1/2:12	Slip sheet, 1 layer (see Section 3.7)	—	Sure-Tough, Sure-Tough FR, Sure-Weld, Spectro-Weld, Sure-Weld HS, Sure-Flex, Sure-Flex KEE HP
19	C	Combustible min 15/32-inch-thick plywood or min. 7/16-inch-thick OSB.	Unlimited	—	Any of the following insulations, 1-inch min. thickness: Carlisle “SecurShield Polyiso” or “InsulBase”, Hunter Panels “H-Shield” or H-Shield CG”	EPDM, PVC and TPO Membranes
20	A	Combustible	1/2:12	—	Single layer of minimum 3-inch or double layer of minimum 1.5-inch Carlisle “SecurShield Polyiso” or Hunter Panels “H-Shield-CG”	EPDM, PVC, and TPO Membranes
21	B	Combustible	1/2:12	—	Single layer of minimum 1.9-inch Carlisle “SecurShield Polyiso” or Hunter Panels “H-Shield-CG” or single layer of an inverted G3 cap sheet.	EPDM, PVC, and TPO Membranes

For SI: 1 inch = 25.4 mm.

¹All foam plastic insulation must be UL-classified foamed plastic for roofing systems, and must be limited to the maximum thickness in accordance with Section 5.4 of this report or the maximum thickness in accordance with this table, whichever is less.

²UL Classified EPS may be installed below min. 1-inch-thick Carlisle or Hunter Panels polyisocyanurate insulations (max slope 1:12) or below min. 1/2-inch-thick Carlisle SecurShield HD or Hunter Panels H-Shield HD (max slope 2:12) on noncombustible decks.

³Carlisle SecurShield HD or Hunter Panels H-Shield HD may replace fiberboard and may be used as a coverboard over any insulation. When these two boards are used directly below the Sure-Weld membrane, the slope is limited to 1/2:12.

⁴When these systems are used for reroofing or recovering, installation must be in accordance with Sections 4.2.2 and 5.7 of this report, and 2018 and 2015 IBC Section 1511 [2012 and 2009 IBC Section 1510], 2018 and 2015 IRC Section R908 [2012 and 2009 IRC Section R907], as applicable.

TABLE 4—WIND RESISTANCE—MECHANICALLY FASTENED ASSEMBLIES^{4,7}

SYSTEM NO.	MAXIMUM ALLOWABLE WIND UPLIFT (psf)	DECK ³	INSULATION ⁵	MEMBRANE	MEMBRANE FASTENING	MAXIMUM FASTENER SPACING (inches)	MAXIMUM FASTENER ROW SPACING ⁸
1	45	Noncombustible	Foam plastic insulation ^{1,2} , 1/2-inch-thick fiberboard ⁶ or barrier board (See Sect. 3.6)	Sure-Tough	HP-X Fastener & Metal Fastening Bar	12	6 ft 6 inches
2	75	Noncombustible	Same as System No. 1	Sure-Tough	HP-X Fastener & Metal Fastening Bar	6	6 ft 6 inches
3	52	Noncombustible	Same as System No. 1	Sure-Tough	HP Fastener & Polymer Seam Plate	6	9 ft 6 inches
4	45	Noncombustible	Same as System No. 1	Sure-Tough	Sure-Tite Fastener & ST Fastening Bar	12	9 ft 6 inches
5	30	Noncombustible	Same as System No. 1	Sure-Tough (75 mil)	HP Fastener & Polymer Seam Plate	12	9 ft 6 inches
6	60	Noncombustible	Same as System No. 1	Sure-Tough (75 mil)	HP Fastener & Polymer Seam Plate	6	9 ft 6 inches
7	45	Noncombustible	Same as System No. 1	Sure-Weld or Spectro-Weld	HP-X or HP-Xtra Fasteners with Piranha or Piranha Xtra Plates	12	7 ft 6 inches
8	45	Noncombustible	Same as System No. 1	Sure-Weld or Spectro-Weld	HP-Xtra Fasteners with Piranha Xtra Plates	12	9 ft 6 inches
9	60	Noncombustible	Same as System No. 1	Sure-Weld or Spectro-Weld	HP-X or HP-Xtra Fasteners with Piranha or Piranha Xtra Plates	6	9 ft 6 inches
10	67	Noncombustible	Same as System No. 1	Sure-Weld or Spectro-Weld	HP-X or HP-Xtra Fasteners with Piranha or Piranha Xtra Plates	6	7 ft 6 inches
11	30	Noncombustible	Same as System No. 1	Sure-Weld or Spectro-Weld	HP-X or HP-Xtra Fasteners with Piranha or Piranha Xtra Plates	12	11 ft 6 inches
12	60	Noncombustible	Same as System No. 1	Sure-Weld or Spectro-Weld	HP-X or HP-Xtra Fasteners with Piranha or Piranha Xtra Plates	6	11 ft 6 inches
13	53	Noncombustible	Same as System No. 1	Sure-Flex PVC or Sure-Flex KEE HP	HP-X Fasteners with Piranha Plates	6	6 ft 4 inches
14	83	Noncombustible	Same as System No. 1	Sure-Flex PVC or Sure-Flex KEE HP	HP-X Fasteners with Piranha Plates	6	2 ft 11 inches
15	30	Noncombustible	Same as System No. 1	Sure-Flex PVC or Sure-Flex KEE HP	HP-X or HP-Xtra Fasteners with Piranha or Piranha Xtra Plates	18	6 ft 4 inches
16	45	Noncombustible	Same as System No. 1	Sure-Flex PVC or Sure-Flex KEE HP	HP-X or HP-Xtra Fasteners with Piranha or Piranha Xtra Plates	12	6 ft 4 inches
17	53	Noncombustible	Same as System No. 1	Sure-Flex PVC or Sure-Flex KEE HP	HP-X Fasteners with Piranha Plates	12	2 ft 11 inches
18	60	Noncombustible	Same as System No. 1	Sure-Flex PVC or Sure-Flex KEE HP	HP-X or HP-Xtra Fasteners with Piranha Plates	6	9 ft 7 inches
19	45	Noncombustible	Same as System No. 1	Sure-Weld	HP-X Fasteners with OMG RhinoBond Plates	1 per 5.3 ft ²	N/A
20	60	Noncombustible	Same as System No. 1	Sure-Weld	HP-X Fasteners with OMG RhinoBond Plates	1 per 4 ft ²	N/A

For SI: 1 inch = 25.4 mm; 1 ft = 0.305 m; 1 psf = 47.88 Pa.

¹Foam plastic insulation must be any of the following (1-inch min. to 6-inch max. thickness): Carlisle "SecurShield Polyiso", "InsulBase" Hunter Panels "H-Shield" or Hunter Panels "H-Shield- CG".

²All foam plastic insulation must be UL-classified foamed plastic for roofing systems, and must be limited to the maximum thickness in accordance with Section 5.4 of this report or the maximum thickness in accordance with this table, whichever is less.

³Steel deck must be minimum No. 22 gage galvanized steel [base-metal thickness 0.030 inch (0.76 mm)]. Concrete must have a minimum compressive strength (f'_c) of 2500 psi. See Section 5.6 of this report.

⁴For existing metal roofing, the assemblies listed must be installed by fastening through the roofing and into structural members (purlins, angle iron, beams, etc.) capable of resisting all expected loads. The maximum allowable wind uplift (field) pressures are shown in Column 2.

⁵UL Classified EPS may be installed below min. 1-inch-thick Carlisle or Hunter Panels polyisocyanurate insulations (max slope 1:12) or below min. 1/2-inch-thick Carlisle SecurShield HD or Hunter Panels H-Shield HD (max slope 2:12) on noncombustible decks.

⁶Carlisle SecurShield HD or Hunter Panels H-Shield HD may replace fiberboard and may be used as a coverboard over any insulation. When these two boards are used directly below the Sure-Weld membrane, the slope is limited to 1/2:12.

⁷When these systems are used for reroofing or recovering, installation must be in accordance with Sections 4.2.2 and 5.7 of this report, and 2018 and 2015 IBC Section 1511 [2012 and 2009 IBC Section 1510], 2018 and 2015 IRC Section R908 [2012 and 2009 IRC Section R907], as applicable.

⁸Fastener row spaces shown are for field of roof only. See Section 4.3 for recognized fascia systems for mechanically fastened roof assemblies. Distance between the edge of the roof and the first row of fasteners must be determined accordingly.

TABLE 5—WIND RESISTANCE—ADHERED ASSEMBLIES^{5,6}

SYSTEM NO.	ALLOWABLE WIND UPLIFT (FIELD) (psf)	DECK ²	INSULATION / MIN. THICKNESS ^{1,3}	INSULATION FASTENING RATE	MEMBRANE TYPE
1	45	Combustible or Noncombustible	1/2 inch fiberboard ⁴ , 15/32 inch OSB, or 1/4-inch thick "DensDeck Prime" or 1/4-inch thick "SECUROCK Gypsum Fiber Roof Board"	1 per 2 ft ²	EPDM, PVC and TPO Membranes
2	45	Combustible or Noncombustible	Carlisle "InsulBase" or "SecurShield Polyiso"; Hunter Panels "H-Shield" or "H-Shield-CG" / 1.4 inch with 1/2-inch SECUROCK coverboard (optional)	1 per 3.2 ft ²	EPDM, PVC and TPO Membranes
3	45	Combustible or Noncombustible	Carlisle "InsulBase" or "SecurShield Polyiso"; Hunter Panels "H-Shield" or "H-Shield-CG" / 2.0 inch with 5/8-inch SECUROCK coverboard (optional)	1 per 4 ft ²	EPDM, PVC and TPO Membranes
4	68	Combustible or Noncombustible	Carlisle "InsulBase" or "SecurShield Polyiso"; Hunter Panels "H-Shield" or "H-Shield-CG" / 1.0 inch	FAST Adhesive	FleeceBACK Membranes
5	75	Combustible or Noncombustible	Carlisle "InsulBase" or "SecurShield Polyiso"; Hunter Panels "H-Shield" or "H-Shield-CG" / 2.0 inch with 1/2-inch SECUROCK coverboard (optional)	1 per 1.6 ft ²	EPDM, PVC and TPO Membranes
6	113	Combustible or Noncombustible	Carlisle "SecurShield" or "H-Shield CG" / 2.0 inch	1 per 1ft ²	PVC Membranes
7	120	Combustible or Noncombustible	Carlisle "InsulBase" or "SecurShield Polyiso"; Hunter Panels "H-Shield" or "H-Shield-CG" / 2.0 inch	1 per 1 ft ²	TPO Membranes; EPDM membranes (with noncombustible deck only)
8	128	Combustible or Noncombustible	Carlisle "InsulBase" or "SecurShield Polyiso"; Hunter Panels "H-Shield" or "H-Shield-CG" / 2.0 inch with 1/2-inch SECUROCK coverboard (optional)	1 per 1 ft ²	EPDM and TPO Membranes
9	135	Combustible or Noncombustible	Carlisle "InsulBase" or "SecurShield Polyiso"; Hunter Panels "H-Shield" or "H-Shield-CG" / 2.0 inch with 1/2-inch SECUROCK coverboard (optional)	1 per 1 ft ²	FleeceBACK Membranes
10	143	Combustible or Noncombustible	1/2 inch DensDeck Prime	1 per 1 ft ²	FleeceBACK Membranes

For S_I: 1 inch = 25.4 mm; 1 ft = 0.305 m; 1 psf = 47.88 Pa

¹All foam plastic insulation must be UL-classified foamed plastic for roofing systems, and must be limited to the maximum thickness in accordance with Section 5.4 of this report or the maximum thickness in accordance with this table, whichever is less.

²Steel deck must be minimum No. 22 gage galvanized steel [base-metal thickness 0.030 inch (0.76 mm)]. Concrete must have a minimum compressive strength (f_c) of 2500 psi. See Section 5.6 of this report.

³UL Classified EPS may be installed below min. 1-inch-thick Carlisle or Hunter Panels polyisocyanurate insulations (max slope 1:12) or below min. 1/2-inch-thick Carlisle SecurShield HD or Hunter Panels H-Shield HD (max slope 2:12) on noncombustible decks.

⁴Carlisle SecurShield HD or Hunter Panels H-Shield HD may replace fiberboard and may be used as a coverboard over any insulation. When these two boards are used directly below the Sure-Weld membrane, the slope is limited to 1/2:12.

⁵When application is over existing roofs, documentation of the wind-uplift resistance of the composite roof construction must be submitted to the code official for approval at the time of permit application. For reroofing or recovering, installation must be in accordance with 2018 and 2015 IBC Section 1511 [2012 and 2009 IBC Section 1510], 2018 and 2015 IRC Section R908 [2012 and 2009 IRC Section R907], as applicable.

⁶See Section 3.10 for adhesive application rate.

DIVISION: 07 00 00—THERMAL AND MOISTURE PROTECTION
Section: 07 53 23—Ethylene-Propylene-Diene-Monomer Roofing
Section: 07 54 19—Polyvinyl-Chloride Roofing
Section: 07 54 23—Thermoplastic-Polyolefin Roofing

REPORT HOLDER:

CARLISLE SYNTEC SYSTEMS

EVALUATION SUBJECT:

CARLISLE EPDM, PVC AND TPO SINGLE-PLY ROOFING MEMBRANES

1.0 REPORT PURPOSE AND SCOPE

Purpose:

The purpose of this evaluation report supplement is to indicate that Carlisle EPDM, PVC and TPO Single-ply Roofing Membranes, described in ICC-ES evaluation report ESR-1463, have also been evaluated for compliance with the codes noted below as adopted by the Los Angeles Department of Building and Safety (LADBS).

Applicable code editions:

- 2017 *City of Los Angeles Building Code* (LABC)
- 2017 *City of Los Angeles Residential Code* (LARC)

2.0 CONCLUSIONS

The Carlisle EPDM, PVC and TPO Single-ply Roofing Membranes, described in Sections 2.0 through 7.0 of the evaluation report [ESR-1463](#), comply with the LABC Chapters 7A and 15, the LARC Section R337 and LARC Chapter 9, and are subjected to the conditions of use described in this supplement.

3.0 CONDITIONS OF USE

The Carlisle EPDM, PVC and TPO Single-ply Roofing Membranes, described in this evaluation report must comply with all of the following conditions:

- All applicable sections in the evaluation report [ESR-1463](#).
- The design, installation, conditions of use and identification are in accordance with the 2015 *International Building Code*® (2015 IBC) and 2015 *International Residential Code*® (2015 IRC) provisions noted in the evaluation report [ESR-1463](#).
- The design, installation and inspection are in accordance with additional requirements of LABC Chapters 16 and 17, or LARC Chapter 3, as applicable.
- The Carlisle EPDM, PVC and TPO Single-ply Roofing Membranes must not be installed over existing wood shakes or wood shingles in accordance with LABC Section 1511.
- The installation of the Carlisle EPDM, PVC and TPO Single-ply Roofing Membranes must comply with City of Los Angeles Information Bulletin P/BC 2014-16, "Dwellings in High Wind Velocity Areas (HWA)".
- Reroofing applications must comply with Sections 4.2.2, 4.3.2 and 5.7 of the evaluation report [ESR-1463](#) and LABC Section 1511 or LARC Section R908, as applicable. Where spaced sheathing exists, a minimum of 15/32-inch-thick (11.9 mm) plywood shall be installed prior to roofing installations.

- Where moderate or heavy foot traffic occurs for maintenance of equipment, the roof covering shall be adequately protected.
- The Building Inspector shall be notified 24 hours in advance prior to installation of the roof membranes.
- The Carlisle EPDM, PVC and TPO Single-ply Roofing Membranes may be used in the construction of new buildings located in any Fire Hazard Severity Zone within a State Responsibility Areas or any Wildland-Urban Interface Fire Area, provided installation is in accordance with the 2015 *International Building Code*® (IBC) provisions noted in the evaluation report and the additional requirements of Sections 701A.3 and 705A of the LABC.
- The Carlisle EPDM, PVC and TPO Single-ply Roofing Membranes may be used in the construction of new buildings located in any Fire Hazard Severity Zone within a State Responsibility Areas or any Wildland-Urban Interface Fire Area, provided installation is in accordance with the 2015 *International Residential Code*® (IRC) provisions noted in the evaluation report and the additional requirements of Sections R337.3.1 and R337.5 of the LARC.

This supplement expires concurrently with the evaluation report, reissued October 2020.

DIVISION: 07 00 00—THERMAL AND MOISTURE PROTECTION
Section: 07 53 23—Ethylene-Propylene-Diene-Monomer Roofing
Section: 07 54 19—Polyvinyl-Chloride Roofing
Section: 07 54 23—Thermoplastic-Polyolefin Roofing

REPORT HOLDER:

CARLISLE SYNTEC SYSTEMS, A DIVISION OF CARLISLE CONSTRUCTION MATERIALS, LLC

EVALUATION SUBJECT:

CARLISLE EPDM, PVC AND TPO SINGLE-PLY ROOFING MEMBRANES

1.0 REPORT PURPOSE AND SCOPE

Purpose:

The purpose of this evaluation report supplement is to indicate that the Carlisle EPDM, PVC and TPO single-ply roofing membranes, described in ICC-ES evaluation report ESR-1463, have also been evaluated for compliance with the codes noted below.

Applicable code editions:

- 2019 *California Building Code* (CBC)

For evaluation of applicable chapters adopted by the California Office of Statewide Health Planning and Development (OSHPD) and Division of State Architect (DSA), see Sections 2.1.1 and 2.1.2 below.

- 2019 *California Residential Code* (CRC)

2.0 CONCLUSIONS

2.1 CBC:

The Carlisle EPDM, PVC and TPO single-ply roofing membranes, described in Sections 2.0 through 7.0 of the evaluation report ESR-1463, comply with CBC Chapter 15, provided the design and installation are in accordance with the 2018 *International Building Code*® (IBC) provisions noted in the evaluation report and the additional requirements of CBC Chapter 15, as applicable.

2.1.1 OSHPD: The applicable OSHPD Sections of the CBC are beyond the scope of this supplement.

2.1.2 DSA: The applicable DSA Sections of the CBC are beyond the scope of this supplement.

2.2 CRC:

The Carlisle EPDM, PVC and TPO single-ply roofing membranes, described in Sections 2.0 through 7.0 of the evaluation report ESR-1463, comply with CRC Chapter 95, provided the design and installation are in accordance with the 2018 *International Residential Code*® (IRC) provisions noted in the evaluation report and the additional requirements of CRC Chapter 9, as applicable.

This supplement expires concurrently with the evaluation report, reissued October 2020.

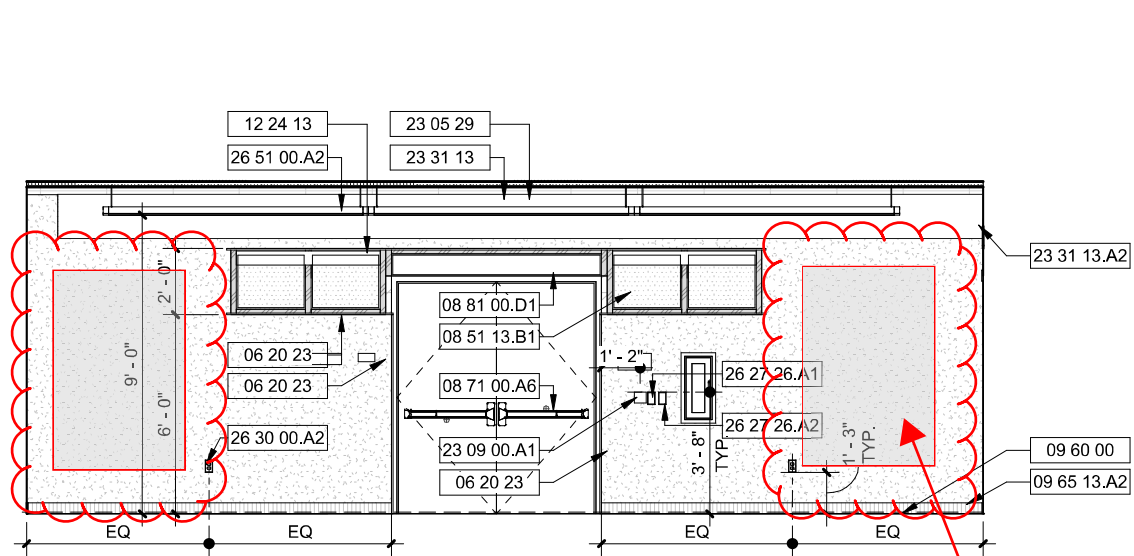

12 M3-1 ASSEMBLY ROOM - SOUTH
1/4" = 1'-0"

4x6 TACKBOARD
TYP.

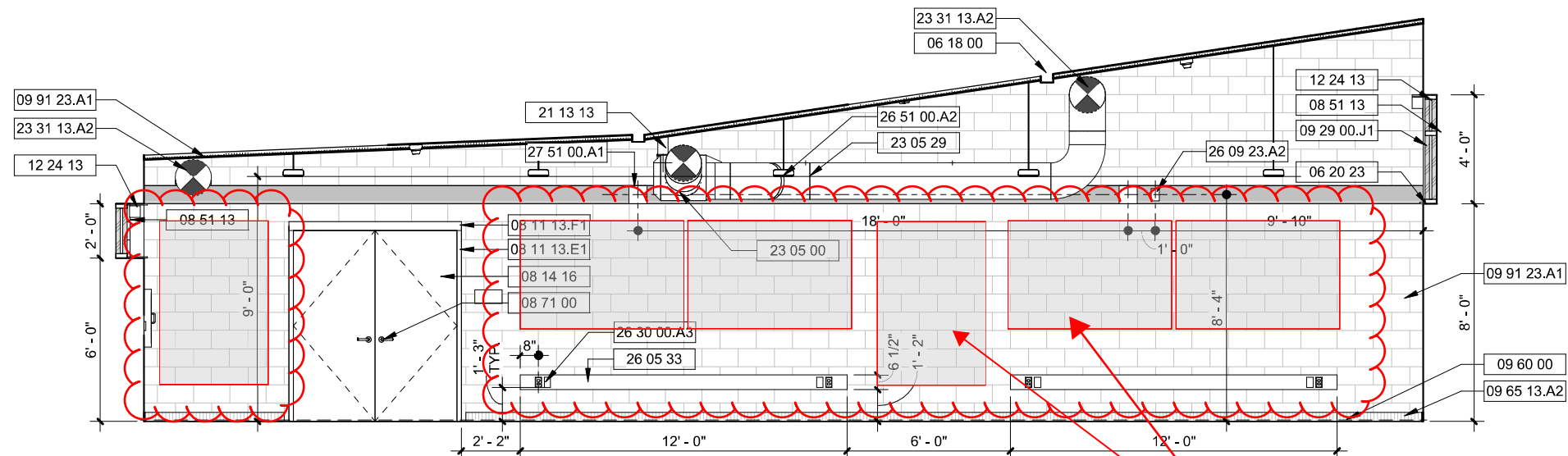

11 M3-1 ASSEMBLY ROOM - WEST
1/4" = 1'-0"

4x6 TACKBOARD
TYP.

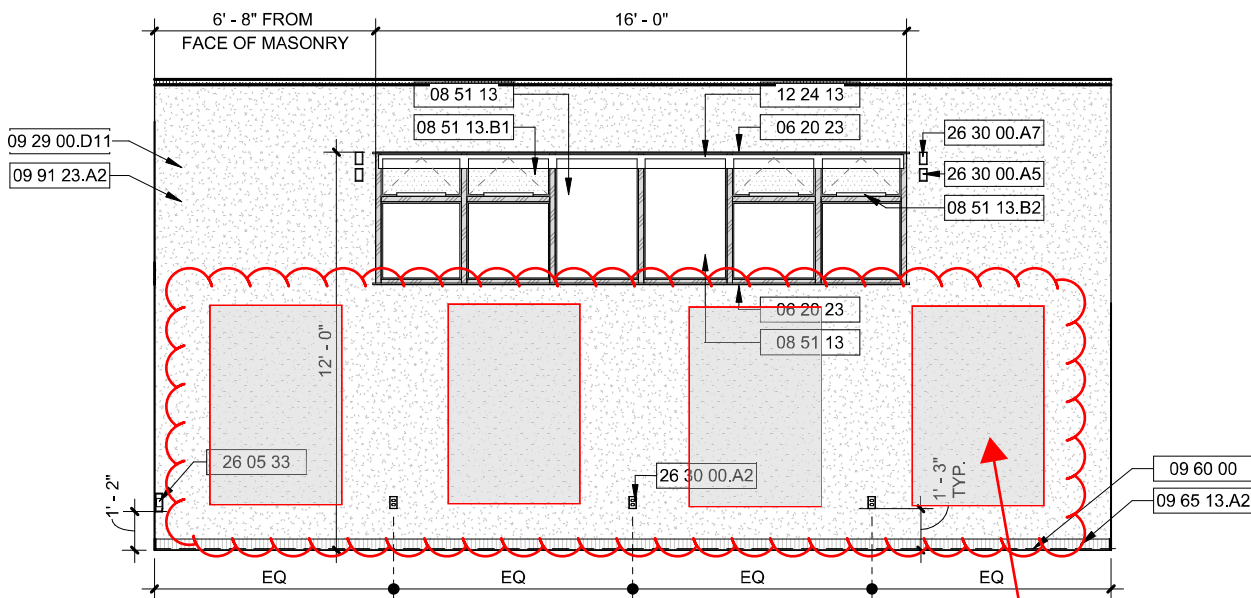

10 M3-1 ASSEMBLY ROOM - NORTH
1/4" = 1'-0"

4x6 TACKBOARD
TYP.

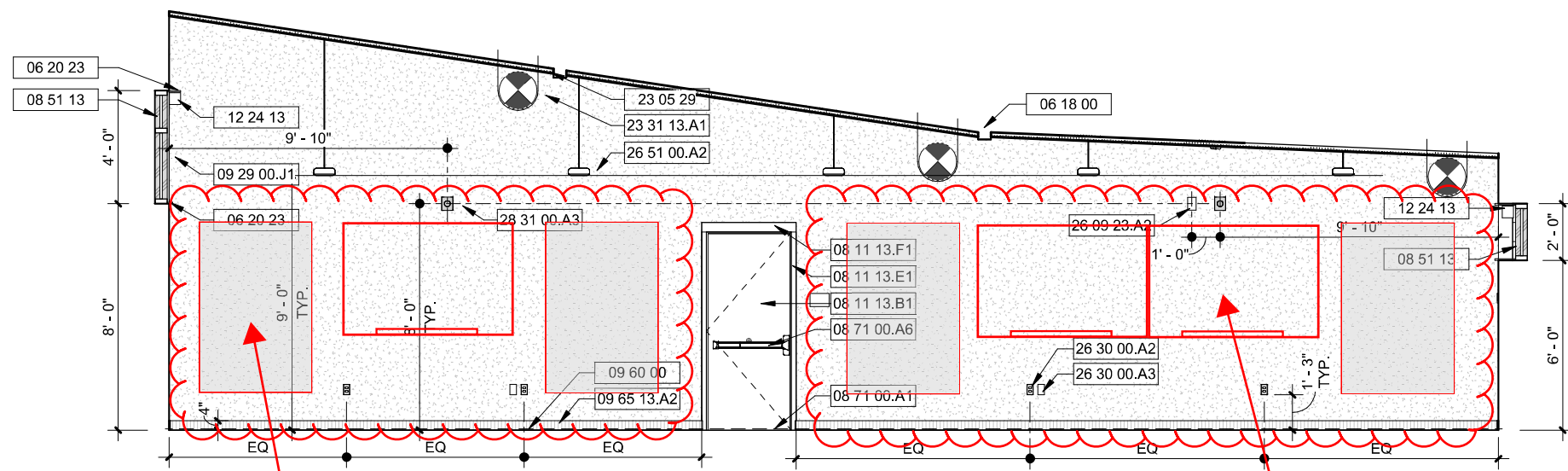

9 M3-1 ASSEMBLY ROOM - EAST
1/4" = 1'-0"

4x8 MARKER
BOARD WITH TRAY
TYP.

DAVY ARCHITECTURE
SBHS MAKERS SPACE _ BLDG M3
ADDITIONAL MARKER BOARDS AND TACK BOARDS
7.15.21